



Universiteit  
Leiden  
The Netherlands

## **Portfolio optimization: Beyond Markowitz**

Engels, M.G.

### **Citation**

Engels, M. G. (2004). *Portfolio optimization: Beyond Markowitz*.

Version: Not Applicable (or Unknown)

License: [License to inclusion and publication of a Bachelor or Master thesis in the Leiden University Student Repository](#)

Downloaded from: <https://hdl.handle.net/1887/3597580>

**Note:** To cite this publication please use the final published version (if applicable).

# Portfolio Optimization: Beyond Markowitz

Master's Thesis by  
Marnix Engels

January 13, 2004





---

# Preface

---

This thesis is written to get my master's title for my studies mathematics at Leiden University, the Netherlands. My graduation project is done during an internship at Rabobank International, Utrecht, where I have been from May till December 2003.

At the beginning of the internship, it was quite a shift to start thinking in banking terms, where I was used to reason in a pure mathematical context. But as with most things in life, with a lot of curiosity, patience and perseverance a nice result can be made. I have learned a lot during the internship. It was surprising for me how much of the four-year mathematical studies I was able to use in the banking world. Optimizing, statistics, linear algebra, second order cone programming and the use of MATLAB are just a few subjects I used during the last seven months.

My special thanks goes to Mâcé Mesters for guiding me throughout the internship and for teaching me there are always more articles to read. I also like to thank my roommates Walter Foppen (for playing DJ Foppen, Walter de gekste!) and Harmenjan Sijtsma (for getting tea all the time) and teammate Martijn Derix (for installing a lot of illegal software, essential for writing this thesis, on my computer). For their helpful comments I thank Freddy van Dijk, Erik van Raaij, Roger Lord, Natalia Borovykh, Adriaan Kukler, Marion Segeren, Erwin Sandee, Rik Albrecht and Sacha van Weeren. From Leiden University, I was supervised by prof. dr. L.C.M. Kallenberg, to whom I am very grateful. To conclude, thanks to my parents for supporting me throughout my studies, and I say hullo to Heidi.

Marnix Engels  
Leiden, January 13, 2004



---

# Contents

---

<b>Preface</b>	<b>iii</b>
<b>List of figures</b>	<b>viii</b>
<b>List of tables</b>	<b>xi</b>
<b>List of symbols</b>	<b>xiii</b>
<b>1 Introduction</b>	<b>1</b>
<b>2 The portfolio theory of Markowitz</b>	<b>5</b>
2.1 Efficient frontier . . . . .	5
2.2 Minimum variance portfolio . . . . .	8
2.3 Tangency portfolio . . . . .	9
2.4 Optimal portfolio . . . . .	11
2.5 Adding a risk-free asset . . . . .	14
2.5.1 Capital market line & market portfolio . . . . .	14
2.5.2 Optimal portfolio . . . . .	16
2.6 Sensitivity analysis . . . . .	18
2.7 Example . . . . .	20
2.7.1 Data . . . . .	20
2.7.2 Calculations . . . . .	23
2.8 References . . . . .	26
<b>3 Another approach for risk: Safety first</b>	<b>27</b>
3.1 Safety first models . . . . .	27
3.2 Telsers criterion . . . . .	28
3.2.1 Formulation . . . . .	28
3.2.2 Intuitive solution . . . . .	29
3.2.3 Analytical solution . . . . .	30

3.3	With risk-free asset . . . . .	30
3.3.1	Intuitive solution . . . . .	30
3.3.2	Analytical solution . . . . .	32
3.4	Example . . . . .	32
3.5	References . . . . .	35
<b>4</b>	<b>Elliptical distributions</b>	<b>37</b>
4.1	Introduction . . . . .	37
4.2	Some examples of elliptical distributions . . . . .	39
4.2.1	Normal family . . . . .	39
4.2.2	Student-t family . . . . .	39
4.2.3	Laplace family . . . . .	40
4.2.4	Logistic family . . . . .	41
4.2.5	Differences and similarities . . . . .	42
4.3	Mean-variance analysis . . . . .	44
4.4	Telser and elliptically distributed returns . . . . .	46
4.5	Example . . . . .	48
4.6	References . . . . .	51
<b>5</b>	<b>Value at Risk based optimization</b>	<b>53</b>
5.1	VaR efficient frontier . . . . .	53
5.2	Adding the risk-free asset . . . . .	58
5.3	Optimal portfolios . . . . .	59
5.3.1	Minimum Value at Risk portfolio . . . . .	59
5.3.2	Tangency VaR portfolio . . . . .	60
5.3.3	Telser . . . . .	61
5.3.4	Telser with risk-free asset . . . . .	63
5.4	Example . . . . .	64
5.5	References . . . . .	70
<b>6</b>	<b>Maximizing the performance measures EVA and RAROC</b>	<b>73</b>
6.1	EVA and RAROC . . . . .	73
6.2	New Telser models . . . . .	74
6.2.1	EVA with allocated capital . . . . .	74
6.2.2	EVA with consumed capital . . . . .	75
6.2.3	RAROC with allocated capital . . . . .	79
6.2.4	RAROC with consumed capital . . . . .	79
6.2.5	Comparison EVA-RAROC . . . . .	80
6.3	Models with risk-free asset . . . . .	82
6.3.1	EVA . . . . .	82
6.3.2	RAROC . . . . .	83
6.4	Example . . . . .	84
6.5	References . . . . .	85
<b>7</b>	<b>Modeling uncertainty of input parameters</b>	<b>87</b>
7.1	Overview . . . . .	87
7.2	Uncertainty sets . . . . .	88
7.3	Second order cone programming . . . . .	88
7.4	Portfolio optimization and SOCP . . . . .	90
7.4.1	Markowitz . . . . .	90

7.4.2	Telser . . . . .	91
7.5	Portfolio optimization with uncertainty . . . . .	91
7.5.1	Markowitz . . . . .	91
7.5.2	Telser . . . . .	93
7.6	A more realistic approach . . . . .	94
7.6.1	Markowitz . . . . .	95
7.6.2	Telser . . . . .	95
7.7	Example . . . . .	96
7.7.1	Uncertainty sets . . . . .	96
7.7.2	Calculations . . . . .	98
7.8	References . . . . .	100
<b>8</b>	<b>Conclusion</b> . . . . .	<b>103</b>
8.1	Concluding example . . . . .	103
8.2	Future research . . . . .	105
	<b>Appendices</b> . . . . .	<b>106</b>
<b>A</b>	<b>Some large calculations</b> . . . . .	<b>107</b>
A.1	The market portfolio . . . . .	107
A.2	The Telser portfolio . . . . .	109
A.3	The Value at Risk efficient frontier . . . . .	109
<b>B</b>	<b>Telser portfolio analytical</b> . . . . .	<b>111</b>
B.1	No risk-free asset . . . . .	111
B.2	With risk-free asset . . . . .	114
<b>C</b>	<b>MATLAB programs</b> . . . . .	<b>117</b>
C.1	robustmarkowitz.m . . . . .	117
C.2	robusttelser.m . . . . .	118
C.3	robustmarkowitz2.m . . . . .	119
C.4	robusttelser2.m . . . . .	119





---

# List of Figures

---

2.1	The efficient frontier . . . . .	7
2.2	The minimum variance portfolio . . . . .	9
2.3	The tangency portfolio . . . . .	10
2.4	The optimal portfolio . . . . .	12
2.5	The market portfolio and Capital Market Line . . . . .	14
2.6	The optimal portfolio with risk-free asset . . . . .	17
2.7	Overview of indexed returns of seven members of Dutch AEX-index	22
2.8	Graphical view of the portfolios of the example . . . . .	26
3.1	The feasible area $A$ and the optimal Telser point . . . . .	29
3.2	The optimal Telser portfolio with risk-free asset . . . . .	31
3.3	Graphical view of the Telser portfolio of this example . . . . .	34
4.1	Marginal and bivariate standard normal density function . . . . .	40
4.2	Marginal and bivariate student-t density functions . . . . .	41
4.3	Marginal and bivariate Laplace density functions . . . . .	42
4.4	Marginal and bivariate Logistic density functions . . . . .	43
4.5	Comparison of four elliptical distributions . . . . .	43
4.6	Enlargement of the righthand tail . . . . .	44
4.7	The Telser portfolios with different elliptical distributions . . . . .	50
5.1	Definition of Value at Risk . . . . .	54
5.2	The efficient frontier in mean-standard deviation and mean-VaR framework . . . . .	57
5.3	Graphical relationship of the efficient frontier in mean-st.dev. and mean-VaR framework. . . . .	57
5.4	Graphical relationship of the CML in mean-st.dev. and mean- VaR framework. . . . .	58
5.5	The minimum VaR portfolio . . . . .	60

5.6	The minimum VaR portfolio . . . . .	61
5.7	The optimal Telser portfolio . . . . .	62
5.8	The optimal Telser portfolio with risk-free asset . . . . .	63
5.9	QQ-plots of Elsevier, Fortis, Getronics and Heineken. . . . .	65
5.10	QQ-plots of Philips, Royal Dutch and Unilever. . . . .	66
5.11	Optimal Portfolios with VaR constraint. . . . .	70
6.1	Optimal "EVA with allocated capital" portfolio . . . . .	75
6.2	Moving the EVA-line with large $r_{cap}$ . . . . .	76
6.3	Moving the EVA-line with small $r_{cap}$ . . . . .	76
6.4	The tangency point is the Telser point . . . . .	77
6.5	Maximizing the slope of the RAROC-line . . . . .	79
6.6	The situation if the tangency Value at Risk exceeds $VaR_c$ . . . . .	80
6.7	EVA maximization solutions with risk-free asset . . . . .	82
6.8	RAROC maximization solutions with risk-free asset . . . . .	83
6.9	Optimal EVA and RAROC portfolios. . . . .	86
7.1	The standard second order cone . . . . .	89
7.2	The optimal portfolios with uncertainty . . . . .	99
7.3	The new efficient frontiers . . . . .	100

---

# List of Tables

---

1.1	The casino game . . . . .	1
2.1	Expected daily returns . . . . .	21
2.2	Covariances of daily returns . . . . .	21
3.1	Yearly means, standard deviations and correlations . . . . .	33
3.2	$\mu$ and $\Sigma$ of yearly returns ( $\times 10^{-3}$ ) . . . . .	33
4.1	The quantiles $k_\alpha$ for some elliptical distributions . . . . .	48
4.2	The quantiles $k_\alpha$ for some elliptical distributions . . . . .	49
4.3	Optimal Telser allocation $\theta$ for different yearly distributions . . .	49
4.4	The optimal Telser allocation $\theta$ , with risk-free asset, for different yearly distributions. . . . .	50
5.1	Estimated left tail distribution of returns . . . . .	67
5.2	The quantiles for some elliptical distributions at different $\alpha$ . . .	67
5.3	Optimal Telser portfolio results with risk-free asset . . . . .	70
6.1	Overview of the performance measures EVA and RAROC . . . . .	74
7.1	Lower and upper bounds for means . . . . .	96
7.2	Lower and upper bounds for covariances . . . . .	97



---

## List of Symbols

---

### Symbols

$n$	= number of assets.
$C_0$	= capital that can be invested, in euros.
$C_{end}$	= capital at the end of the period, in euros.
$R_p$	= total portfolio return, in euros.
$\mu_p$	= expected portfolio return, in euros.
$\sigma_p^2$	= variance of portfolio return.
$r_i$	= rate of return on asset $i$ .
$\mu_i$	= expected rate of return on asset $i$ .
$\rho_{ij}$	= correlation between asset $i$ and $j$ .
$\sigma_{ij}$	= covariance of asset $i$ and $j$ .
$\Sigma$	= $\begin{pmatrix} \sigma_{11} & \sigma_{12} & \dots & \sigma_{1n} \\ \sigma_{21} & \ddots & & \vdots \\ \vdots & & & \\ \sigma_{n1} & \dots & & \sigma_{nn} \end{pmatrix}$ = matrix of covariances of $r$ .
$\theta_i$	= amount invested in asset $i$ , in euros.
$\mu_f$	= rate of return on the risk-free asset.
$R_f$	= total return on the risk-free asset.
$\gamma$	= parameter of absolute risk aversion.
$s$	= slope of the capital market line in mean-st.dev.framework.
$k_\alpha$	= dispersion-standardized quantile of distribution at level $\alpha$ .
$z_\alpha$	= $\sigma$ -standardized quantile of distribution at confidence level $\alpha$ .
$\Omega$	= $(n \times n)$ -dispersion matrix.
$VaR_\alpha$	= Value at Risk at confidence level $(1 - \alpha)$ .
$r_{cap}$	= cost of capital rate.

$$\begin{aligned}
\Sigma^0 &= (n \times n)\text{-matrix of average covariances.} \\
\Sigma^L &= (n \times n)\text{-matrix of lowest covariances.} \\
\Sigma^U &= (n \times n)\text{-matrix of highest covariances.} \\
\Delta &= \Sigma^U - \Sigma^0. \\
\mu^0 &= (n \times 1)\text{-vector of average means.} \\
\mu^L &= (n \times 1)\text{-vector of lowest means.} \\
\mu^U &= (n \times 1)\text{-vector of highest means.} \\
\beta &= \mu^U - \mu^0. \\
\|\cdot\| &= \text{Euclidean norm.} \\
r &= \begin{pmatrix} r_1 \\ r_2 \\ \vdots \\ r_n \end{pmatrix}, \mu = \begin{pmatrix} \mu_1 \\ \mu_2 \\ \vdots \\ \mu_n \end{pmatrix}, \theta = \begin{pmatrix} \theta_1 \\ \theta_2 \\ \vdots \\ \theta_n \end{pmatrix}, \bar{1} = \begin{pmatrix} 1 \\ 1 \\ \vdots \\ 1 \end{pmatrix}
\end{aligned}$$

## Expressions

With this symbols we can derive the following (logical) expressions. Notice that the vector notation is used throughout this thesis.

1.  $C_{end} = C_0 + R_p.$
2.  $R_p = \sum_{i=0}^n r_i \theta_i = r^T \theta.$
3.  $\mu_p = \sum_{i=0}^n \mu_i \theta_i = \mu^T \theta.$
4.  $\sigma_p^2 = \sum_{i=0}^n \sum_{j=0}^n \theta_i \theta_j \sigma_{ij} = \theta^T \Sigma \theta.$
5.  $R_f = \mu_f C_0.$

---

# Introduction

---

This thesis is about portfolio optimization. But what is an optimal portfolio? Consider the following example:

Suppose you are at the casino and there are two games to play. In the first game, there is a probability of 5% of winning 1000 euro and a 95% chance of winning nothing. The second game also has a 5 percent winning chance, but you will win 5000 euro. On the contrary, if you lose, then you have to pay the casino 200 euro. The facts are in the table below.

game I		game II	
5%:	+1000 euro	5%:	+5000 euro
95%:	0 euro	95%:	-200 euro

Table 1.1: The casino game

You are allowed to play the game once. Which game will you choose?

Most people will choose for game I. It is interesting to see why. The expected return for the first game is  $(0.05 \times 1000) + (0.95 \times 0) = 50$ , while the expected return for game II is  $(0.05 \times 5000) + (0.95 \times -200) = 60$ . Looking at the expected return, it is more logical to play the second game! Nevertheless, in spite of this statistical fact, game I is the most popular. The explanation is that game II appears to be more *risky* than game I. But what is risk? Risk can be defined in many ways, and for each person this definition of risk can be different. However, most people have one thing in common: they all are *risk averse*.

A risk averse investor doesn't like to take risk. If he can choose between two investments with the same expected return, he will choose the less risky one.



The opposite of a risk averse investor is a risk loving investor. If a risk loving investor can choose between two investments with the same expected return, he will choose the most risky one. This seems a bit strange, but consider for example a person who desperately needs 5000 euros. He will strongly consider to take on the risky game II and is willing to take more risk to achieve his goal. Although risk loving behavior is a common type of investing strategy, the models in this thesis assume that each investor doesn't like to take more risk than necessary, and thus is risk averse.

Let's return to the example. We said that game II is the more risky game. This seems plausible, but we have not defined what risk is. As stated before, it can be defined in many ways. Suppose gambler A uses the following definition of risk: *The more chance there is of losing money, the more risky the investment.* In his case, game I is risk-free, because you never lose money, and game II is full of risk, because there is a 95% chance of losing something. Gambler B uses another definition: *The more dispersion in the outcomes of the investment, the more risky it is.* Dispersion can be measured by standard deviation. The higher the dispersion, the more the outcomes are expected to differ from the expected value. Looking at the example, game I has a standard deviation of

$$\text{stdev(I)} = \sqrt{0.05 \times (1000 - 50)^2 + 0.95 \times (0 - 50)^2} = 218,$$

while game II's dispersion can be written as

$$\text{stdev(II)} = \sqrt{0.05 \times (5000 - 60)^2 + 0.95 \times (-200 - 60)^2} = 1133.$$

So the dispersion of game II is more than five times higher than the dispersion of game I, and that is why gambler B will choose to play the first game, in spite of the lower expected return.

In the theory of portfolio optimization, the risk measure of standard deviation is very popular. In 1952 Harry Markowitz wrote a paper about modern portfolio theory, where he explained an optimization method for risk averse investors. He won the Nobel prize for his work in 1990. His mean-variance analysis (the variance is the squared standard deviation) is used in many papers since. Basic thought is finding the best combination of mean(expected return) and variance(risk) for each investor.

This thesis tries to go beyond the theory of Markowitz. Extensions of this theory are made to make the optimization of portfolios more applicable to the current needs of, for example, a bank. This thesis gives a wide mathematical overview of the possible models that can be used for the optimization of portfolios.

## Overview of this thesis

The thesis starts with a broad mathematical view of the theory of Markowitz in chapter 2. The theory of the efficient set is explained and optimal portfolios are calculated. We see what happens when a risk-free asset is added to the model and a sensitivity analysis is done. Chapter 3 introduces a safety first

---

principle, another model for portfolio optimization which deals with shortfall probabilities. A shortfall probability is the chance that the return of the portfolio will be lower than a predetermined value. The assumption of normally distributed portfolio returns is made in this chapter. Chapter 4 discusses the family of elliptical distributions. We see what happens with the safety first model if an elliptical distribution, instead of a normal distribution, is used as the density function for returns. The widely used risk measure *Value at Risk* (VaR) is discussed in chapter 5, and optimal portfolios considering this other risk measure are derived. Both the case with and without risk-free asset are discussed. Chapter 6 introduces the performance measures EVA (Economic Value Added) and RAROC (Risk Adjusted Return On Capital), and implements these in the previous models. Two proposals of dealing with uncertainty in the input parameters are given in chapter 7. Here, the technique of second order cone programming (SOCP) is used for solving the problems. Chapter 8 concludes this thesis with a concluding example and recommendations for future research. Some large or complex calculations and four MATLAB computer programs are placed in the appendices. An example for illustrating the discussed models and the references are placed at the end of each chapter.



---

# The portfolio theory of Markowitz

---

This chapter is all about the theory of Markowitz. The theory is explained in a short and mathematical way, and all interesting portfolios are calculated. Please look at the references if the theory is too abstract, a nice introduction of the Markowitz theory can be found, for example, in Elton, Gruber (1981) and Blake (1990).

The efficient frontier is discussed in section 1. The minimum variance portfolio, tangency portfolio and the optimal utility maximizing portfolio are dealt with in sections 2, 3 and 4. In section 5 a risk-free asset is added to the model, and new optimal policies are determined. A sensitivity analysis is taken in section 6 and we introduce an example in section 7. The last section contains the references for this chapter.

## 2.1 Efficient frontier

The efficient frontier is the curve that shows all efficient portfolios in a risk-return framework. An efficient portfolio is defined as the portfolio that maximizes the expected return for a given amount of risk (standard deviation), or the portfolio that minimizes the risk subject to a given expected return.

An investor will always invest in an efficient portfolio. If he desires a certain amount of risk, he would be crazy if he doesn't aim for the highest possible expected return. The other way the same holds. If he wants a specific expected return, he likes to achieve this with the minimum possible amount of risk. This is because the investor is risk averse.

So, to calculate the efficient frontier we have to minimize the risk (standard deviation) given some expected return. The objective function is the function that has to be minimized, which is the standard deviation. However, we take the variance (the squared standard deviation) as the objective function, which

is allowed because the standard deviation can only be positive. The objective function is

$$\text{var}(C_{end}) = \text{var}(C_0 + R_p) = \text{var}(R_p) = \text{var}(r^T \theta) = \theta^T \Sigma \theta.$$

There are two constraints that must hold for minimizing this objective function. First, the expected return must be fixed, because we are minimizing the risk given this return. This fixed portfolio mean is defined by  $\mu_p$ . The second constraint is that we can only invest the capital we have at this moment, so the amounts we invest in each single asset must add up to this amount  $C_0$ . This gives the following two constraints:

$$\mu^T \theta = \mu_p \quad \text{and} \quad \bar{1}^T \theta = C_0$$

We are looking for the investment policy with minimum variance, so we have to solve the following problem:

$$\text{Min} \{ \theta^T \Sigma \theta \mid A^T \theta = B \}$$

with

$$A = \begin{pmatrix} \mu & \bar{1} \end{pmatrix} \quad \text{and} \quad B = \begin{pmatrix} \mu_p \\ C_0 \end{pmatrix}$$

We use the Lagrange method to solve this system. We get the following conditions, where  $\lambda_0$  is the Lagrange multiplier:

$$\begin{cases} 2\Sigma\theta + A\lambda_0 = 0 \\ A^T\theta = B \end{cases} \quad \text{with} \quad \lambda_0 = \begin{pmatrix} \lambda_1 \\ \lambda_2 \end{pmatrix} \quad (2.1)$$

Solving the first equation of (2.1) for  $\theta$  gives, with a redefinition of the vector  $\lambda = -1/2\lambda_0$

$$\theta = \Sigma^{-1}A\lambda$$

So the second equation of (2.1) becomes

$$A^T \Sigma^{-1} A \lambda = B \quad \Rightarrow \quad \lambda = (A^T \Sigma^{-1} A)^{-1} B \equiv H^{-1} B$$

where  $H = (A^T \Sigma^{-1} A)$  and  $H^T = (A^T \Sigma^{-1} A)^T = A^T (\Sigma^{-1})^T A = A^T \Sigma^{-1} A = H$ , so  $H$  is a symmetric (2x2)-matrix. Filling in these expressions in the variance formula, we get

$$\text{var}(R_p) = \theta^T \Sigma \theta = \theta^T \Sigma \Sigma^{-1} A \lambda = \theta^T A \lambda = (A^T \theta)^T H^{-1} B = B^T H^{-1} B$$

We have seen that  $H$  is a symmetric  $(2 \times 2)$ -matrix, so suppose that

$$H \equiv \begin{pmatrix} a & b \\ b & c \end{pmatrix} \quad \Rightarrow \quad H^{-1} = \frac{1}{ac - b^2} \begin{pmatrix} c & -b \\ -b & a \end{pmatrix}$$

Define  $d \equiv \det(H) = ac - b^2$ . Because  $H = (A^T \Sigma^{-1} A)$  it is easy to see that:

$$\begin{aligned} a &= \mu^T \Sigma^{-1} \mu, \\ b &= \mu^T \Sigma^{-1} \bar{1} = \bar{1}^T \Sigma^{-1} \mu, \\ c &= \bar{1}^T \Sigma^{-1} \bar{1}. \\ d &= ac - b^2 \end{aligned}$$

We will show that parameters  $a$ ,  $c$  and  $d$  are positive: Because we have assumed that the covariance matrix  $\Sigma$  is positive definite, the inverse matrix  $\Sigma^{-1}$  is also positive definite. This means that  $x^T \Sigma^{-1} x > 0$  for all nonzero  $(N \times 1)$ -vectors  $x$ , so it is clear that

$$a > 0, \quad c > 0$$

But also  $(b\mu - a\bar{1})^T \Sigma^{-1} (b\mu - a\bar{1}) = bba - abb - abb + aac = a(ac - b^2) = ad > 0$ , and because  $a > 0$  we know that

$$d > 0$$

With the definition of  $H$  our expression for the variance becomes

$$\begin{aligned} \text{var}(R_p) &= \frac{1}{d} \begin{pmatrix} \mu_p & C_0 \end{pmatrix} \begin{pmatrix} c & -b \\ -b & a \end{pmatrix} \begin{pmatrix} \mu_p \\ C_0 \end{pmatrix} \\ &= \frac{1}{d} (c\mu_p^2 - 2bC_0\mu_p + aC_0^2) \end{aligned}$$

This gives the expression for the efficient frontier in a risk-return framework. Note that only the upper half of this graph is the efficient set, because portfolios at the lower half can be chosen on the upper half so more return is obtained with the same level of risk. The formula of the efficient frontier is given by

$$\sigma_p^2 = \frac{1}{d} (c\mu_p^2 - 2bC_0\mu_p + aC_0^2) \quad (2.2)$$

Taking the square root of this formula gives an expression for the standard deviation. The graph of the efficient frontier is shown in the next figure, where the mean-standard deviation space is used. These are the axes we will use in the next chapters.

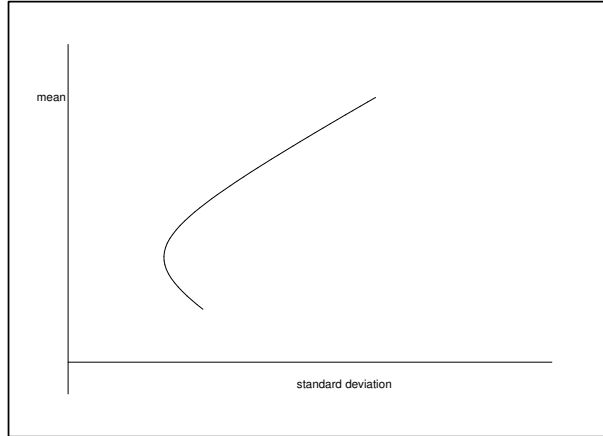

Figure 2.1: The efficient frontier

This is a parabola in  $(\sigma_p^2, \mu_p)$ -space. However, in the  $(\sigma_p, \mu_p)$ -space we are using, this is the right side of a hyperbola. This is easily seen by noticing the following:

$$\sigma_p^2 = \frac{c\mu_p^2 - 2bC_0\mu_p + aC_0^2}{d} = \frac{c\mu_p^2 - 2bC_0\mu_p + dC_0^2/c + b^2C_0^2/c}{d}$$

so we have, by dividing the left side by  $1/c$  and the right side by  $c/c^2$ ,

$$\frac{\sigma_p^2}{1/c} = \frac{\mu_p^2 - 2bC_0/c\mu_p + dC_0^2/c^2 + b^2C_0^2/c^2}{d/c^2} = \frac{(\mu_p - bC_0/c)^2}{d/c^2} + C_0^2$$

which is the formula of the following hyperbola:

$$\frac{\sigma_p^2}{C_0^2/c} - \frac{(\mu_p - bC_0/c)^2}{dC_0^2/c^2} = 1$$

The slopes of the two asymptotes are  $\pm\sqrt{\frac{dC_0^2/c^2}{C_0^2/c}} = \pm\sqrt{\frac{d}{c}}$  and the center of the hyperbola is  $(0, \frac{b}{c}C_0)$ , so the asymptotes are given by

$$\mu_p = \frac{b}{c}C_0 \pm \sqrt{\frac{d}{c}}\sigma_p.$$

We are especially interested in the portfolio allocation  $\theta_{EF}$  belonging to the efficient frontier. This gives the amounts an investor must invest in the single assets to achieve the expected return and risk on the efficient frontier. We have

$$\begin{aligned} \theta_{EF} &= \Sigma^{-1}A\lambda = \Sigma^{-1}AH^{-1}B = \frac{c\mu_p - bC_0}{d}\Sigma^{-1}\mu + \frac{aC_0 - b\mu_p}{d}\Sigma^{-1}\bar{1} \\ &= \frac{1}{d}\Sigma^{-1}((a\bar{1} - b\mu)C_0 + (c\mu - b\bar{1})\mu_p) \end{aligned} \quad (2.3)$$

So for each desired value of the portfolio return  $\mu_p$ , both the corresponding minimum standard deviation and the corresponding allocation can be calculated, using (2.2) respectively (2.3).

## 2.2 Minimum variance portfolio

Suppose an investor desires to invest in a portfolio with the least amount of risk. He doesn't care about his expected return, he only wants to invest all his money with the lowest possible amount of risk. Because he will always invest in an efficient portfolio, he will choose the portfolio on the efficient frontier with minimum standard deviation. At this point, also the variance is minimal. That is why this portfolio is called the *minimum variance portfolio*. The graphical interpretation of the minimum variance portfolio is shown in the next figure.

This minimum variance portfolio can be calculated by minimizing the variance subject to the necessary constraint that an investor can only invest the amount of capital he has. This is called the *budget constraint*. The minimization problem is

$$\text{Min} \{ \theta^T \Sigma \theta \mid \bar{1}^T \theta = C_0 \}$$

Using Lagrange to solve this set, we get

$$\begin{cases} 2\Sigma\theta + \bar{1}\lambda_0 = 0 \\ \bar{1}^T\theta = C_0 \end{cases} \quad \text{with } \lambda_0 \text{ a constant} \quad (2.4)$$

Solving the first equation of (2.4) for  $\theta$  gives, with a new constant  $\lambda = -1/2\lambda_0$ :

$$\theta = \Sigma^{-1}\bar{1}\lambda$$

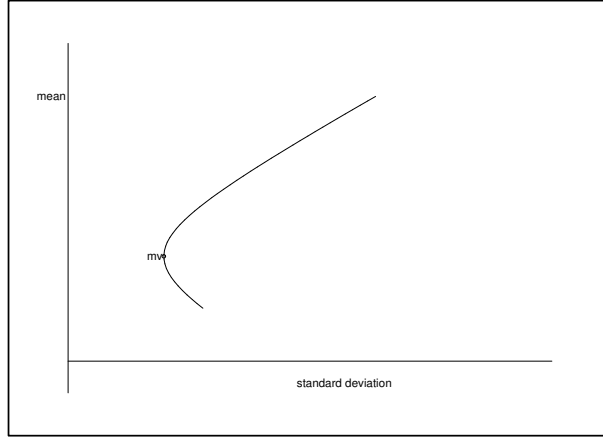

Figure 2.2: The minimum variance portfolio

Using this expression for  $\theta$  in the second equation of (2.4) gives

$$\bar{\mathbf{1}}^T \Sigma^{-1} \bar{\mathbf{1}} \lambda = C_0 \quad \Rightarrow \quad \lambda = \frac{C_0}{\bar{\mathbf{1}}^T \Sigma^{-1} \bar{\mathbf{1}}} \equiv \frac{C_0}{c}$$

where  $c = \bar{\mathbf{1}}^T \Sigma^{-1} \bar{\mathbf{1}}$  is defined as the element  $h_{22}$  in the matrix  $H$  in the previous section. Filling in this expression for  $\lambda$  in the above expression for  $\theta$  gives

$$\theta_{mv} = \Sigma^{-1} \bar{\mathbf{1}} \frac{C_0}{c} \quad (2.5)$$

the portfolio allocation when an investor desires minimum risk. We can express the amount of risk in the minimum variance portfolio by calculating the minimum variance:

$$\begin{aligned} \sigma_{mv}^2 &= \theta^T \Sigma \theta = \frac{C_0}{c} (\Sigma^{-1} \bar{\mathbf{1}})^T \Sigma \frac{C_0}{c} \Sigma^{-1} \bar{\mathbf{1}} = \left( \frac{C_0}{c} \right)^2 \bar{\mathbf{1}}^T (\Sigma^{-1})^T \Sigma \Sigma^{-1} \bar{\mathbf{1}} \\ &= \left( \frac{C_0}{c} \right)^2 \bar{\mathbf{1}}^T \Sigma^{-1} \bar{\mathbf{1}} = \left( \frac{C_0}{c} \right)^2 c = \frac{C_0^2}{c} \end{aligned}$$

The expected return on this minimum variance portfolio is

$$\mu_{mv} = \mu^T \theta = \mu^T \Sigma^{-1} \bar{\mathbf{1}} \frac{C_0}{c} = b \frac{C_0}{c} = \frac{b}{c} C_0$$

The attentive reader will notice that this minimum variance also can be calculated by differentiating the formula for the efficient frontier in the previous section, and then set it equal to zero. It can be shown that this gives the same result.

## 2.3 Tangency portfolio

Suppose an investor has other preferences than taking the least possible amount of risk and thus investing in the minimum variance portfolio. An example of



another preference is investing in the portfolio with maximum *Sharpe ratio*. The Sharpe ratio is defined as the return-risk ratio, so

$$\text{Sharpe ratio} = \frac{\text{mean}}{\text{standard deviation}}$$

It represents the expected return per unit of risk, so the portfolio with maximum Sharpe ratio gives the highest expected return per unit of risk, and is thus the most "risk-efficient" portfolio.

Graphically, the portfolio with maximum Sharpe ratio is the point where a line through the origin is tangent to the efficient frontier, in mean-standard deviation space, because this point has the property that it has the highest possible mean-standard deviation ratio. That is why we call this the *tangency portfolio*. See the next figure for the graph.

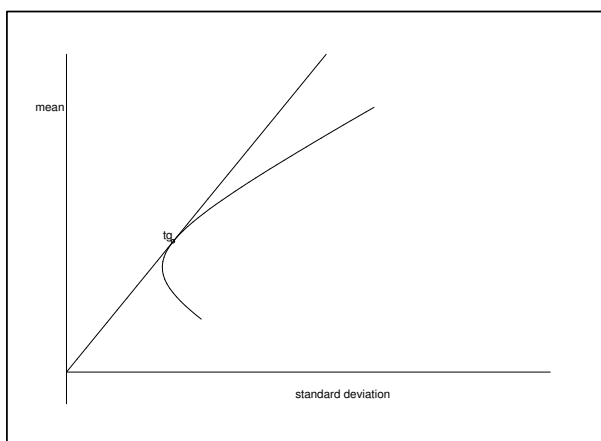

Figure 2.3: The tangency portfolio

For the calculation of the tangency portfolio we need the formula for the efficient frontier. Remember it is given by

$$\sigma_p = \sqrt{\frac{1}{d}(c\mu_p^2 - 2bC_0\mu_p + aC_0^2)}.$$

Suppose that the tangency point has coordinates  $(\sigma_{tg}, \mu_{tg})$ . Then the (inverse of the) slope of the tangency line is

$$\frac{\Delta\sigma_p}{\Delta\mu_p} = \frac{\sqrt{\frac{1}{d}(c\mu_{tg}^2 - 2bC_0\mu_{tg} + aC_0^2)} - 0}{\mu_{tg} - 0}.$$

The slope of the efficient frontier at the tangency point is simply the derivative of the efficient frontier at that point. The (inverse of the) slope is

$$\begin{aligned} \frac{\partial\sigma_p}{\partial\mu_p} &= \frac{1}{2} \left( \frac{1}{d}(c\mu_p^2 - 2bC_0\mu_p + aC_0^2) \right)^{-1/2} \frac{1}{d}(2c\mu_p - 2bC_0) \Big|_{\mu_p=\mu_{tg}} \\ &= \frac{c\mu_{tg} - bC_0}{d\sqrt{\frac{1}{d}(c\mu_{tg}^2 - 2bC_0\mu_{tg} + aC_0^2)}}. \end{aligned}$$

At the tangency point the two slopes must be equal, so

$$\frac{\sqrt{\frac{1}{d}(c\mu_{tg}^2 - 2bC_0\mu_{tg} + aC_0^2)}}{\mu_{tg}} = \frac{c\mu - bC_0}{d\sqrt{\frac{1}{d}(c\mu_{tg}^2 - 2bC_0\mu_{tg} + aC_0^2)}}$$

$$\Rightarrow \mu_{tg} = \frac{a}{b}C_0.$$

The corresponding  $\sigma_{tg}$  is calculated by filling in  $\mu_{tg}$  in the efficient frontier formula. This gives

$$\sigma_{tg} = \sqrt{\frac{1}{d}\left(c\frac{a^2}{c^2}C_0^2 - \frac{2ab}{b}C_0^2 + aC_0^2\right)} = \frac{\sqrt{a}}{b}C_0.$$

where we used that  $d = ac - b^2$ .

To get  $\theta_{tg}$ , the allocation of the assets at the tangency point, we use formula (2.3), which gives

$$\theta_{tg} = \frac{c\frac{a}{b}C_0 - bC_0}{d}\Sigma^{-1}\mu + \frac{aC_0 - b\frac{a}{b}C_0}{d}\Sigma^{-1}\bar{1}$$

$$= \Sigma^{-1}\mu\frac{C_0}{b}. \quad (2.6)$$

So when an investor desires the maximization of the Sharpe ratio of his portfolio, his optimal asset allocation is  $\theta_{tg}$ .

## 2.4 Optimal portfolio

So far, we have seen two portfolios an investor can prefer. If he desires a minimum amount of risk he takes on the minimum variance portfolio. If the objective is to maximize the portfolio's Sharpe ratio, the tangency portfolio is taken.

The theory of Markowitz however, assumes a different kind of preference for the investor. It says the investors goal is to maximize his utility function, where the utility is given by

$$u = E(C_{end}) - \frac{1}{2}\gamma var(C_{end}). \quad (2.7)$$

So utility is a function of the expected return, variance and a new parameter  $\gamma$ . This  $\gamma$  is called the parameter of absolute risk aversion. As the name indicates, it is a measure of the investors risk averseness. It can be different for each investor, and even for an investor it can change through time. The greater the  $\gamma$ , the more risk averse the investor is. This is easily verified, because in the utility function (2.7) the parameter that indicates the risk, the variance, becomes more important when  $\gamma$  is greater. And because a greater risk results in a lower utility, the investor with the greater  $\gamma$  is more risk averse than an investor with lower  $\gamma$ . The parameter of absolute risk aversion is assumed to be positive, because all investors are assumed to be risk averse. A negative  $\gamma$  would imply that an investor is risk loving.

The optimal portfolio for an investor is the portfolio with maximum utility. The utility function (2.7) can be written as

$$\begin{aligned} E(C_{end}) - \frac{1}{2}\gamma var(C_{end}) &= E(C_0 + R_p) - \frac{1}{2}\gamma var(C_0 + R_p) = C_0 + \mu_p - \frac{1}{2}\gamma var(R_p) \\ &= C_0 + \mu^T \theta - \frac{1}{2}\gamma \sigma_p^2 = C_0 + \mu^T \theta - \frac{1}{2}\gamma \theta^T \Sigma \theta \end{aligned} \quad (2.8)$$

Graphically, the portfolio with maximum utility is gained by moving the utility curve as high as possible. The utility curve is the curve that shows the possible combinations of mean and standard deviation that result in the same utility. Because of (2.8), it is given by

$$\mu_p = u - C_0 + \frac{1}{2}\gamma \sigma_p^2$$

which is a parabola in mean-standard deviation space. The figure shows some utility curves together with the optimal portfolio, that is reached at the highest possible utility curve.

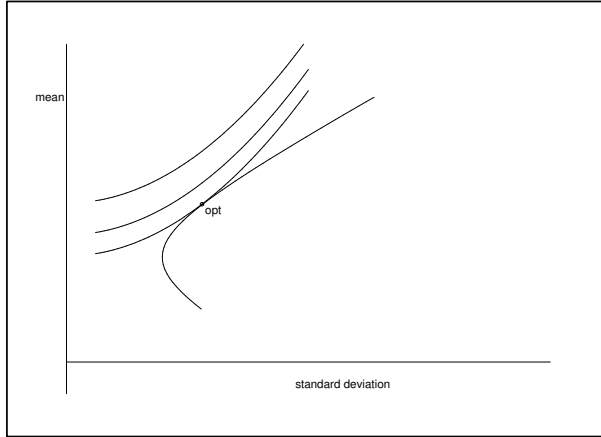

Figure 2.4: The optimal portfolio

In order to calculate the optimal portfolio, we have to maximize the utility subject to the budget constraint:

$$Max \{ C_0 + \mu^T \theta - \frac{1}{2}\gamma \theta^T \Sigma \theta \mid \bar{1}^T \theta = C_0 \}.$$

Again we are using the Lagrange method for solving this set of equations:

$$\begin{cases} \mu - \frac{1}{2}\gamma 2\Sigma \theta + \bar{1}\lambda = 0 \\ \bar{1}^T \theta = C_0 \end{cases} \quad \text{with } \lambda \text{ a constant} \quad (2.9)$$

Solving the first equation of (2.9) for  $\theta$  gives

$$\mu + \bar{1}\lambda = \gamma \Sigma \theta \quad \Rightarrow \quad \theta = \frac{\Sigma^{-1}\mu}{\gamma} + \frac{\lambda \Sigma^{-1}\bar{1}}{\gamma} \quad (2.10)$$

Using this expression for  $\theta$  in the second equation of (2.9) we get:

$$\bar{1}^T \left( \frac{\Sigma^{-1}\mu}{\gamma} + \frac{\lambda\Sigma^{-1}\bar{1}}{\gamma} \right) = C_0 \quad \Rightarrow \quad \frac{\bar{1}^T\Sigma^{-1}\mu}{\gamma} + \frac{\bar{1}^T\Sigma^{-1}\bar{1}\lambda}{\gamma} = C_0$$

We apply the elements  $b$  and  $c$  of the matrix  $H$ , which is defined in the previous sections, to make this expression easier, so

$$\frac{b}{\gamma} + \frac{c\lambda}{\gamma} = C_0 \quad \Rightarrow \quad \lambda = \frac{\gamma C_0 - b}{c}$$

Since we know  $\lambda$  we can finish the expression for  $\theta$  derived in (2.10):

$$\theta_{opt} = \frac{\Sigma^{-1}\mu}{\gamma} + \frac{\Sigma^{-1}\bar{1}}{\gamma} \left( \frac{\gamma C_0 - b}{c} \right) = \frac{1}{\gamma} \Sigma^{-1} \left( \mu + \bar{1} \left( \frac{\gamma C_0 - b}{c} \right) \right)$$

which are the amounts an investor should invest in each asset if he desires to maximize his utility. We can simplify this expression by using (2.5) for the minimum variance portfolio and (2.6) for the tangency portfolio. Rearranging these formulas gives

$$\Sigma^{-1}\bar{1} = \frac{c}{C_0} \theta_{mv} \quad \text{and} \quad \Sigma^{-1}\mu = \frac{b}{C_0} \theta_{tg}$$

We use these expressions in the optimal portfolio  $\theta_{opt}$ :

$$\begin{aligned} \theta_{opt} &= \frac{b}{C_0\gamma} \theta_{tg} + \frac{c}{C_0} \left( \frac{C_0 - b/\gamma}{c} \right) \theta_{mv} \\ &= \frac{b}{C_0\gamma} \theta_{tg} + \left( 1 - \frac{b}{\gamma C_0} \right) \theta_{mv} \end{aligned} \quad (2.11)$$

We see that the optimal portfolio is a combination of the minimum variance portfolio and the tangency portfolio, where a proportion  $\alpha = \frac{b}{\gamma C_0}$  is invested in the tangency portfolio and a proportion  $1 - \alpha$  in the minimum variance portfolio.

The corresponding values for  $\mu_p$  and  $\sigma_p^2$  are

$$\begin{aligned} \mu_{opt} &= \mu^T \theta = \frac{\mu^T \Sigma^{-1} \mu}{\gamma} + \mu^T \Sigma^{-1} \bar{1} \left( \frac{C_0 - b/\gamma}{c} \right) \\ &= \frac{a}{\gamma} + \frac{b}{c} \left( C_0 - \frac{b}{\gamma} \right) = \frac{ac - b^2}{c\gamma} + \frac{b}{c} C_0 = \frac{d}{c\gamma} + \mu_{mv} \end{aligned}$$

and

$$\sigma_{opt}^2 = \theta^T \Sigma \theta = \frac{ac - b^2 + \gamma^2 C_0^2}{c\gamma^2} = \frac{d}{c\gamma^2} + \sigma_{mv}^2$$

We see that the mean and variance of the optimal portfolio is determined by the values for the minimum variance portfolio plus an amount which depends on the coefficient of absolute risk aversion ( $\gamma$ ).

When an investor is absolute risk averse, so doesn't want to take on any risk, the  $\gamma$  will go to infinity and the optimal portfolio will be the minimum variance portfolio. Thus an investor with an infinite parameter of risk aversion will invest in the minimum variance portfolio. If  $\gamma = \frac{b}{C_0}$  it is easily seen (by substituting this in the optimal portfolio formula) that the optimal portfolio is identical to the tangency portfolio, or the portfolio with maximum Sharpe ratio. So both the minimum variance and the tangency objective function are special cases of the utility maximizing Markowitz strategy.

## 2.5 Adding a risk-free asset

In this section we will assume that an investor can also choose to invest in a risk-free asset. A risk-free asset  $x_f$  is an asset with a (low) return, but with no risk at all, so  $\sigma_f = 0$ . This means that the expected return will be the realized return. Furthermore, the risk-free asset is uncorrelated with the risky assets, so  $\rho_{i,f} = \text{cov}(x_i, x_f) = 0$  for all risky assets  $i$ .

An investor can both lend and borrow at the risk-free rate. Lending means a positive amount is invested in the risk-free asset ( $\theta_f > 0$ ), borrowing implicates that  $\theta_f < 0$ . If  $\theta_f = 0$ , we have the same situation as without risk-free asset. As an example of a risk-free asset a government bond is usually taken. It is not absolute risk-free, but it approaches the desired constancy in returns and insensitivity with the risky assets.

### 2.5.1 Capital market line & market portfolio

The efficient frontier changes when a risk-free asset is included. The theory of Markowitz (see for example Elton, Gruber (1981)) learns that the new efficient frontier is a straight line, starting at the risk-free point and tangent to the old efficient frontier. The new efficient frontier is called the *Capital Market Line* (CML), and we still refer to the old frontier as the efficient frontier. The tangency point between the CML and the efficient frontier is called the *market portfolio*. See the figure for a graphical representation.

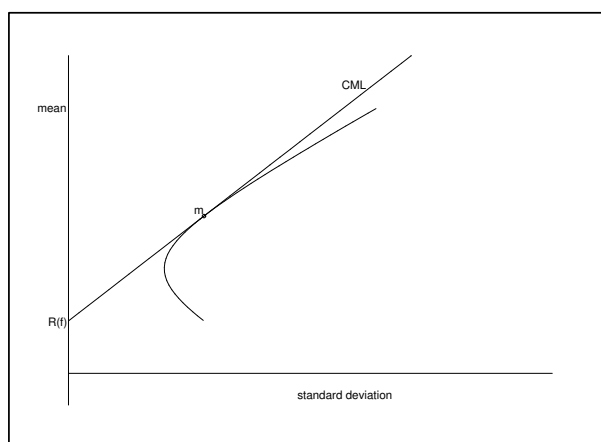

Figure 2.5: The market portfolio and Capital Market Line

We will calculate the CML and show that the new efficient frontier indeed is the straight line from the theory. Suppose that an amount  $\theta_f$  is invested in the risk-free asset and that the return on the risk-free asset is  $\mu_f$ . Because the risk-free asset is uncorrelated with the risky assets we have the following relationships:

$$\sigma_p^2 = \theta^T \Sigma \theta \quad \text{and} \quad \mu_p = \mu^T \theta + \mu_f \theta_f.$$

The budget constraint changes in

$$\bar{\mathbf{1}}^T \theta + \theta_f = C_0.$$

The efficient frontier is the minimization of the variance subject to a fixed mean, or the maximization of the expected return given some variance. Because the first definition is used in the first section (to derive the efficient frontier), we use the second definition now. Of course, for the results it does not matter which of the two definitions is used. The problem is

$$\text{Max} \left\{ \begin{array}{l} \mu^T \theta + \mu_f \theta_f \\ \bar{1}^T \theta + \theta_f = C_0 \\ \sigma_p^2 = \theta^T \Sigma \theta \end{array} \right\}.$$

Using Lagrange to solve this system gives, after noticing that the maximization of  $\mu^T \theta + \mu_f \theta_f$  is identical to the minimization of  $-\mu^T \theta - \mu_f \theta_f$ :

$$\left\{ \begin{array}{ll} -\mu + \lambda_1 \bar{1} + 2\lambda_2 \Sigma \theta = 0 & (a) \\ -\mu_f + \lambda_1 = 0 & (b) \\ \bar{1}^T \theta + \theta_f = C_0 & (c) \\ \sigma_p^2 = \theta^T \Sigma \theta & (d) \end{array} \right.$$

Equation (b) gives  $\lambda_1 = \mu_f$ , which is substituted in (a):

$$-\mu + \mu_f \bar{1} + 2\lambda_2 \Sigma \theta = 0 \iff \theta = \frac{1}{2\lambda_2} \Sigma^{-1} (\mu - \mu_f \bar{1}). \quad (2.12)$$

Using this in (d), an expression for  $\lambda_2$  can be calculated. We get

$$\sigma_p^2 = \theta^T \Sigma \theta = \frac{1}{4\lambda_2^2} (\mu - \mu_f \bar{1})^T \Sigma^{-1} (\mu - \mu_f \bar{1}) = \frac{1}{4\lambda_2^2} (c\mu_f^2 - 2b\mu_f + a).$$

So

$$\lambda_2 = \sqrt{\frac{c\mu_f^2 - 2b\mu_f + a}{4\sigma_p^2}} = \frac{1}{2\sigma_p} \sqrt{c\mu_f^2 - 2b\mu_f + a}$$

We have not used (c) so far. This gives us an expression for  $\theta_f$ :

$$\theta_f = C_0 - \bar{1}^T \theta = C_0 - \frac{1}{2\lambda_2} \bar{1}^T \Sigma^{-1} (\mu - \mu_f \bar{1}) = C_0 - \frac{1}{2\lambda_2} (b - c\mu_f).$$

But then we have for the expected portfolio return  $\mu_p$  the following expression:

$$\begin{aligned} \mu_p &= \mu^T \theta + \mu_f \theta_f = \frac{1}{2\lambda_2} \mu^T \Sigma^{-1} (\mu - \mu_f \bar{1}) + \mu_f C_0 - \frac{1}{2\lambda_2} (b - c\mu_f) \mu_f \\ &= \frac{1}{2\lambda_2} (c\mu_f^2 - 2b\mu_f + a) + \mu_f C_0 = \frac{c\mu_f^2 - 2b\mu_f + a}{\sqrt{c\mu_f^2 - 2b\mu_f + a}} \sigma_p + \mu_f C_0 \\ &= \left( \sqrt{c\mu_f^2 - 2b\mu_f + a} \right) \sigma_p + \mu_f C_0 \equiv s\sigma_p + \mu_f C_0. \end{aligned} \quad (2.13)$$

This is the efficient frontier when the risk-free asset is added, or the CML. It is a straight line in mean-standard deviation space with slope  $\sqrt{c\mu_f^2 - 2b\mu_f + a} \equiv s$  and it intersects the mean-axis at height  $\mu_f C_0$ . This is the return when the whole capital is invested in the risk-free asset.

The optimal allocation on the CML is given by

$$\theta_{CML} = \frac{\mu_p - \mu_f C_0}{s^2} \Sigma^{-1} (\mu - \mu_f \bar{1}).$$

This result is achieved by using (2.12), the expression for  $\lambda_2$  and the expression for  $\sigma_p$  in terms of  $\mu_p$ . The corresponding amount that is invested in the risk-free asset is the "not used" amount, which is

$$\theta_{f,CML} = C_0 - \bar{1}^T \theta_{CML} = C_0 - \frac{\mu_p - \mu_f C_0}{s^2} (b - c\mu_f).$$

The market portfolio should be the portfolio that is the point of tangency between the efficient frontier and the CML. This is the portfolio on the CML where nothing is invested in the risk-free asset. If the investor goes on the left side of the market portfolio, he invests a proportion in the risk-free asset. If he chooses the right side of the market portfolio, he borrows at the risk-free rate.

The market portfolio is calculated by equalizing the efficient frontier to the CML. First we rewrite the CML (2.13) to

$$\sigma_p = \frac{\mu_p - \mu_f C_0}{s}.$$

Then equalizing the efficient frontier and the CML gives

$$\sigma_p = \sqrt{\frac{1}{d}(c\mu_p^2 - 2b\mu_p C_0 + aC_0^2)} = \frac{\mu_p - \mu_f C_0}{s}.$$

This equation is solved in Appendix A. It results in one solution, so the market portfolio indeed is the point of tangency between the efficient frontier and the CML. The solution is

$$\mu_m = \frac{a - b\mu_f}{b - c\mu_f} C_0, \quad \sigma_m = \frac{s}{b - c\mu_f} C_0$$

with  $s = \sqrt{c\mu_f^2 - 2b\mu_f + a}$ . Since we know the values for mean and variance of the market portfolio, we can calculate, using (2.3), the value for  $\theta$  at the market portfolio:

$$\begin{aligned} \theta_m &= \frac{c \left( \frac{a - b\mu_f}{b - c\mu_f} C_0 \right) - bC_0}{d} \Sigma^{-1} \mu + \frac{aC_0 - b \left( \frac{a - b\mu_f}{b - c\mu_f} C_0 \right)}{d} \Sigma^{-1} \bar{1} \\ &= \Sigma^{-1} (\mu - \mu_f \bar{1}) \frac{C_0}{b - c\mu_f} \end{aligned}$$

A little calculation shows that an investor with parameter of absolute risk aversion  $\gamma = \frac{b - c\mu_f}{C_0}$ , who likes to invest in the optimal, utility maximizing, portfolio as defined in the previous chapter, will invest in the market portfolio.

Since we know the allocation at the market portfolio  $\theta_m$ , we see an interesting fact. Comparing  $\theta_m$  with  $\theta_{CML}$  learns that the asset allocations only differ a factor depending on  $\mu_p$ . This means that each portfolio on the CML is a linear combination of the market portfolio and the risk-free asset. We use this important property in the next section.

## 2.5.2 Optimal portfolio

Finding the optimal portfolio (that is the portfolio with the highest utility) for an investor means finding the best combination of the risk-free asset and the

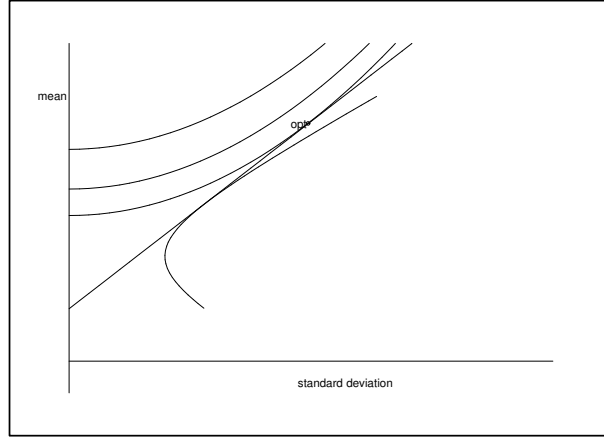

Figure 2.6: The optimal portfolio with risk-free asset

market portfolio. This is because we have seen that each portfolio on the CML (which is the efficient frontier) is a combination of the market portfolio and the risk-free asset. The next figure shows how the maximal utility curve is found. Suppose a proportion  $\Theta_f$  will be invested in the risk-free asset and a proportion of  $\Theta_m$  in the market portfolio. These are proportions, so  $\Theta_f + \Theta_m = 1$ . The portfolio return becomes

$$R_p = \Theta_f R_f + \Theta_m R_m$$

with

$$\begin{aligned} \text{var}(R_p) &= \Theta_f^2 \text{var}(R_f) + \Theta_m^2 \text{var}(R_m) + 2\Theta_f \Theta_m \text{cov}(R_f, R_m) \\ &= \Theta_m^2 \text{var}(R_m) \equiv \Theta_m^2 \sigma_m^2 \end{aligned}$$

because the variance of the return on the risk-free asset is zero, and the risk-free asset is uncorrelated with every risky portfolio. The utility function then is

$$E(C_0 + R_p) - \frac{1}{2}\gamma \text{var}(C_0 + R_p) = C_0 + \Theta_f R_f + \Theta_m \mu_m - \frac{1}{2}\gamma \Theta_m^2 \sigma_m^2$$

We want to maximize the utility function, so the optimization problem is

$$\text{Max} \left\{ C_0 + \Theta_f R_f + \Theta_m \mu_m - \frac{1}{2}\gamma \Theta_m^2 \sigma_m^2 \mid \Theta_f + \Theta_m = 1 \right\}$$

We solve this problem with Lagrange's method, which gives the following set of equations:

$$\begin{cases} \mu_m - \gamma \Theta_m \sigma_m^2 + \lambda = 0 \\ R_f + \lambda = 0 \\ \Theta_f + \Theta_m = 1 \end{cases} \quad (2.14)$$

First, we solve the second equation of (2.14) for  $\lambda$ :

$$\lambda = -R_f$$

Using this in the first equation of (2.14), and solving for  $\Theta_m$ , gives:

$$\Theta_m = \frac{\mu_m - R_f}{\gamma \sigma_m^2}$$



With the third equation of (2.14) we can solve  $\Theta_f$ :

$$\Theta_f = 1 - \frac{\mu_m - R_f}{\gamma\sigma_m^2}$$

If we use the results for the market portfolio ( $\mu_m$  and  $\sigma_m$ ), the fractions become:

$$\Theta_m = \frac{b - c\mu_f}{\gamma C_0} \quad \text{and} \quad \Theta_f = 1 - \frac{b - c\mu_f}{\gamma C_0}$$

These results are the proportions an investor should invest in the market portfolio and the risk-free asset to get maximal utility. The total amounts invested in the risky assets are

$$\Theta_m \theta_m = \frac{b - c\mu_f}{\gamma C_0} \frac{C_0}{b - c\mu_f} (\Sigma^{-1} \mu - \mu_f \Sigma^{-1} \bar{1}) = \frac{1}{\gamma} \Sigma^{-1} (\mu - \mu_f \bar{1})$$

and the total amount invested in the risk-free asset is

$$\Theta_f C_0 = \left(1 - \frac{b - c\mu_f}{\gamma C_0}\right) C_0 = C_0 - \frac{b - c\mu_f}{\gamma}$$

So the vector of the amounts the investor should invest in each individual asset is

$$\theta_{opt} \equiv \begin{pmatrix} \theta_1 \\ \vdots \\ \theta_N \\ \theta_f \end{pmatrix} = \begin{pmatrix} \frac{1}{\gamma} \Sigma^{-1} (\mu - \mu_f \bar{1}) \\ C_0 - \frac{b - c\mu_f}{\gamma} \end{pmatrix}$$

The corresponding portfolio mean and standard deviation can be calculated with  $\mu_{opt} = \mu^T \theta_{opt}$  and  $\sigma_{opt}^2 = \theta_{opt}^T \Sigma \theta_{opt}$ , so

$$\begin{aligned} \mu_{opt} &= \mu^T \frac{1}{\gamma} (\Sigma^{-1} \mu - \mu_f \Sigma^{-1} \bar{1}) + \mu_f \left( C_0 - \frac{b - c\mu_f}{\gamma} \right) \\ &= \frac{1}{\gamma} (c\mu_f^2 - 2b\mu_f + a) + \mu_f C_0 \equiv \frac{1}{\gamma} s^2 + \mu_f C_0 \end{aligned}$$

and

$$\begin{aligned} \sigma_{opt} &= \sqrt{\left( \frac{1}{\gamma} (\Sigma^{-1} \mu - \mu_f \Sigma^{-1} \bar{1}) \right)^T \Sigma \left( \frac{1}{\gamma} (\Sigma^{-1} \mu - \mu_f \Sigma^{-1} \bar{1}) \right) + 0} \\ &= \frac{1}{\gamma} \sqrt{c\mu_f^2 - 2b\mu_f + a} \equiv \frac{1}{\gamma} s \end{aligned}$$

## 2.6 Sensitivity analysis

In this section we describe what happens with the Markowitz portfolios when relevant parameters change. The relevant parameters in this section are the invested capital  $C_0$  and the parameter of risk aversion  $\gamma$ . When the risk-free asset is added we also look at the risk-free rate  $\mu_f$ . We will see how the optimal solution changes when these parameters become different. This can be done by differentiating the allocation formula with respect to the parameter.

**Minimum variance portfolio** If  $C_0$  is raised by one, the investment in each asset of the minimum variance portfolio is raised with the derivative, so with

$$\frac{\partial \theta_{mv}}{\partial C_0} = \frac{\partial \Sigma^{-1} \bar{1} \frac{C_0}{c}}{\partial C_0} = \Sigma^{-1} \bar{1} \frac{1}{c}$$

which is independent of the parameter  $C_0$ . So if  $C_0$  is multiplied with a factor  $x$ , the optimal solution also raises with factor  $x$ . In other words, it doesn't matter how much money an investor is able to invest, the proportions invested in each asset always stay the same. This can be verified by the fact that the invested fractions are given by

$$\frac{\theta_{mv}}{C_0} = \frac{\Sigma^{-1} \bar{1} \frac{C_0}{c}}{C_0} = \Sigma^{-1} \bar{1} \frac{1}{c}$$

which is independent of  $C_0$ .

**Tangency portfolio** Because in the allocation formula of the tangency portfolio the factor  $C_0$  is linearly present, we can conclude that also in this case, the portfolio fractions are independent of  $C_0$ . In other words, the tangency allocation and the invested capital  $C_0$  depend linearly on each other.

**Optimal portfolio** This linear relationship is not there when the optimal portfolio is looked at. We have seen in (2.11) that the optimal portfolio (without risk-free asset) is given by

$$\theta_{opt} = \frac{b}{C_0 \gamma} \theta_{tg} + \left(1 - \frac{b}{\gamma C_0}\right) \theta_{mv}$$

in terms of the minimum variance and tangency portfolio. We see that, if  $C_0$  is moving to infinity, the optimal portfolio is moving to the minimum variance portfolio. So if an investor has very much money to invest, he becomes more risk averse and invests a greater amount in the minimum variance portfolio. The proportion he invests in the tangency portfolio decreases, but stays the same in an absolute sense. If  $C_0 = \frac{b}{\gamma}$ , the situation is turned around and everything is invested in the tangency portfolio. A weird thing happens if an investor has very little money, so  $C_0$  is close to zero. To achieve maximum utility, the amount invested in the tangency portfolio goes high up to infinity (assuming  $b > 0$ ), and the amount invested in the minimum variance portfolio goes far down to minus infinity. This is not a realistic portfolio, so this optimal Markowitz portfolio doesn't seem usable for small values of  $C_0$ .

The same analysis holds for the parameter of risk aversion  $\gamma$ . For a very risk averse investor, so he has a high  $\gamma$ , the optimal policy is investing much in the minimum variance portfolio. If  $\gamma = \frac{b}{C_0}$ , he invests his money in the tangency portfolio. And if the investor is risk loving, which means he has a  $\gamma$  close to zero, the optimal portfolio becomes very long in the tangency, and very short in the minimum variance portfolio.

**Market portfolio** The allocation in market portfolio again is proportional to  $C_0$ , so the fractions invested in each asset are the same for all values for  $C_0$ .

Looking at the risk-free rate, we see that if  $\mu_f = 0$ , the market portfolio is identical to the tangency portfolio. If  $\mu_f$  raises to  $\frac{b}{c}$ , so the denominator goes

to zero, the optimal portfolio moves away from the tangency portfolio along the efficient frontier, and the allocation becomes

$$\lim_{\mu_f \rightarrow b/c} \frac{C_0}{b - c\mu_f} \Sigma^{-1}(\mu - \mu_f \bar{1}) = \lim_{x \rightarrow 0} \frac{b}{x} (\theta_{tg} - \theta_{mv})$$

so the allocation becomes proportional to  $\theta_{tg} - \theta_{mv}$ .

**Optimal portfolio with risk-free asset** By looking at the optimal allocation formula with risk-free asset, it is clear that the allocation of the risky part doesn't depend on  $C_0$ . The risk-free part does, so if  $C_0$  raises, the amount invested in the risk-free part raises, while the (absolute) amount invested in the risky assets stays identical (relatively it even decreases).

An investor with a high value for  $\gamma$  (so he is very risk averse), invests much in the risk-free asset, while when  $\gamma = \frac{b-c\mu_f}{C_0}$ , there is nothing invested in the risk-free part and everything in the risky part. So when the parameter of risk aversion has this value, the optimal portfolio is identical to the market portfolio. If  $\gamma$  is close to zero, the investor borrows much at the risk-free rate (it becomes very negative) and invests the borrowed money in the risky part.

## 2.7 Example

Throughout this thesis I will use an example to illustrate the previous findings.

### 2.7.1 Data

Suppose an investor has 1 euro to invest in some securities, so  $C_0 = 1$ . The results we will derive are then the fractions the investor invests in the different securities. He can choose to invest his single euro in seven securities from the Dutch AEX-index, the index of the 25 top securities in the Netherlands. These are Elsevier, Fortis, Getronics, Heineken, Philips, Shell (Royal Dutch) and Unilever. Together these seven securities contribute more than forty percent to the total AEX-index. The seven securities are chosen from seven different branches, the companies are respectively a publisher, bank, IT-company, brewer, electronics-, oil- and a food company.

The data I use are the daily returns downloaded from Bloomberg, covering the period from the 1st of January 1990 till the 31st of October the year I am writing this, in 2003. That makes more than thirteen years of daily data, in total 3609 daily observations per security.

With these results we can determine the vector of mean returns, and the covariance matrix of the daily returns. Because taking the log-returns makes the calculations a lot simpler (multiplying becomes adding), I will use the log-returns throughout this thesis. Whenever the word return is written, the log-return is mentioned. This does not change any of the derived results, it just makes things easier to work with. Further I will try to write down a maximum of three decimal places if it is possible. This gives the following table for expected returns:

It is clear that Heineken has the highest expected return over the analyzed period, while Getronics seems to be the worst asset to invest in. The three

$\times 10^{-3}$	$\mu_i$
Elsevier	0.266
Fortis	0.274
Getronics	0.162
Heineken	0.519
Philips	0.394
Royal Dutch	0.231
Unilever	0.277

Table 2.1: Expected daily returns

securities Elsevier, Fortis and Unilever do not differ much from each other. The covariances of the daily returns are

$\times 10^{-3}$	Els	For	Get	Hei	Phi	RDu	Uni
Elsevier	0.345	0.150	0.183	0.088	0.186	0.090	0.095
Fortis	0.150	0.399	0.204	0.107	0.236	0.130	0.127
Getronics	0.183	0.204	1.754	0.075	0.325	0.110	0.091
Heineken	0.088	0.107	0.075	0.243	0.096	0.064	0.086
Philips	0.186	0.236	0.325	0.096	0.734	0.147	0.114
Royal Dutch	0.090	0.130	0.110	0.064	0.147	0.221	0.093
Unilever	0.095	0.127	0.091	0.086	0.114	0.093	0.219

Table 2.2: Covariances of daily returns

The most striking fact from the covariance matrix is that Getronics has a very high variance (so a very high standard deviation). Also Philips' variance is quite higher than the other variances. Fortis seems to be highly correlated with the others (all correlations are greater than 0.1), and a look at the correlation matrix learns this is the case, while Heineken in general has much smaller covariances. Note that the correlation matrix is not given here, but correlations can be calculated by using the formula

$$\rho_{ij} = \frac{\sigma_{ij}}{\sigma_i \sigma_j}.$$

The risk-free investment is an investment in Dutch government bonds. This is not completely risk-free (the Dutch government can go bankrupt with very little chance), but it is a very stable investment compared to equities and therefore I will handle it as risk-free. Suppose the yearly return on this risk-free investment is 4%. Then the daily log-risk-free rate of return is given by

$$\mu_f = \frac{\log(1.04)}{250} = 0.157 \times 10^{-3}$$

where we assumed there are 250 trading days in a year.

The following figure shows the behavior of the seven indices during the time period we took, from the 1st of January 1990 till the 31st of October 2003. To compare the indices we have set the values at the starting date at index 100. The most interesting things to see are that Getronics has a very high peak (due to the technology bubble in '98 and '99), but also falls very low, and that Heineken en Philips seem to perform quite well over a long period. The remaining Elsevier, Fortis, Royal Dutch and Unilever are close to each other.

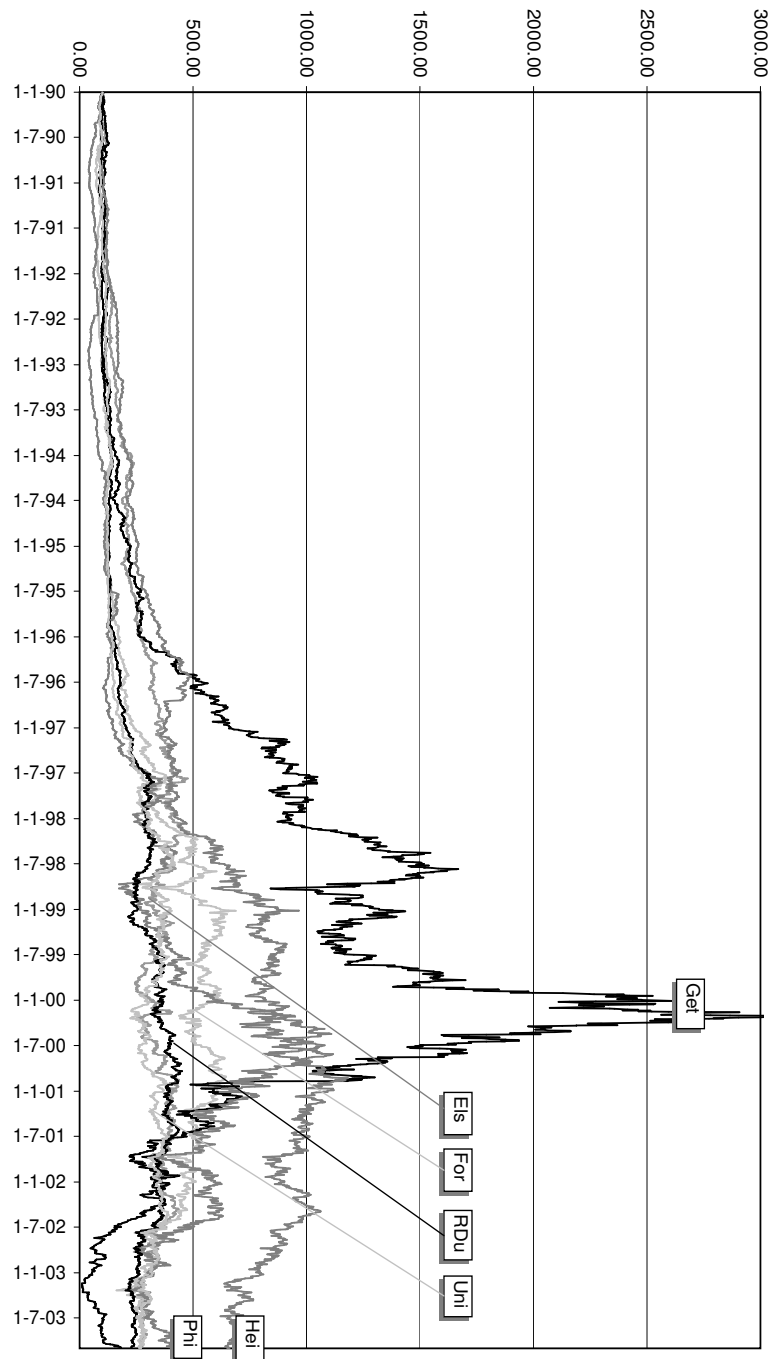

Figure 2.7: Overview of indexed returns of seven members of Dutch AEX-index

## 2.7.2 Calculations

With this data we can calculate portfolios of this chapter. We have

$$\begin{aligned} a &= \mu^T \Sigma^{-1} \mu = 1.213 \times 10^{-3} \\ b &= \mu^T \Sigma^{-1} \bar{1} = 2.639 \\ c &= \bar{1}^T \Sigma^{-1} \bar{1} = 8.044 \times 10^3 \\ d &= ac - b^2 = 2.791 \end{aligned}$$

The *efficient frontier* of our investment problem can simply be determined using these constants. It is given by

$$\sigma_p^2 = \frac{1}{d}(c\mu_p^2 - 2bC_0\mu_p + aC_0^2) = 2882.2\mu_p^2 - 1.891\mu_p + 0.435 \times 10^{-3}$$

This is equal to the hyperbola

$$\frac{\sigma_p^2}{0.124 \times 10^{-3}} - \frac{(\mu_p - 0.328 \times 10^{-3})^2}{43.13 \times 10^{-9}} = 1$$

The vector  $\theta_{EF}$ , the amounts invested in each asset when a portfolio is chosen on the efficient frontier, is given by

$$\theta_{EF} = \begin{pmatrix} 0.369 \\ 0.156 \\ 0.103 \\ -0.791 \\ -0.260 \\ 0.839 \\ 0.584 \end{pmatrix} + \mu_p \begin{pmatrix} -0.726 \\ -0.486 \\ -0.273 \\ 3.293 \\ 0.761 \\ -1.590 \\ -0.979 \end{pmatrix} \times 10^3$$

so the portfolio on the efficient frontier can be calculated for a desired portfolio mean. The portfolio with minimum variance, the *minimum variance* portfolio is given by

$$\begin{aligned} \mu_{mv} &= \frac{b}{c}C_0 = 0.328 \times 10^{-3} \\ \sigma_{mv} &= \frac{1}{\sqrt{c}}C_0 = 0.0111 \end{aligned}$$

and the corresponding investment policy is

$$\theta_{mv} = \Sigma^{-1} \bar{1} \frac{C_0}{c} = \begin{pmatrix} 0.131 \\ -0.003 \\ 0.013 \\ 0.290 \\ -0.011 \\ 0.317 \\ 0.263 \end{pmatrix}$$

We see that the most risk averse policy is investing the major part in Heineken, Royal Dutch and Unilever. This is explained by the fact that these three assets

have the lowest variance, as can be seen in the covariance matrix. In a similar way the values for the *tangency* portfolio can be determined. We get

$$\begin{aligned}\mu_{tg} &= \frac{a}{b}C_0 = 0.460 \times 10^{-3} \\ \sigma_{tg} &= \frac{\sqrt{a}}{b}C_0 = 0.0132 \\ \theta_{tg} &= \Sigma^{-1}\mu\frac{C_0}{b} = \begin{pmatrix} 0.036 \\ -0.067 \\ -0.022 \\ 0.723 \\ 0.089 \\ 0.108 \\ 0.134 \end{pmatrix}\end{aligned}$$

So the tangency portfolio, or the portfolio with maximum Sharpe ratio, consists for more than seventy percent of Heineken. This is because Heineken has by far the highest ratio mean/variance. Suppose the parameter of risk aversion for our investor is  $\gamma = 2$ , so the utility function becomes

$$u = E(R_p) - \frac{2}{2}var(R_p)$$

The optimal, utility maximizing, Markowitz portfolio then is given by

$$\theta_{opt} = \frac{1}{\gamma}\Sigma^{-1}\left(\mu + \bar{1}\left(\frac{\gamma C_0 - b}{c}\right)\right) = \begin{pmatrix} 0.005 \\ -0.088 \\ -0.034 \\ 0.861 \\ 0.121 \\ 0.041 \\ 0.093 \end{pmatrix}$$

with  $\mu_{opt} = 0.502 \times 10^{-3}$ ,  $\sigma_{opt} = 0.0145$ . If the investor becomes more risk averse, for example the parameter of risk aversion raises to  $\gamma = 10$ , we see that the optimal Markowitz portfolio is moving closer towards the minimum variance portfolio:

$$\theta_{opt} = \begin{pmatrix} 0.106 \\ -0.020 \\ 0.004 \\ 0.404 \\ 0.016 \\ 0.262 \\ 0.229 \end{pmatrix}$$

with  $\mu_{opt} = 0.363 \times 10^{-3}$  and  $\sigma_{opt} = 0.0113$ . So in order to lower the risk, the investor decreases the amount invested in Heineken and increases the amounts invested in all the other securities.

Suppose the risk-free rate  $\mu_f$  of Dutch government bonds is added. We can determine the capital market line, which is the new efficient frontier:

$$\mu_p = \left(\sqrt{c\mu_f^2 - 2b\mu_f + a}\right)\sigma_p + C_0\mu_f = 0.0241\sigma_p + 0.157 \times 10^{-3}$$

The *market portfolio* is given by

$$\begin{aligned}\mu_m &= \frac{a - b\mu_f}{b - c\mu_f} C_0 = 0.580 \times 10^{-3} \\ \sigma_m &= \frac{\sqrt{c\mu_f^2 - 2b\mu_f + a}}{b - c\mu_f} C_0 = 0.0175 \\ \theta_m &= \Sigma^{-1} (\mu - \mu_f \bar{1}) \frac{C_0}{b - c\mu_f} = \begin{pmatrix} -0.052 \\ -0.126 \\ -0.055 \\ 1.119 \\ 0.181 \\ -0.084 \\ -0.016 \end{pmatrix}\end{aligned}$$

We see that the market portfolio largely consists of Heineken. This means that if there is a risk-free asset, every investor will invest in a combination of Heineken and the risk-free asset (and very little of the other assets).

The optimal portfolio when the risk-free asset is available can also be calculated. Assume again the parameter of risk aversion is  $\gamma = 2$ . Then

$$\theta_{opt} = \begin{pmatrix} \frac{\frac{1}{\gamma} \Sigma^{-1} (\mu - \mu_f \bar{1})}{C_0 - \frac{b - c\mu_f}{\gamma}} \end{pmatrix} = \begin{pmatrix} -0.036 \\ -0.087 \\ -0.038 \\ 0.771 \\ 0.125 \\ -0.058 \\ 0.011 \\ 0.311 \end{pmatrix}$$

so the investor is investing 31 percent in the risk-free asset. The corresponding portfolio mean and standard deviation are  $\mu_{opt} = 0.448 \times 10^{-3}$  and  $\sigma_{opt} = 0.0121$ . If the investor is more risk averse, for example  $\gamma = 10$ , we have the following optimal investment policy:

$$\theta_{opt} = \begin{pmatrix} -0.007 \\ -0.017 \\ -0.008 \\ 0.154 \\ 0.025 \\ -0.012 \\ 0.002 \\ 0.862 \end{pmatrix}$$

with  $\mu_{opt} = 0.215 \times 10^{-3}$  and  $\sigma_{opt} = 0.0024$ , and it is clear that the more risk averse investor invests more in the risk-free asset and less in the risky assets.

We can draw the points found in a diagram, which looks like the following. In the figure we see the efficient frontier (EF), the capital market line (CML) and the tangency line (TG). There are also two utility curves, with parameters of risk aversion  $\gamma = 1$  and  $\gamma = 10$ . The indicated points are the minimum variance portfolio (mv), tangency portfolio (tg), market portfolio (m) and risk-free rate (rf). We also see two optimal portfolios belonging to the two utility curves.



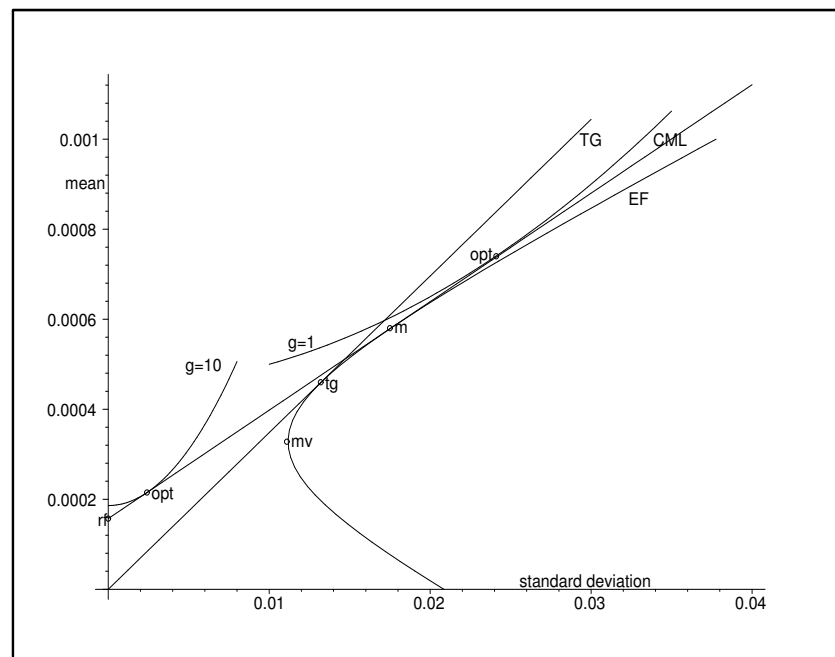

Figure 2.8: Graphical view of the portfolios of the example

## 2.8 References

- Aït-Sahalia, Brandt [2001] "Variable Selection for Portfolio Choice" *Journal of Finance* no.4
- Blake [1990] *Financial Market Analysis*
- Campbell, Lo, MacKinlay [1997] *The Econometrics of Financial Markets*
- Copeland, Weston [1983] *Financial Theory and Corporate Policy*
- Elton, Gruber [1981] *Modern Portfolio Theory and Investment Analysis*
- Markowitz [1952] "Portfolio Selection" *Journal of Finance* no.7
- Rudolf [1994] *Algorithms for Portfolio Optimization and Portfolio Insurance*

---

## Another approach for risk: Safety first

---

So far, we have discussed the portfolio optimization in a mean-standard deviation framework. We said risk can be measured by standard deviation. There is some criticism against this approach. The main argument against this is that standard deviation is a measurement for volatility. A portfolio with a high standard deviation has a high volatility, but this is both upside and downside. Some people are only interested in the chance of a downside risk, so another model had to be made. One of these models, which are concerned with the downside risk, is the *safety first* principle.

This chapter first gives an overview of some safety first models. The second section solves one particular safety first criterion, the Telser model. The third section adds a risk-free asset and in section 4 the example of the previous chapter is continued. The last section contains the references.

### 3.1 Safety first models

There are three basic safety first models. These models are made in the fifties and sixties and are developed by Roy, Kataoka and Telser. They all handle with a limit capital  $C_L$ . This is a lower bound for the amount of capital at the end of the period  $C_{end}$ .

**Roy** Roy predetermines the limit capital. He wants to minimize the chance that the capital at the end of the period gets lower than the limit capital. so

$$\text{Min} \{P(C_{end} \leq C_L)\}$$

**Kataoka** Kataoka takes another approach. He chooses a value  $\alpha$ , called the shortfall probability. He wants to maximize the lower limit capital  $C_L$  such that the chance that the end-capital gets lower than the limit capital will be  $\alpha$  or less:

$$\text{Max} \{ C_L \mid P(C_{end} \leq C_L) \leq \alpha \}$$

**Telser** The third safety first approach is from Telser. He predetermines the shortfall probability  $\alpha$ , but he also chooses the limit capital  $C_L$ . Telser wants to maximize the expected capital at the end of the period given these shortfall probability and limit capital:

$$\text{Max} \{ E(C_{end}) \mid P(C_{end} \leq C_L) \leq \alpha \}$$

In the further sections we will continue with the Telser approach, because this approach is most relevant for Rabobank. Rabobank has a fixed rating, which means that there is a fixed shortfall probability  $\alpha$ . At the moment, the rating for Rabobank is AAA, which means that the probability of getting in default is less than 0,01% at a yearly basis. The limit capital  $C_L$  then is the amount of capital an investor has when he gets in default, so  $C_L = 0$ . We see that for Rabobank both  $\alpha$  and  $C_L$  are fixed, so it is most useful to use Telsers criterion. Furthermore, the Telser criterion is intuitively the most logical way of choosing the optimal portfolio. This is because the intention of most investors is simply to maximize returns, and the Telser criterion is the one that has this basic principle.

## 3.2 Telsers criterion

This section formulates and solves the optimal portfolio when the Telser criterion is used. Both an intuitive and an analytical solution are provided.

### 3.2.1 Formulation

When we take on Telsers approach, we maximize expected return subject to the constraint that the shortfall probability is  $\alpha$  or less. The shortfall probability is the chance that the investor loses all his invested money, so when  $C_{end} \leq 0$ . In formula, this becomes

$$\text{Max} \{ E(C_0 + R_p) \mid P(C_0 + R_p \leq 0) \leq \alpha \}.$$

If we use that  $E(C_0 + R_p) = E(C_0) + E(R_p) = C_0 + \mu_p$  and if we add the necessary constraints that the sum of the  $\theta_i, i = 1, \dots, N$  must be equal to the start capital, and that  $\mu_p = \mu^T \theta$ , then the set of equations becomes

$$\text{Max} \left\{ \mu_p \mid \begin{array}{l} P(R_p \leq -C_0) \leq \alpha \\ \bar{1}^T \theta = C_0 \\ \mu_p = \mu^T \theta \end{array} \right\}. \quad (3.1)$$

Right now we make an important assumption. To say something about the shortfall constraint, we assume that the returns are *normally distributed*. This means that we assume that

$$P(R_p \leq X) = \frac{1}{\sqrt{2\pi}} \int_{-\infty}^k e^{-\frac{1}{2}t^2} dt \equiv \Phi(k) \quad \text{with} \quad k = \frac{X - \mu_p}{\sigma_p}$$

With this assumption we can simplify the constraint  $P(R_p \leq -C_0) \leq \alpha$ . This becomes

$$\Phi\left(\frac{-C_0 - \mu_p}{\sigma_p}\right) \leq \alpha \quad \Rightarrow \quad \frac{-C_0 - \mu_p}{\sigma_p} \leq k_\alpha$$

$$\mu_p \geq -C_0 - k_\alpha \sigma_p.$$

which is the upper half of the line through  $(0, -C_0)$  with slope  $-k_\alpha$ . This is the *shortfall line*. In this formula  $k_\alpha$  is the quantile of the standard normal distribution with probability  $\alpha$ . For example, when  $\alpha = 0.01$  the corresponding quantile is  $k_\alpha = -2.33$ . Note that  $k_\alpha$  is negative for all  $\alpha \leq 0.5$ , so the slope of the shortfall line is positive.

When changing the shortfall constraint into a constraint with parameters  $\mu_p$  and  $\sigma_p$  for the portfolio mean respectively the portfolio standard deviation, we have to add the constraint for the standard deviation (variance)  $\sigma_p^2 = \theta^T \Sigma \theta$ , so system (3.1) becomes

$$\text{Max} \left\{ \mu_p \left| \begin{array}{l} \mu_p \geq -C_0 - k_\alpha \sigma_p \\ \bar{1}^T \theta = C_0 \\ \mu_p = \mu^T \theta \\ \sigma_p^2 = \theta^T \Sigma \theta \end{array} \right. \right\}. \quad (3.2)$$

### 3.2.2 Intuitive solution

Let's first solve this system intuitively. The last three constraints give the set of efficient portfolios, all possible combinations of risky assets when total amount  $C_0$  is spent. In a figure (mean-standard deviation space) this is the area on the "inside" of the efficient frontier. The first constraint of (3.2) gives the area below the line  $\mu_p = -C_0 - k_\alpha \sigma_p$ . All constraints together give the area  $A$  in the figure. The goal of (3.2) is to maximize the expected return, so we have to find the maximum value of  $\mu_p$  in area  $A$ . It is clear that this is the case in point  $T$ , which is the intersection point of the efficient frontier and the shortfall line.

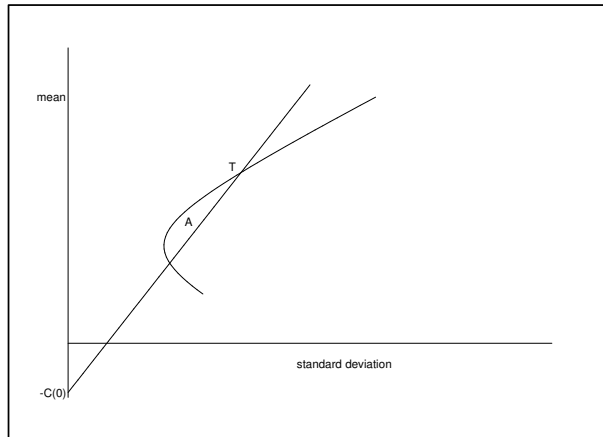

Figure 3.1: The feasible area  $A$  and the optimal Telser point

The intersection point  $T$  can easily be calculated, using the formulas for the efficient frontier and the shortfall line:

$$\sigma_p^2 = \frac{1}{d}(c\mu_p^2 - 2bC_0\mu_p + aC_0^2) \quad \text{and} \quad \sigma_p^2 = \left( \frac{-C_0 - \mu_p}{k_\alpha} \right)^2$$

Calculating the intersection point means equalizing both formulas and solving for  $\mu_p$ , which gives

$$\frac{1}{d}(c\mu_p^2 - 2bC_0\mu_p + aC_0^2) = \left( \frac{-C_0 - \mu_p}{k_\alpha} \right)^2$$

This equation is solved in appendix A. It results in

$$\mu_T = \frac{bk_\alpha^2 + d + \sqrt{dk_\alpha^2(a + 2b + c - k_\alpha^2)}}{ck_\alpha^2 - d} C_0 \quad (3.3)$$

So the variance can be calculated:

$$\sigma_T = \left( \frac{-C_0 - \mu_T}{k_\alpha} \right) = \frac{(c + b)k_\alpha^2 + \sqrt{dk_\alpha^2(a + 2b + c - k_\alpha^2)}}{(d - ck_\alpha^2)k_\alpha} C_0$$

The vector  $\theta_T$ , the amounts invested in each individual asset in the Telser optimal point, can be calculated by using the formula in the previous chapter for portfolios on the efficient frontier

$$\theta_T = \frac{1}{d} \Sigma^{-1} ((a\bar{1} - b\mu)C_0 + (c\mu - b\bar{1})\mu_T)$$

and filling in the value for  $\mu_T$ , which gives a large expression that is not useful to write down here.

### 3.2.3 Analytical solution

After this intuitive approach I will use a more mathematical analysis to check the above results of (3.2). Because the calculations can be quite heavy, they can be found in appendix B at the end of this thesis. After reading this appendix, we can conclude that the results of this more analytical approach are identical to the results above.

## 3.3 With risk-free asset

If we add a risk-free asset, the efficient frontier changes in the CML, the line that shows linear combinations of the risk-free asset and the market portfolio. Again, we first solve this problem intuitively, and then discuss the analytical solution.

### 3.3.1 Intuitive solution

Solving the system (3.1) means finding the maximum value for  $\mu_p$  in the area below the CML and above the shortfall line. This maximum value is the intersection point of the shortfall line with the CML, as can be seen in the next figure.

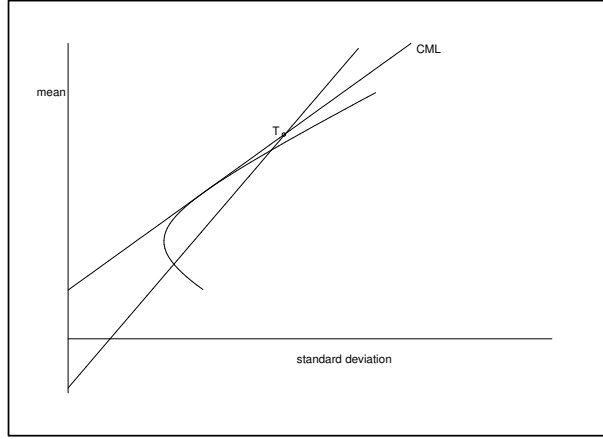

Figure 3.2: The optimal Telser portfolio with risk-free asset

To calculate this point of intersection, we equalize the formulas of both lines, so

$$\begin{aligned} \left(\sqrt{c\mu_f^2 - 2b\mu_f + a}\right) \sigma_p + C_0\mu_f &= -C_0 - k_\alpha\sigma_p \\ \sigma_T &= \frac{-1 - \mu_f}{k_\alpha + \sqrt{c\mu_f^2 - 2b\mu_f + a}} C_0 \equiv \frac{-1 - \mu_f}{s + k_\alpha} C_0 \end{aligned}$$

where we defined  $s \equiv \sqrt{c\mu_f^2 - 2b\mu_f + a}$ , the slope of the CML. The corresponding mean can be found by using the formula of one of both lines. Here the shortfall line is used:

$$\mu_T = -C_0 - k_\alpha\sigma_p = -C_0 - k_\alpha \frac{-1 - \mu_f}{s + k_\alpha} C_0 = \frac{\mu_f k_\alpha - s}{s + k_\alpha} C_0$$

Now we want to calculate the corresponding values for  $\theta$ . Because we are not on the efficient frontier (like the situation without a risk-free asset) we can not use the same formula. Remember that every portfolio on the CML is a linear combination of the market portfolio and the risk-free asset. Suppose we invest a proportion  $\Theta_m$  in the market portfolio and a proportion  $\Theta_f$  in the risk-free asset. Because the variance in the portfolio return of the risk-free asset is zero (there is no risk) and the covariance between the risk-free asset and the market portfolio is zero (they are uncorrelated), we know that

$$\mu_T = \Theta_m\mu_m + \Theta_f C_0\mu_f \quad \text{and} \quad \sigma_T = \Theta_m\sigma_m \quad (3.4)$$

like we have seen in the previous chapter. The  $\mu_m$  and  $\sigma_m$  are the mean and standard deviation of the market portfolio. Expressions of these are found in the previous chapter. From (3.4) we see that

$$\Theta_m = \frac{\sigma_T}{\sigma_m}$$

Since we have expressions for both  $\sigma_T$  and  $\sigma_m$ , we can calculate this fraction. The result is:

$$\Theta_m = \frac{(1 + \mu_f)(c\mu_f - b)}{s(s + k_\alpha)}$$

If we use the other equation of (3.4), we can calculate the proportion invested in the risk-free asset:

$$\Theta_f = \frac{\mu_T - \Theta_m \mu_m}{C_0 \mu_f}$$

We have expressions for  $\mu_T$ ,  $\Theta_m$  and  $\mu_m$ , so we can calculate this proportion. We give the result:

$$\Theta_f = \frac{a + b - (b + c)\mu_f + k_\alpha s}{s(s + k_\alpha)}$$

We can check the results by adding the two proportions, which results in

$$\Theta_m + \Theta_f = \frac{(1 + \mu_f)(c\mu_f - b) + a + b - (b + c)\mu_f + k_\alpha s}{s(s + k_\alpha)} = 1$$

so the total proportion is one, which should be the case. Then the total amounts invested in each portfolio are

$$\theta_T \equiv \begin{pmatrix} \theta_1 \\ \vdots \\ \theta_N \\ \theta_f \end{pmatrix} = \begin{pmatrix} \Theta_m \theta_m \\ \Theta_f C_0 \end{pmatrix} = \begin{pmatrix} \frac{1 + \mu_f}{s(s + k_\alpha)} \Sigma^{-1} (\mu_f \bar{1} - \mu) C_0 \\ \frac{a + b - (b + c)\mu_f + k_\alpha s}{s(s + k_\alpha)} C_0 \end{pmatrix} \quad (3.5)$$

### 3.3.2 Analytical solution

Also when adding a risk-free asset, we can use a more analytical approach in solving the problem and getting the results derived above. See appendix B for the detailed results.

## 3.4 Example

We can look at the example of section 2.7 and see what happens if we take the optimal Telser portfolio. Suppose the portfolio returns are normally distributed with means and variances as in section 2.7. Remember these are daily returns, which is not what we need in this chapter. We need yearly returns, because in general the probability of default is given at a yearly basis, and not at a daily basis. That is why we transform the mean and covariance matrix to a yearly basis, by multiplying them by 250 (this is allowed because the returns are the log-returns). Then the means, standard deviations and correlations are given by the next table. A percentage notation is used for a better interpretation of the data.

With this data the two necessary parameters, the mean vector  $\mu$  and the covariance matrix  $\Sigma$ , can be determined. They are in the next table.

We have to set a probability of default  $\alpha$ . As mentioned before, Rabobank has a AAA rating. This means that the probability that the bank goes in default is less than 0.01% per year. In other words, the chance that this happens is less than once in a ten-thousand years. So

$$\alpha = 0.0001$$

Suppose that the yearly portfolio return is normally distributed with means and covariances as above. This is an important assumption we make, because

	mean (%)	st.dev. (%)	correlations $\rho_{ij}$ (%)						
			Els	For	Get	Hei	Phi	RDu	Uni
Els	7	29	100	41	24	30	37	33	35
For	7	32	41	100	24	35	44	44	43
Get	4	66	24	24	100	12	29	18	15
Hei	13	25	30	35	12	100	23	27	37
Phi	10	43	37	44	29	23	100	36	28
RDu	6	23	33	44	18	27	36	100	42
Uni	7	23	35	43	15	37	28	42	100

Table 3.1: Yearly means, standard deviations and correlations

$\mu$	$\Sigma$							$\times 10^{-3}$
66.52	86.22	37.62	45.73	21.99	46.59	22.62	23.75	
68.47	37.62	99.65	50.98	26.84	59.10	32.51	31.74	
40.40	45.73	50.98	438.40	18.77	81.14	27.53	22.63	
129.69	21.99	26.84	18.77	60.64	23.96	15.91	21.60	
98.58	46.59	59.10	81.14	23.96	183.51	36.63	28.47	
57.69	22.62	32.51	27.53	15.91	36.63	55.22	23.35	
69.23	23.75	31.74	22.63	21.60	28.47	23.35	54.86	

Table 3.2:  $\mu$  and  $\Sigma$  of yearly returns ( $\times 10^{-3}$ )

in reality it is absolutely not known which distribution belongs to the yearly returns. There are too little data, and the yearly range is too long to estimate this. But if returns are normally distributed, then

$$k_\alpha = k_{0.0001} = -3.719,$$

the quantile of the normal distribution. The corresponding Telser portfolio has mean

$$\mu_T = \frac{bk_\alpha^2 + d + \sqrt{dk_\alpha^2(a + 2b + c - k_\alpha^2)}}{ck_\alpha^2 - d} C_0 = 0.158$$

and standard deviation

$$\sigma_T = \frac{(c + b)k_\alpha^2 + \sqrt{dk_\alpha^2(a + 2b + c - k_\alpha^2)}}{(d - ck_\alpha^2)k_\alpha} C_0 = 0.311$$

The optimal allocation is

$$\theta_T = \frac{1}{d} \Sigma^{-1} ((a\bar{1} - b\mu)C_0 + (c\mu - b\bar{1})\mu_T) = \begin{pmatrix} -0.088 \\ -0.150 \\ -0.069 \\ 1.285 \\ 0.219 \\ -0.164 \\ -0.033 \end{pmatrix}$$

This looks very much like the market portfolio. So it seems that, if the yearly portfolio return is assumed normally distributed, the optimal Telser portfolio comes close to the market portfolio, where almost everything is invested in



Heineken. If we compare this with the optimal Markowitz portfolio, we see that the optimal Telser portfolio is almost similar to the optimal Markowitz portfolio with parameter of risk aversion  $\gamma = 2$ . It can be calculated that an investor with parameter  $\gamma = 2.20$  has the same preferences in the Markowitz approach as in the Telser approach.

If we add the risk-free asset with  $\mu_f = \log(1.04) = 0.0392$  (remember we are working in a yearly context now), we get the following optimal allocation:

$$\theta_T = \begin{pmatrix} \frac{1+\mu_f}{s(s+k_\alpha)} \Sigma^{-1} (\mu_f \bar{1} - \mu) C_0 \\ \frac{a+b-(b+c)\mu_f+k_\alpha s}{s(s+k_\alpha)} C_0 \end{pmatrix} = \begin{pmatrix} -0.058 \\ -0.141 \\ -0.062 \\ 1.258 \\ 0.203 \\ -0.094 \\ 0.018 \\ -0.124 \end{pmatrix}$$

with  $\mu_T = 0.158$  and  $\sigma_T = 0.311$ . So with the addition of the risk-free asset, we still are doing well to invest much in Heineken. Because we invest a negative amount in the risk-free asset, we borrow money to finance the investments in the risky securities. But it is not very much we are borrowing at the risk-free rate, so the optimal Telser portfolio with risk-free asset doesn't differ much from the optimal portfolio without risk-free asset.

The figure below shows the Telser portfolio in a graphical view. The efficient frontier (EF), capital market line (CML) and shortfall line (SL) are drawn.

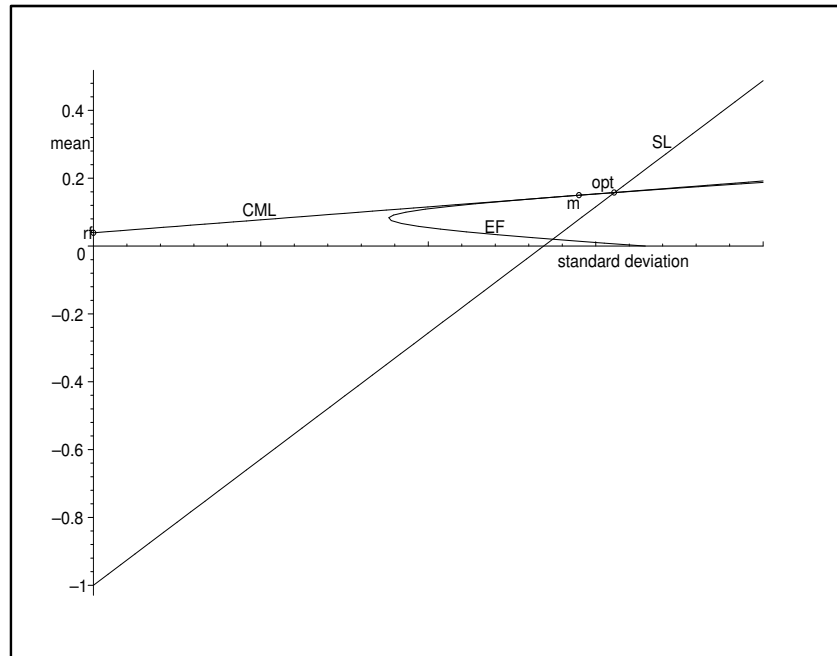

Figure 3.3: Graphical view of the Telser portfolio of this example

## 3.5 References

Elton, Gruber [1981] *Modern Portfolio Theory and Investment Analysis*

Kataoka [1963] "A Stochastic Programming Model" *Econometrica* 31

Roy [1952] "Safety-first and the Holding of Assets" *Econometrica* 20

Telser [1955] "Safety-first and Hedging" *Review of Economic Studies* 23



---

# Elliptical distributions

---

Up to now, we have assumed that asset returns are normally distributed. This made mean-variance analysis straightforward, because the shortfall probability is completely determined by its mean and variance. Unfortunately, it is not realistic to assume that portfolio returns are normally distributed. It appears that in reality the distribution of asset returns has fatter tails, so an unusual return does more often happen in reality than when the normal distribution is used for modelling. In this chapter I will introduce a set of distributions, the *elliptical distributions*, that covers the asset returns more realistic than the normal distribution.

The first section formulates the properties of an elliptical distribution. Some examples of elliptical distributions are shown in section 2. Section 3 gives a proof that mean-variance analysis also holds for all elliptical distributions, and this is used in section 4 where the Telser optimal portfolios are recalculated for elliptically distributed returns. Sections 5 and 6 are for the example and references.

## 4.1 Introduction

Consider a  $n$ -dimensional vector  $X = (X_1, X_2, \dots, X_n)^T$ . If  $X$  is elliptical distributed, it has by definition the following density function

$$f_X(x) = c_n |\Omega|^{-1/2} g_n \left[ \frac{1}{2} (x - \mu)^T \Omega^{-1} (x - \mu) \right] \quad (4.1)$$

for some column vector  $\mu$ , positive definite  $(n \times n)$ -matrix  $\Omega$  and for some function  $g_n(\cdot)$  called the *density generator*.  $|\cdot|$  means taking the determinant. If the density generator doesn't depend on  $n$ , which is often the case, we simply

write  $g(\cdot)$ . The condition

$$\int_0^\infty x^{n/2-1} g_n(x) dx < \infty$$

guarantees  $g_n(x)$  to be a density generator (see Landsman and Valdez (2002)). By noticing that the total density must be one, the constant  $c_n$  can be calculated. This gives

$$c_n = \frac{\Gamma(n/2)}{(2\pi)^{n/2}} \left[ \int_0^\infty x^{n/2-1} g_n(x) dx \right]^{-1} \quad (4.2)$$

which is shown by Landsman and Valdez (2002).  $\Gamma(\cdot)$  represents the gamma function.

The characteristic function of the elliptical distributed  $X$  has the form

$$\phi_X(t) \equiv E(e^{it^T X}) = e^{it^T \mu} \psi\left(\frac{1}{2} t^T \Omega t\right) \quad (4.3)$$

for some column vector  $\mu$ , positive definite  $(n \times n)$ -matrix  $\Omega$  and some function  $\psi(t)$ . The latter function is called the *characteristic generator*. If the  $n$ -dimensional vector  $X$  is elliptical distributed we write  $X \sim E_n(\mu, \Omega, \psi)$ . We can also determine the elliptical distribution by the density generator  $g_n$  and write  $X \sim E_n(\mu, \Omega, g_n)$ , which is the notation I will use this chapter.

The family of elliptical distributions has some interesting properties. For proofs of the properties I refer to the article of Landsman and Valdez (2002). If

$$\int_0^\infty g_1(x) dx < \infty$$

the mean of vector  $X$  exists (so this is not always the case). The mean then is  $E(X) = \mu$ . In addition, if

$$|\psi'(0)| < \infty$$

the covariance matrix exists and is equal to  $Cov(X) = -\psi'(0)\Omega$ , so if the characteristic generator can be chosen such that  $\psi'(0) = -1$ , then the covariance matrix equals  $\Omega$ . Because, with this notation,  $\Omega$  does not necessarily have to be the covariance matrix (but is proportional to covariance matrix), we do not write it as  $\Sigma$ . We refer to  $\Omega$  as the dispersion matrix.

Another property of the elliptical distributions is that if  $X \sim E_n(\mu, \Omega, g_n)$ , then for some  $(m \times n)$ -matrix  $A$  and some  $m$ -dimensional column vector  $B$  we have that

$$AX + B \sim E_m(A\mu + b, A\Omega A^T, g_m) \quad (4.4)$$

So any linear combination of elliptical distributions is another elliptical distribution, with the same density generator function.

It follows that the marginal distribution of any component of  $X$  is also elliptically distributed with the same characteristic generator. If  $X$  has an elliptical distribution, so  $X = (X_1, X_2, \dots, X_n)^T \sim E_n(\mu, \Omega, g_n)$ , then the marginal distributions are distributed by  $X_k \sim E_1(\mu_k, \omega_k^2, g_1)$  for  $k = 1, 2, \dots, n$ , where  $\omega_k^2$  is the  $k$ 'th element of the diagonal of  $\Omega$ . This means that the marginal densities can be written as

$$f_{X_k}(x) = \frac{c_1}{\omega_k} g_1 \left[ \frac{1}{2} \left( \frac{x - \mu_k}{\omega_k} \right)^2 \right] \quad (4.5)$$

If we define the sum  $X_{sum} = X_1 + X_2 + \dots + X_n = \bar{1}^T X$ , then by using (4.4) it follows that

$$X_{sum} \sim E_1(\bar{1}^T \mu, \bar{1}^T \Omega \bar{1}, g_1)$$

and in a similar way it is clear that the weighted sum  $X_{weighted} = \theta_1 X_1 + \theta_2 X_2 + \dots + \theta_n X_n = \theta^T X$  is distributed by

$$X_{weighted} \sim E_1(\theta^T \mu, \theta^T \Omega \theta, g_1)$$

## 4.2 Some examples of elliptical distributions

Let's look at some well known families of the elliptical distributions. The examples are presented concise, a more detailed approach can be found in the article by Landsman and Valdez (2002).

We will discuss the normal, student-t, Laplace and Logistic family of elliptical distributions in this section. The last subsection compares the different elliptical distributions with each other.

### 4.2.1 Normal family

The most familiar example of an elliptical distribution is the normal family. If we take for the elliptical vector  $X$  the density generator

$$g(u) = e^{-u}$$

which doesn't depend on  $n$ , we get the normal distribution. To show this, we calculate  $c_n$  with formula (4.2). We get  $c_n = (2\pi)^{-n/2}$ . If we use (4.5) and the value of  $c_1$ , it follows that the marginal density function of  $X_k$  is given by

$$f_{X_k}(x) = \frac{1}{\sqrt{2\pi\omega_k}} e^{-\frac{1}{2}\left(\frac{x-\mu_k}{\omega_k}\right)^2}$$

which is the normal distribution. So  $X_k \sim N(\mu_k, \omega_k^2)$ . The multivariate density of the vector  $X$  is given by formula (4.1), which gives

$$f_X(x) = \frac{1}{(2\pi)^{n/2}} |\Omega|^{-1/2} \exp\left[-\frac{1}{2}(x - \mu)^T \Omega^{-1}(x - \mu)\right],$$

the multivariate normal density function. So a normally distributed vector is a special case of an elliptical distributed vector. It is well known that  $E(X) = \mu$  and  $Cov(X) \equiv \Sigma = \Omega$ . It follows that  $\sigma_k = \omega_k$ .

The next figures are the marginal standard normal density function and the bivariate standard normal case, so  $\mu = 0$  and  $\Omega = I$ , the identity matrix.

### 4.2.2 Student-t family

For the density generator

$$g_n(u) = \left(1 + \frac{2u}{\nu}\right)^{-(n+\nu)/2}$$

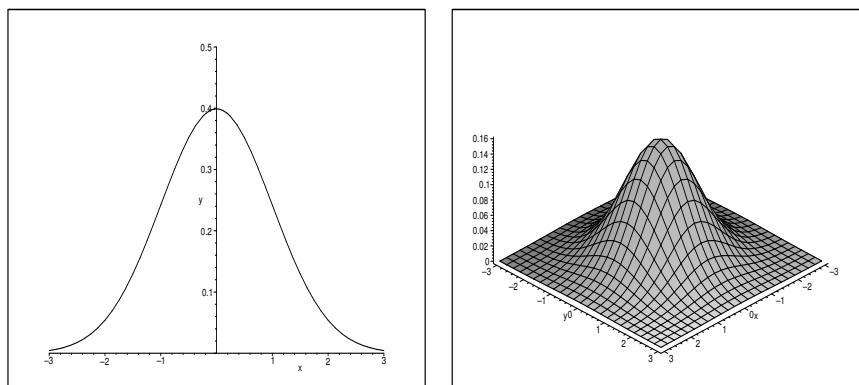

Figure 4.1: Marginal and bivariate standard normal density function

the elliptical vector  $X$  has a multivariate student-t distribution with  $\nu$  degrees of freedom. Using (4.2) it can be shown that

$$c_n = \frac{\Gamma((n + \nu)/2)}{\Gamma(\nu/2)(\pi\nu)^{n/2}}$$

so the multivariate distribution is, using (4.1),

$$f_X(x) = \frac{\Gamma((n + \nu)/2)}{\Gamma(\nu/2)(\pi\nu)^{n/2}|\Omega|^{1/2}} \left[ 1 + \frac{1}{\nu}(x - \mu)^T \Omega^{-1}(x - \mu) \right]^{-(n+\nu)/2}$$

If we take  $n = 1$  we get the marginal density function of  $X_k, k = 1 \dots n$ , which results in

$$f_{X_k}(x) = \frac{\Gamma((\nu + 1)/2)}{\Gamma(\nu/2)\sqrt{\pi\nu}} \left[ 1 + \frac{1}{\nu}x^2 \right]^{-(\nu+1)/2}$$

In this formula we took  $\omega_k = 1$  and  $\mu_k = 0$ . We see that this is the well known density function of the student-t distribution with  $\nu$  degrees of freedom. The dispersion  $\omega$  doesn't equal the standard deviation, but as mentioned before there is a linear relationship. It is shown that this relationship is given by  $Var(X_k) \equiv \sigma_k^2 = \frac{\nu}{\nu-2}\omega_k^2$  for a t-distributed variable with  $\nu$  degrees of freedom. If we take  $\nu = 1$  we get the *Cauchy distribution*. For  $\nu \rightarrow \infty$  we get the (standard) normal distribution. The graphs below give the marginal density functions for some  $\nu$  and the bivariate case for  $\nu = 1$

### 4.2.3 Laplace family

Another example of an elliptical distribution is the Laplace or Double Exponential distribution. This distribution is obtained by taking

$$g(u) = e^{-\sqrt{2u}}$$

as the density generator. Again we can calculate  $c_n$  by using (4.2), which gives (for a change I give the complete calculation)

$$c_n = \frac{\Gamma(n/2)}{(2\pi)^{n/2}} \left[ \int_0^\infty x^{n/2-1} e^{-\sqrt{2x}} dx \right]^{-1} = \frac{\Gamma(n/2)}{(2\pi)^{n/2}} \left[ \int_0^\infty y^{n-2} e^{-y\sqrt{2}} 2y dy \right]^{-1}$$

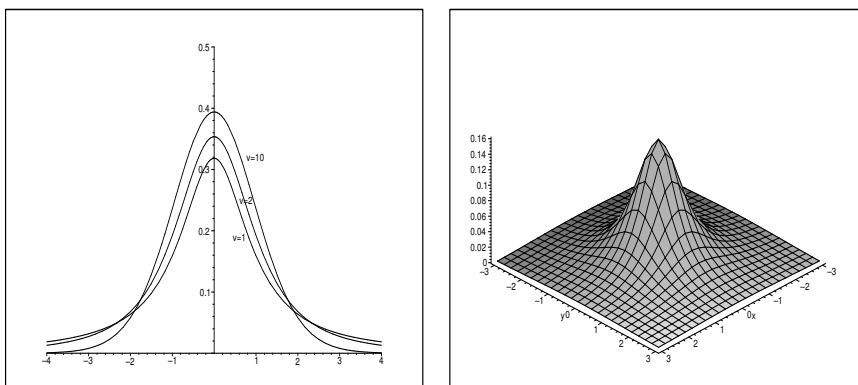

Figure 4.2: Marginal and bivariate student-t density functions

Where we used the substitution  $y = \sqrt{x}$ . Further calculating gives

$$\begin{aligned} c_n &= \frac{\Gamma(n/2)}{(2\pi)^{n/2}} \left[ \int_0^\infty 2y^{n-1} e^{-y\sqrt{2}} dy \right]^{-1} = \frac{\Gamma(n/2)}{(2\pi)^{n/2}} \left[ \frac{2\Gamma(n)}{2^{n/2}} \right]^{-1} \\ &= \frac{\Gamma(n/2)}{2\Gamma(n)\pi^{n/2}} \end{aligned}$$

So the multivariate density function is, by using (4.1),

$$f_X(x) = \frac{\Gamma(n/2)}{2\Gamma(n)\pi^{n/2}} |\Omega|^{-1/2} \exp \left[ -((x - \mu)^T \Omega^{-1} (x - \mu))^{1/2} \right]$$

which is the density function of the multivariate Laplace distribution. Taking  $n = 1$  gives the marginal density, which results in

$$f_{X_k}(x) = \frac{\Gamma(1/2)}{2\Gamma(1)\pi^{1/2}\omega_k} \exp \left[ -\sqrt{\left(\frac{x - \mu_k}{\omega_k}\right)^2} \right] = \frac{1}{2\omega_k} e^{-|x - \mu_k|/\omega_k}$$

This is the well known density function for the Laplace distribution with parameters  $\mu_k$  and  $\omega_k$ . The mean  $E(X)$  equals  $\mu_k$ , but notice that the parameter  $\omega_k$  does not has to be the standard deviation, but, as stated before, is a linear combination of the standard deviation. In fact, the variance (the squared standard deviation) appears to be  $Var(X_k) \equiv \sigma_k^2 = 2\omega_k^2$

Below is shown the marginal density function (with  $\mu_k = 0$  and  $\omega_k = 1$ ) and the bivariate Laplace density with  $\mu = 0$  and  $\Omega$  the identity  $(2 \times 2)$ -matrix.

#### 4.2.4 Logistic family

The last example of a member of the family of elliptical distributions is the distribution with density generator

$$g(u) = \frac{e^{-\sqrt{2u}}}{(1 + e^{-\sqrt{2u}})^2}$$



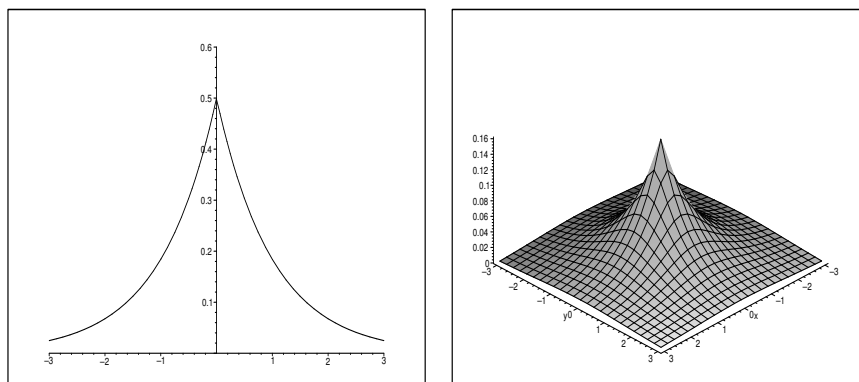

Figure 4.3: Marginal and bivariate Laplace density functions

Note that this is another density generator than proposed by Landsman and Valdez, who don't use the square root sign. By using (4.2) we can calculate  $c_n$ , which gives after many calculations (and noticing that  $\frac{e^{-\sqrt{2x}}}{(1+e^{-\sqrt{2x}})^2} = \sum_{j=1}^{\infty} (-1)^{j-1} j e^{-j\sqrt{2x}}$ ) the following expression

$$c_n = \frac{\Gamma(n/2)}{2\Gamma(n)\pi^{n/2}} \left[ \sum_{j=1}^{\infty} (-1)^{j-1} j^{1-n} \right]^{-1}$$

The multivariate density function can be found by using (4.1), which gives the multivariate logistic density. Taking  $n = 1$  gives the marginal logistic density. Using that  $c_1 = \frac{\Gamma(1/2)}{2\Gamma(1)\pi^{1/2}} \left[ \sum_{j=1}^{\infty} (-1)^{j-1} \right]^{-1} = 1$ , this gives

$$f_{X_k}(x) = \frac{1}{\omega_k} \frac{\exp\left(-\left|\frac{x-\mu_k}{\omega_k}\right|\right)}{\left(1 + \exp\left(-\left|\frac{x-\mu_k}{\omega_k}\right|\right)\right)^2} = \frac{1}{\omega_k} \frac{\exp\left(-\frac{x-\mu_k}{\omega_k}\right)}{\left(1 + \exp\left(-\frac{x-\mu_k}{\omega_k}\right)\right)^2}$$

where we have dropped the absolute value signs because the function is symmetric, which can be seen as follows:

$$\frac{e^{-y}}{(1+e^{-y})^2} = \frac{e^y}{(e^y)^2(1+e^{-y})^2} = \frac{e^y}{(e^y+1)^2}$$

The marginal distribution is, indeed, the logistic density. The mean of this marginal density is  $E(X_k) = \mu_k$ , the standard deviation is again a linear combination of  $\omega_k$ . It is shown that the variance  $Var(X_k) \equiv \sigma_k^2 = \frac{1}{3}\pi^2\omega_k^2$

The next graphs show the marginal density and the bivariate case with  $\mu_k = 0$ ,  $\omega_k = 1$  respectively  $\mu = 0$ ,  $\Omega = I$ , the identity matrix.

#### 4.2.5 Differences and similarities

We have discussed four examples of elliptical distributions. There are many more, like the Bessel, Exponential Power and Stable Laws function. If we compare the four discussed elliptical families we can easily see the differences between them. Especially the tail behavior can be very different, which is exactly

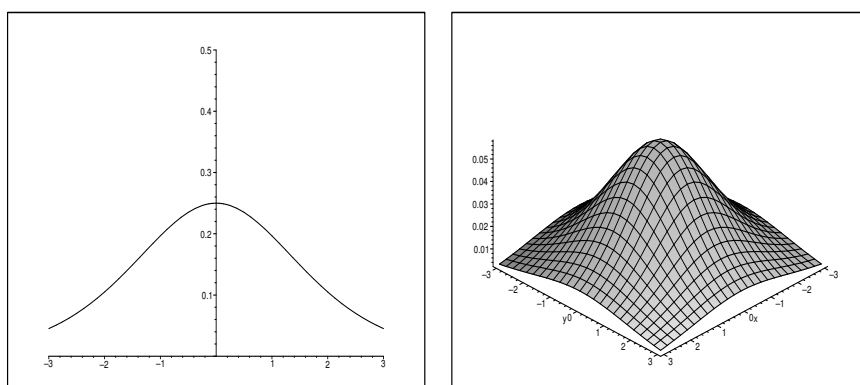

Figure 4.4: Marginal and bivariate Logistic density functions

the reason why we are looking at the family of elliptical distributions instead of only looking at the normal distribution. In the next two figures, we took the parameters in a way that all means equal zero, and all variances equal one. The second figure is an enlargement of the righthand tail, so the differences in the tail become clear.

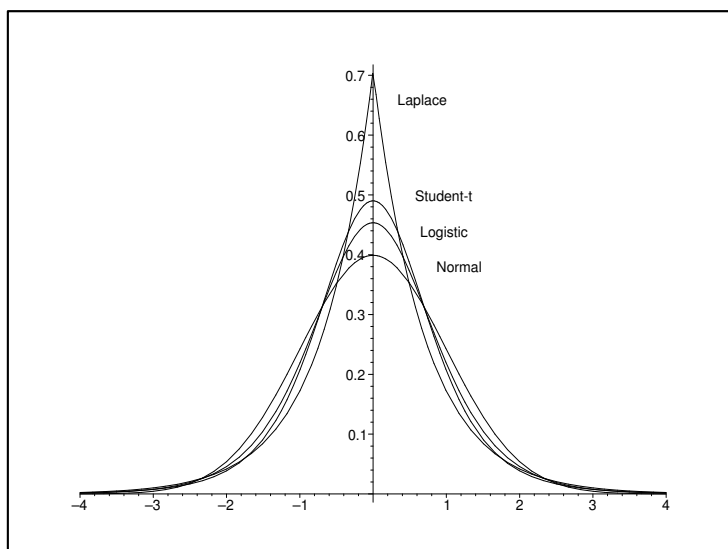

Figure 4.5: Comparison of four elliptical distributions

We have seen that the dispersion matrix  $\Omega$  doesn't have to be the same as the covariance matrix  $\Sigma$ . They are proportional to each other, like mentioned in the four examples in the previous subsections. In general we can say that  $\Sigma = -\psi'(0)\Omega$ , so  $\Omega = (-\psi'(0))^{-1}\Sigma$ , which was earlier mentioned in the introduction of this chapter. For the four examples we gave, we have explicit expressions for the factor  $-\psi'(0)$ , so we can say the following about the dispersion matrix  $\Omega$ ,

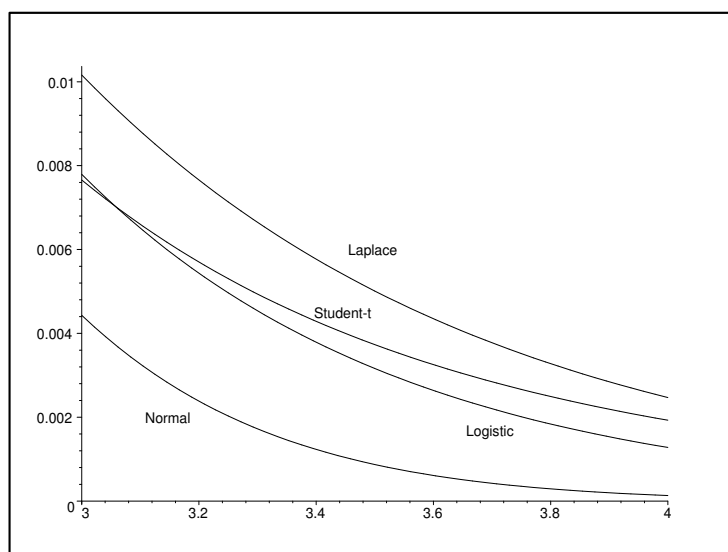

Figure 4.6: Enlargement of the righthand tail

in terms of the covariance matrix:

$$\Omega = \begin{cases} \Sigma & \text{normal} \\ \frac{\nu}{\nu-2}\Sigma & \text{student-t}(\nu) \\ \frac{1}{2}\Sigma & \text{Laplace} \\ \frac{3}{\pi^2}\Sigma & \text{logistic} \end{cases}$$

So the following holds for dispersion, in terms of standard deviation of the  $k$ 'th element:

$$\omega_k = \begin{cases} \sigma_k & \text{normal} \\ \sqrt{\frac{\nu}{\nu-2}}\sigma_k & \text{student-t}(\nu) \\ \frac{1}{\sqrt{2}}\sigma_k & \text{Laplace} \\ \frac{\sqrt{3}}{\pi}\sigma_k & \text{logistic} \end{cases} \quad (4.6)$$

Because we are working in a  $(\mu, \sigma)$ -space, these relationships will be needed to transform expressions in the correct parameters. We already used them in the previous figure, to create probability density functions with the same mean and standard deviation.

### 4.3 Mean-variance analysis

In this section I will show that mean-variance analysis is a valid tool for elliptical distributions. The basic thought with mean-variance analysis is that an investor wants to minimize his variance given some return. If he can choose between portfolios with the same expected return, he will take the portfolio with minimum variance (dispersion). I will show that for every elliptical distribution, the distribution is completely specified by its mean and variance. The higher moments are zero or proportional to the first (mean) or second (variance) moment.

Suppose that an investor has a portfolio  $\theta$  of risky assets with portfolio return  $R_p = r^T \theta = \theta^T r$ , and that the the vector of asset returns has an elliptical distribution:  $r \sim E_n(\mu, \Omega, \psi)$ , with  $\psi$  the characteristic generator as in (4.3),  $\mu$  the mean and dispersion matrix  $\Omega$  (I don't use  $\Sigma$  again on purpose because the dispersion matrix doesn't have to be the covariance matrix). Then the portfolio return is also elliptical distributed, namely  $R_p \sim E_1(\theta^T \mu, \theta^T \Omega \theta, \psi)$ . Define  $\mu_p = \theta^T \mu$  the expected portfolio return and  $\omega^2 = \theta^T \Omega \theta$  the dispersion of the portfolio. The characteristic function of  $R_p$  is, by using (4.3),

$$\phi_p(t) = e^{it\mu_p} \psi\left(\frac{1}{2}t\omega^2 t\right) = e^{it\mu_p} \psi\left(\frac{1}{2}\omega^2 t^2\right)$$

The  $k^{\text{th}}$  central moment about  $R_p$  is defined as

$$E(R_p - \mu_p)^k = \int (X - \mu_p)^k f_p(X) dX \equiv M_k$$

with  $f_p(X)$  the elliptical probability density function of  $R_p$ . As we know, the second central moment  $E(R_p - \mu_p)^2$  is the variance. With this definition we see the following:

$$\begin{aligned} \psi\left(\frac{1}{2}\omega^2 t^2\right) &= \phi_p(t) e^{-it\mu_p} \equiv E e^{itR_p} e^{-it\mu_p} = E e^{it(R_p - \mu_p)} \\ &= \int e^{it(X - \mu_p)} f_p(X) dX = \int \sum_{k=0}^{\infty} \frac{(it(X - \mu_p))^k}{k!} f_p(X) dX \\ &= \sum_{k=0}^{\infty} \frac{(it)^k}{k!} \int (X - \mu_p)^k f_p(X) dX = \sum_{k=0}^{\infty} \frac{(it)^k}{k!} M_k \\ &= 1 + \frac{it}{1!} M_1 + \frac{i^2 t^2}{2!} M_2 + \frac{i^3 t^3}{3!} M_3 + \dots \end{aligned}$$

By noticing that the  $m^{\text{th}}$  derivative of  $\frac{i^k t^k}{k!} M_k$  is

$$\frac{d^m}{dt^m} \left( \frac{i^k t^k}{k!} M_k \right) = \begin{cases} 0 & \text{for } k < m \\ \frac{m(m-1)(m-2)\dots(2)(1)i^m t^0}{m!} M_m = i^m M_m & \text{for } k = m \\ \frac{k(k-1)(k-2)\dots(k-m+1)i^k t^{k-m}}{k!} M_k = \frac{i^k t^{k-m}}{(k-m)!} M_k & \text{for } k > m \end{cases}$$

we see that

$$\left. \frac{d^m}{dt^m} \left( \psi\left(\frac{1}{2}\omega^2 t^2\right) \right) \right|_{t=0} = \left. \frac{d^m}{dt^m} \left( \sum_{k=0}^{\infty} \frac{(it)^k}{k!} M_k \right) \right|_{t=0} = i^m M_m$$

So the the  $m^{\text{th}}$  central moment of  $R_p$  will be

$$M_m = i^{-m} \left. \frac{d^m}{dt^m} \psi\left(\frac{1}{2}\omega^2 t^2\right) \right|_{t=0}$$

The following holds for the  $m^{\text{th}}$  derivative of  $\psi\left(\frac{1}{2}\omega^2 t^2\right)$ , with **even**  $m$ :

$$\begin{cases} \frac{d^m}{dt^m} \psi\left(\frac{1}{2}\omega^2 t^2\right) &= \sum_{l=0}^{m/2} C_{ml} \psi^{(m-l)}\left(\frac{1}{2}\omega^2 t^2\right) \omega^{2(m-l)} t^{m-2l} \\ \frac{d^{m+1}}{dt^{m+1}} \psi\left(\frac{1}{2}\omega^2 t^2\right) &= \sum_{l=0}^{m/2} C_{m+1,l} \psi^{(m+1-l)}\left(\frac{1}{2}\omega^2 t^2\right) \omega^{2(m+1-l)} t^{m+1-2l} \end{cases}$$

where  $C_{ml}$  are constants for all  $m, l$ . This is easy to prove using induction. Using this result we see that the  $m^{\text{th}}$  moment can be written as

$$\begin{cases} M_m &= C_m \psi^{(m/2)}(0) \omega^{2(m/2)} = C'_m \omega^m \\ M_{m+1} &= 0 \end{cases} \quad \text{for } m \text{ even}$$

with  $C_m, C'_m$  constants. We used that, for even  $m$ , both  $i^{-m}$  and  $\psi^{(m/2)}(0)$  are real constants, and these are included in the constant  $C'_m$ .

We see that all odd central moments are zero (this result is not a big surprise because every marginal elliptical distribution is, according to (4.5), symmetric around  $\mu$ ), and all even central moments are proportional to  $\omega^m$ . Therefore, if the density generator is chosen, the distribution of the portfolio return is completely characterized by the first two moments, or by mean  $\mu_p$  and dispersion  $\omega$ . The first two central moments are

$$M_1 = 0 \quad (\text{so } E(R_p) = \mu_p)$$

$$M_2 = \text{Var}(R_p) = -\psi'(0)\omega^2$$

Note that if  $\psi'(0) = -1$ , the dispersion  $\omega$  is equivalent to the standard deviation  $\sigma_p$ . We have seen this before in the introduction of this chapter.

The result of this proof is that the Telser analysis we did with the normal distribution, can be easily extended to all elliptical distributions, which we will do in the next section.

## 4.4 Telser and elliptically distributed returns

In the previous chapter we have developed a solution for the optimal investment policy with Telser's approach, where we assumed that asset returns are normally distributed. In this section we will do the same for elliptically distributed returns.

Suppose that asset returns have a multivariate elliptical distribution. So

$$r \sim E_n(\mu, \Omega, g_n)$$

with expected return vector  $\mu$ , dispersion matrix  $\Omega$  and density generator  $g_n(\cdot)$ . We know that the covariance matrix  $\Sigma$  is proportional to  $\Omega$  and is determined by  $-\psi'(0)\Omega$ . It follows from the theory (4.4) that the portfolio return is distributed by

$$R_p = r^T \theta = \theta^T r \sim E_1(\theta^T \mu, \theta^T \Omega \theta, g_1)$$

If we apply  $\mu_p = \theta^T \mu$  and  $\omega_p^2 = \theta^T \Omega \theta$  this gives

$$R_p \sim E_1(\mu_p, \omega_p^2, g_1)$$

Note that the portfolios variance is determined by  $\sigma_p^2 = -\psi'(0)\omega_p^2$ . Then by (4.1) the probability density function of  $R_p$  has the following form

$$f_p(x) = \frac{c_1}{\omega_p} g_1 \left[ \frac{1}{2} \left( \frac{x - \mu_p}{\omega_p} \right)^2 \right]$$

with constant  $c_1$  defined (by (4.2)) as

$$c_1 = \frac{\Gamma(1/2)}{(2\pi)^{1/2}} \left[ \int_0^\infty x^{1/2-1} g_1(x) dx \right]^{-1} = \frac{1}{\sqrt{2}} \left[ \int_0^\infty \frac{1}{\sqrt{x}} g_1(x) dx \right]^{-1}$$

Telser's portfolio optimization approach is to maximize the expected return subject to the budget constraint that there is a fixed probability of getting into default. Remember that the budget constraint is

$$P(R_p \leq -C_0) \leq \alpha$$

Since  $R_p$  is elliptically distributed, we can write the probability as

$$P(R_p \leq -C_0) = \int_{x=-\infty}^{-C_0} \frac{c_1}{\omega_p} g_1 \left[ \frac{1}{2} \left( \frac{x - \mu_p}{\omega_p} \right)^2 \right] dx$$

Use the substitution

$$z = \frac{x - \mu_p}{\omega_p} \Rightarrow x = z\omega_p + \mu_p \Rightarrow dx = \omega_p dz$$

which gives

$$P(R_p \leq -C_0) = \int_{z=-\infty}^{\frac{-C_0 - \mu_p}{\omega_p}} \frac{c_1}{\omega_p} g_1 \left[ \frac{1}{2} z^2 \right] \omega_p dz = \int_{z=-\infty}^{\frac{-C_0 - \mu_p}{\omega_p}} c_1 g_1 \left[ \frac{1}{2} z^2 \right] dz$$

Finally define  $k_\alpha$  as the quantile for which

$$\int_{z=-\infty}^{k_\alpha} c_1 g_1 \left[ \frac{1}{2} z^2 \right] dz = \alpha \quad (4.7)$$

Note that  $k_\alpha$  only depends on the density generator  $g(u)$  and the probability  $\alpha$ . For example, take the normal distribution. We have seen that  $g(u) = e^{-u}$ ,  $c_1 = \frac{1}{\sqrt{2\pi}}$ . So for the normal distribution the  $k_\alpha$  for a probability of  $\alpha = 0.01$  is the solution of

$$\int_{z=-\infty}^{k_\alpha} \frac{1}{\sqrt{2\pi}} e^{-\frac{1}{2}z^2} dz = 0.01$$

The solution is  $k_{0.01} = -2.33$  which is the same as the value for the normalized quantile  $k_\alpha$  for the normal distribution defined in the previous chapter. So from now on,  $k_\alpha$  represents the dispersion standardized  $\alpha$ -quantile of an elliptical distribution. In the table below, some quantiles  $k_\alpha$  for the previously discussed elliptical distributions are shown.

Now we can write for the budget constraint

$$P(R_p \leq -C_0) \leq \alpha \Rightarrow \frac{-C_0 - \mu_p}{\omega_p} \leq k_\alpha \Rightarrow \mu_p \geq -C_0 - k_\alpha \omega_p$$

with  $k_\alpha$  defined as in (4.7). Because we are working in a  $(\mu, \sigma)$ -space, it is preferable to express the dispersion  $\omega_p$  in terms of standard deviation  $\sigma_p$ . Using (4.6) for our discussed elliptical distributions, this gives

$$\mu_p \geq -C_0 - k_\alpha \omega_p = \begin{cases} -C_0 - k_\alpha \sigma_p & \text{normal} \\ -C_0 - k_\alpha \sqrt{\frac{\nu-2}{\nu}} \sigma_p & \text{student-t}(\nu) \\ -C_0 - k_\alpha \frac{1}{\sqrt{2}} \sigma_p & \text{Laplace} \\ -C_0 - k_\alpha \frac{\sqrt{3}}{\pi} \sigma_p & \text{logistic} \end{cases}$$

	Normal	Student-t ( $\nu = 1$ )	Student-t ( $\nu = 10$ )	Laplace	Logistic
$\alpha = 0.5$	0	0	0	0	0
$\alpha = 0.1$	-1.28	-3.08	-1.37	-1.61	-2.20
$\alpha = 0.01$	-2.33	-31.82	-2.76	-3.91	-4.60
$\alpha = 0.001$	-3.09	-318.3	-4.14	-6.21	-6.91
$\alpha = 0.0001$	-3.72	-3183	-5.69	-8.52	-9.21

Table 4.1: The quantiles  $k_\alpha$  for some elliptical distributions

From now on we will write

$$\mu_p \geq -C_0 - z_\alpha \sigma_p \quad \text{with} \quad z_\alpha \equiv \frac{k_\alpha \omega_p}{\sigma_p} \quad (4.8)$$

for all elliptical distributions. So for example if returns are distributed according to a Laplace distribution, then  $z_\alpha = k_\alpha \frac{1}{\sqrt{2}}$ . The quantile  $z_\alpha$  can be interpreted as the standard deviation standardized elliptical quantile, we will refer to  $z_\alpha$  as the standardized quantile.

Using this definition, the Telser-optimization problem can be written as

$$Max \left\{ \mu_p \left\{ \begin{array}{l} \mu_p \geq -C_0 - z_\alpha \sigma_p \\ \bar{1}^T \theta = C_0 \\ \mu_p = \mu^T \theta \\ \sigma_p^2 = \theta^T \Sigma \theta \end{array} \right. \right\} \quad (4.9)$$

This system is solved in exact the same way as we did for normally distributed returns, except with the quantile  $z_\alpha$  instead of  $k_\alpha$ . So the optimal solution can be given immediately by looking at the results of the previous chapter. We have for the case without risk-free asset

$$\theta_T = \frac{1}{d} \Sigma^{-1} ((a\bar{1} - b\mu)C_0 + (c\mu - b\bar{1})\mu_T)$$

with

$$\mu_T = \frac{bz_\alpha^2 + d + \sqrt{dz_\alpha^2(a + 2b + c - z_\alpha^2)}}{cz_\alpha^2 - d} C_0$$

If the risk-free asset is added, with rate of return  $\mu_f$ , the optimal portfolio allocation changes in

$$\theta_T \equiv \begin{pmatrix} \theta_1 \\ \vdots \\ \theta_N \\ \theta_f \end{pmatrix} = \begin{pmatrix} \frac{1+\mu_f}{s(z_\alpha)} \Sigma^{-1} (\mu_f \bar{1} - \mu) C_0 \\ \frac{a+b-(b+c)\mu_f+z_\alpha s}{s(z_\alpha)} C_0 \end{pmatrix}$$

## 4.5 Example

In the previous chapter we continued our example of finding the optimal asset allocation with seven securities from the Dutch AEX-index. We assumed that the yearly returns were distributed normal, but mentioned that it is very difficult

to find out the real yearly distribution of returns. Main reason was that the yearly time interval is too long to have enough relevant data.

Here we will show what the optimal Telser portfolios are if the yearly returns are elliptical. We assume the normal, student-t for different degrees of freedom, Laplace and logistic distribution to see what happens with the optimum. The shortfall probability remains  $\alpha = 0.0001$ . The quantiles  $k_\alpha$  are shown in the next table.

	$k_\alpha$		no risk-free asset		with risk-free asset	
	$k_\alpha$	$z_\alpha$	$\mu_T$	$\sigma_T$	$\mu_T$	$\sigma_T$
Normal	-3.719	-3.719	0.158	0.311	0.158	0.311
Student-t(3)	-22.204	-12.819	†	†	0.071	0.084
Student-t(5)	-9.678	-7.496	†	†	0.095	0.146
Student-t(7)	-7.063	-5.970	0.097	0.184	0.110	0.186
Student-t(9)	-6.010	-5.300	0.116	0.211	0.120	0.211
Laplace	-8.517	-6.023	0.095	0.182	0.110	0.184
Logistic	-9.210	-5.078	0.121	0.221	0.124	0.221

Table 4.2: The quantiles  $k_\alpha$  for some elliptical distributions

The †-sign means that there is no solution of the problem. This is because for the quantile  $z_\alpha$  we must have that

$$|z_\alpha| < \sqrt{a + 2b + c} = 6.145$$

to guarantee an optimal solution, which is explained in appendix B. This is clearly not the case when yearly returns are assumed student-t distributed with 3 or 5 degrees of freedom. Graphically this can be interpreted that the slope of the shortfall line is too steep, and doesn't have a point of intersection with the efficient frontier, so there is not any point that satisfies the shortfall constraint. In other words, there is no possible asset allocation that will not lose more than the invested capital  $C_0$  with a probability smaller than  $\alpha$ .

Looking at the table we see that all policies are more conservative than when the normal distribution is used. This is because the used distributions all have greater quantiles (at the shortfall probability  $\alpha$ ) than the normal distribution, or in other words, they have fatter tails: a very bad result is expected to happen more often. To satisfy the shortfall constraint the investor must decrease his expected return, so all means are lower than with normally distributed returns. The optimal allocations  $\theta$  belonging to the table above are

Normal	t(3)	t(5)	Stud-t(7)	Stud-t(9)	Laplace	logistic
-0.088			0.087	0.033	0.093	0.017
-0.150			-0.033	-0.069	-0.029	-0.079
-0.069			-0.003	-0.023	-0.001	-0.029
1.285	†	†	0.492	0.736	0.463	0.806
0.219			0.036	0.092	0.029	0.108
-0.164			0.219	0.101	0.233	0.068
-0.033			0.203	0.130	0.211	0.109

Table 4.3: Optimal Telser allocation  $\theta$  for different yearly distributions



We see that the importance of Heineken and Philips is adjusted downwards when more fat-tailed distributions are used. The securities Royal Dutch and Unilever become more important. In a Markowitz context we can say that the optimum is moving to in the direction of the minimum variance portfolio. If the risk-free asset is added, we have the following optimal Telser allocations:

Normal	t(3)	t(5)	t(7)	t(9)	Laplace	logistic
-0.058	-0.016	-0.027	-0.035	-0.040	-0.034	-0.041
-0.141	-0.038	-0.066	-0.084	-0.096	-0.084	-0.100
-0.062	-0.017	-0.029	-0.037	-0.042	-0.037	-0.044
1.258	0.338	0.590	0.751	0.854	0.744	0.894
0.203	0.055	0.095	0.121	0.138	0.120	0.144
-0.094	-0.025	-0.044	-0.056	-0.064	-0.056	-0.067
0.018	0.005	0.009	0.011	0.012	0.011	0.013
-0.124	0.699	0.473	0.329	0.238	0.335	0.202

Table 4.4: The optimal Telser allocation  $\theta$ , with risk-free asset, for different yearly distributions.

We see that the greater the quantile  $z_\alpha$ , the more an investor invests at the risk-free rate. So when the shortfall line is becoming steeper, the investor chooses for more safety and invests more in the risk-free asset.

In a figure, the Telser portfolios with elliptically distributed returns look like the following. The right figure is a zoomed version of the left figure. The used shortfall lines are with the normal distribution and the student-t with 3,5,7 and 9 degrees of freedom. We also see the efficient frontier(EF), the capital market line (CML) and the market portfolio (m). Note that there is no optimal solution if we deal without risk-free asset and assume a student-t(3) or a student-t(5) distribution, which corresponds with the † in the tables before.

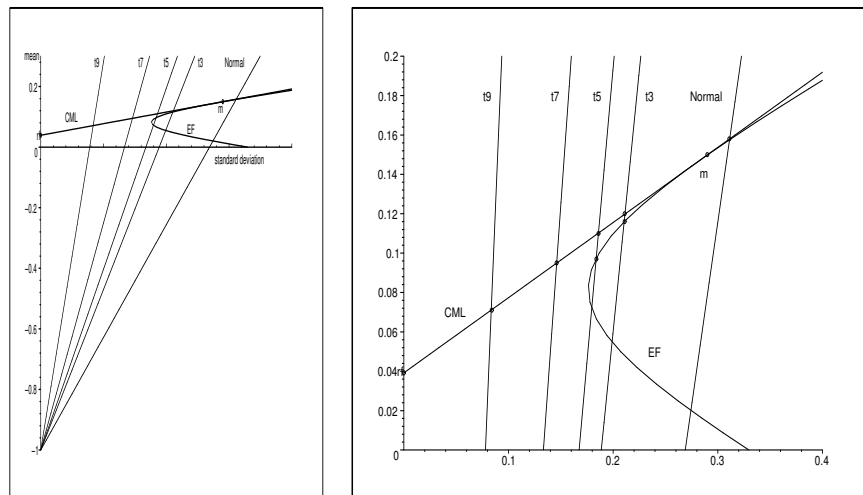

Figure 4.7: The Telser portfolios with different elliptical distributions

## 4.6 References

- Billio, Casarin, Toniolo [2002] *Extreme Returns in a Shortfall Risk Framework*
- Embrechts, McNeil, Straumann [1999] *Correlation and Dependence in Risk Management: Properties and Pitfalls*
- Frahm, Junker, Szimayer [2002] *Elliptical Copulas: Applicability and Limitations*
- Hodoshima [2001] *The Effects on Nonnormality on the Market Model in the Class of Elliptical Distributions*
- Hult, Lindskog [2001] *Multivariate Extremes, Aggregation and Dependence in Elliptical Distributions*
- Ingersoll [1987] *Theory of Financial Decision Making*
- Landsman, Valdez [2002] *Tail Conditional Expectations for Elliptical Distributions*
- Lindskog [2000] *Linear Correlation Estimation*
- Owen, Rabinovitch [1983] "On the class of Elliptical Distributions and their applications to the Theory of Portfolio Choice" *The Journal of Finance* Vol.38, No.3
- Rice [1995] *Mathematical Statistics and Data Analysis*
- Telser [1955] "Safety-first and Hedging" *Review of Economic Studies* 23
- Valdez, Chernih [2003] *Wang's Capital Allocation Formula for Elliptically-Contoured Distributions*



---

## Value at Risk based optimization

---

We have seen that the Telser optimization method is not based on standard deviation as the risk measure. The measure of risk is the probability of getting in default,  $P(R_p \leq -C_0)$ . This risk measure is a special case of the world wide used *Value at Risk* risk measure (VaR). We will discuss the Value at Risk, and portfolio optimization with a VaR constraint, in this chapter.

First the mean-VaR efficient frontier will be derived, both with and without risk-free asset. Section 3 calculates the optimal portfolios with a VaR-constraint, like we did with the Markowitz and Telser framework. The last two sections are for the example and references.

### 5.1 VaR efficient frontier

The VaR at level  $1 - \alpha$  of a portfolio ( $VaR_\alpha$ ) is defined by

$$P(R_p \leq -VaR_\alpha) = \alpha$$

In words we can say that it is the minimum amount an investor can loose (in dollars) with a confidence interval of  $1 - \alpha$ . The bigger the VaR at some confidence level, the more risky the portfolio is. So an investor who is extreme risk averse will prefer an extreme low VaR. The figure below shows the graphical interpretation of the VaR risk measure.

If we take  $VaR_\alpha = C_0$  and  $\alpha$  the shortfall probability, then the VaR definition becomes the shortfall constraint of the previous chapter. So a shortfall constraint is a special case of a VaR constraint.

Because Value at Risk is our new risk measure, instead of standard deviation, a new efficient frontier can be calculated, just as we did in the mean-standard deviation framework. The Efficient frontier gives the highest expected return

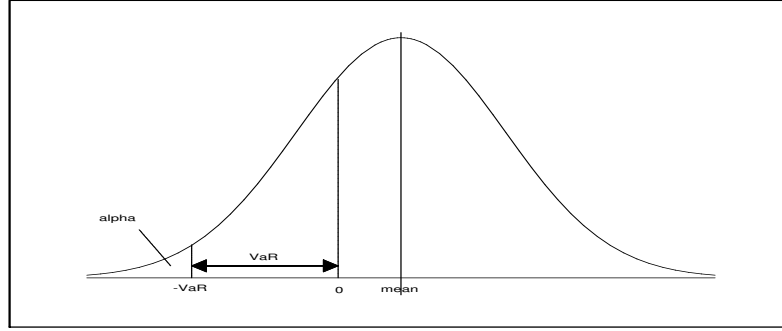

Figure 5.1: Definition of Value at Risk

for some given Value at Risk, or the minimum VaR for a fixed mean. It appears that the efficient mean-VaR frontier is the same as the efficient mean-standard deviation frontier, when returns are elliptically distributed, which we will show. For the calculations in this chapter we will assume returns are elliptically distributed.

When the elliptical assumption is made, the Value at Risk can be written as

$$\begin{aligned} P(R_p \leq -VaR_\alpha) = \alpha &\iff P\left(\frac{R_p - \mu_p}{\omega_p} \leq \frac{-VaR_\alpha - \mu_p}{\omega_p}\right) = \alpha \\ &\iff \frac{-VaR_\alpha - \mu_p}{\omega_p} = k_\alpha \iff VaR_\alpha = -\mu_p - k_\alpha \omega_p \end{aligned}$$

If we use substitution (4.8), the VaR can be written in terms of mean and standard deviation:

$$VaR_\alpha = -\mu_p - z_\alpha \sigma_p \quad (5.1)$$

Remember the negative value of  $z_\alpha$ . The efficient frontier consists of the points where, for a given mean, the VaR is minimized. It is also defined by the points where, for a given VaR, the mean return is maximized. We will work with the latter definition, which is in formulas:

$$Max \left\{ \mu_p \left| \begin{array}{l} VaR_\alpha = -\mu_p - z_\alpha \sigma_p \\ \mu_p = \mu^T \theta \\ \sigma_p^2 = \theta^T \Sigma \theta \\ \mathbf{1}^T \theta = C_0 \end{array} \right. \right\} \quad (5.2)$$

The first constraint of (5.2) can be transformed to

$$(VaR_\alpha + \mu_p)^2 = (-z_\alpha \sigma_p)^2 \iff VaR_\alpha^2 + 2VaR_\alpha \mu_p + \mu_p^2 - z_\alpha^2 \sigma_p^2 = 0$$

and if we substitute the other constraints we get

$$\begin{aligned} VaR_\alpha^2 + 2VaR_\alpha \mu^T \theta + \theta^T \mu \mu^T \theta - z_\alpha^2 \theta^T \Sigma \theta &= 0 \\ \iff VaR_\alpha^2 + 2VaR_\alpha \mu^T \theta + \theta^T \Psi \theta &= 0 \end{aligned}$$

where the matrix  $\Psi$  is defined as

$$\Psi = \mu \mu^T - z_\alpha^2 \Sigma$$

The maximization problem (5.2) then becomes shorter:

$$\text{Max} \left\{ \mu^T \theta \mid \begin{array}{l} VaR_\alpha^2 + 2VaR_\alpha \mu^T \theta + \theta^T \Psi \theta = 0 \\ \bar{1}^T \theta = C_0 \end{array} \right\} \quad (5.3)$$

$\Psi$  is symmetric, because

$$\Psi^T = (\mu \mu^T - z_\alpha^2 \Sigma)^T = (\mu \mu^T)^T - z_\alpha^2 \Sigma^T = \mu \mu^T - z_\alpha^2 \Sigma = \Psi$$

As before, we define the following constants:

$$\begin{aligned} \hat{a} &\equiv \mu^T \Psi^{-1} \mu \\ \hat{b} &\equiv \mu^T \Psi^{-1} \bar{1} = \bar{1}^T \Psi^{-1} \mu \\ \hat{c} &\equiv \bar{1}^T \Psi^{-1} \bar{1} \\ \hat{d} &\equiv \hat{a} \hat{c} - \hat{b}^2 \end{aligned}$$

The relationship between the constants  $\hat{a}, \hat{b}, \hat{c}, \hat{d}$  and the familiar constants from the previous chapters  $a, b, c, d$  can be easily derived. The following holds for the inverse covariance matrix

$$\Sigma^{-1} = \Sigma^{-1} \Psi \Psi^{-1} = \Sigma^{-1} (\mu \mu^T - z_\alpha^2 \Sigma) \Psi^{-1} = \Sigma^{-1} \mu \mu^T \Psi^{-1} - z_\alpha^2 \Psi^{-1}$$

Using this expression for  $\Sigma^{-1}$  we have

$$\begin{cases} a = \mu^T \Sigma^{-1} \mu = \mu^T \Sigma^{-1} \mu \mu^T \Psi^{-1} \mu - z_\alpha^2 \mu^T \Psi^{-1} \mu = a \hat{a} - z_\alpha^2 \hat{a} & = \hat{a}(a - z_\alpha^2) \\ b = \mu^T \Sigma^{-1} \bar{1} = \mu^T \Sigma^{-1} \mu \mu^T \Psi^{-1} \bar{1} - z_\alpha^2 \mu^T \Psi^{-1} \bar{1} = a \hat{b} - z_\alpha^2 \hat{b} & = \hat{b}(a - z_\alpha^2) \\ c = \bar{1}^T \Sigma^{-1} \bar{1} = \bar{1}^T \Sigma^{-1} \mu \mu^T \Psi^{-1} \bar{1} - z_\alpha^2 \bar{1}^T \Psi^{-1} \bar{1} & = \hat{b} \hat{b} - z_\alpha^2 \hat{c} \end{cases}$$

We solve this set to get the desired expressions, and get

$$\begin{cases} \hat{a} &= \frac{a}{a - z_\alpha^2} \\ \hat{b} &= \frac{b}{a - z_\alpha^2} \\ \hat{c} &= \frac{c z_\alpha^2 - d}{z_\alpha^2 (a - z_\alpha^2)} \\ \hat{d} &= \hat{a} \hat{c} - \hat{b}^2 = \frac{-d}{z_\alpha^2 (a - z_\alpha^2)} \end{cases} \quad (5.4)$$

Later on we will use this results to compare the derived results with previous findings.

We solve the problem (5.3) using the Lagrange method. This gives the following set of equations

$$\begin{cases} \mu + 2\lambda_1 VaR_\alpha \mu + 2\lambda_1 \Psi \theta + \lambda_2 \bar{1} = 0 & (a) \\ VaR_\alpha^2 + 2VaR_\alpha \mu^T \theta + \theta^T \Psi \theta = 0 & (b) \\ \bar{1}^T \theta = C_0 & (c) \end{cases}$$

Solving equation (a) for  $\theta$  gives, with  $\lambda_3 = \frac{1}{-2\lambda_1}$  and  $\lambda_4 = -\frac{\lambda_2}{2\lambda_1}$ :

$$\theta = (\lambda_3 - VaR_\alpha) \Psi^{-1} \mu + \lambda_4 \Psi^{-1} \bar{1} \quad (5.5)$$

Using this  $\theta$  in (c), we get an expression for  $\lambda_4$ :

$$\bar{1}^T \theta = (\lambda_3 - VaR_\alpha) \hat{b} + \lambda_4 \hat{c} = C_0$$

$$\iff \lambda_4 = \frac{C_0 + \hat{b}VaR_\alpha - \lambda_3\hat{b}}{\hat{c}}$$

The calculation of  $\lambda_3$  follows from (b). After many calculations, which are shown in appendix A, we get

$$\lambda_3^2 = \frac{1}{\hat{d}} \left( VaR_\alpha^2 (\hat{d} - \hat{c}) - 2C_0\hat{b}VaR_\alpha - C_0^2 \right)$$

So

$$\lambda_3 = \pm \sqrt{\frac{1}{\hat{d}} \left( VaR_\alpha^2 (\hat{d} - \hat{c}) - 2C_0\hat{b}VaR_\alpha - C_0^2 \right)} \equiv \pm \sqrt{W}$$

Since we now have values for  $\lambda_3$  and  $\lambda_4$ , we calculate  $\theta$  using (5.5), which gives

$$\theta = (\pm\sqrt{W} - VaR_\alpha)\Psi^{-1}\mu + \frac{1}{\hat{c}}(C_0 + VaR_\alpha\hat{b} \mp \sqrt{W})\Psi^{-1}\bar{1}$$

So the desired expression for the portfolio mean, as a function of the Value at Risk, is

$$\begin{aligned} \mu_p = \mu^T\theta &= (\pm\sqrt{W} - VaR_\alpha)\hat{a} + \frac{1}{\hat{c}}(C_0 + VaR_\alpha\hat{b} \mp \sqrt{W})\hat{b} \\ &= \frac{\hat{d}}{\hat{c}} \left( \pm\sqrt{W} - VaR_\alpha + \frac{\hat{b}}{\hat{d}}C_0 \right) \end{aligned} \quad (5.6)$$

Using the minus sign in this expression gives the mean-VaR efficient frontier. To compare this frontier with the mean-standard deviation efficient frontier, we first invert the function (write  $VaR_\alpha$  as a function of  $\mu_p$ ). In (5.6), we isolate  $\sqrt{W}$ , take squares on both sides and solve the arisen quadratic function for  $VaR_\alpha$ . This gives:

$$VaR_\alpha = -\mu_p + \sqrt{\frac{1}{\hat{d}} \left( (\hat{d} - \hat{c})\mu_p^2 + 2\hat{b}C_0\mu_p - \hat{a}C_0^2 \right)}$$

The second step is to substitute the constants  $\hat{a}, \hat{b}, \hat{c}, \hat{d}$  for constants  $a, b, c, d$ . We use substitution (5.4) for this, and get

$$VaR_\alpha = -\mu_p - z_\alpha \sqrt{\frac{1}{d} (c\mu_p^2 - 2bC_0\mu_p + aC_0^2)} \quad (5.7)$$

The last step is to transform this equation to the mean-standard deviation framework. We use the substitution (5.1) for  $VaR_\alpha$  and get

$$-\mu_p - z_\alpha\sigma_p = -\mu_p - z_\alpha \sqrt{\frac{1}{d} (c\mu_p^2 - 2bC_0\mu_p + aC_0^2)}$$

where  $z_\alpha$  is assumed to be negative. So the mean-VaR efficient frontier in a mean-standard deviation framework is given by

$$\sigma_p = \sqrt{\frac{1}{d} (c\mu_p^2 - 2bC_0\mu_p + aC_0^2)} \quad (5.8)$$

which we recognize as the mean-variance efficient frontier! So our conclusion can be that minimizing the variance is the same as minimizing the Value at Risk, when returns are elliptically distributed.

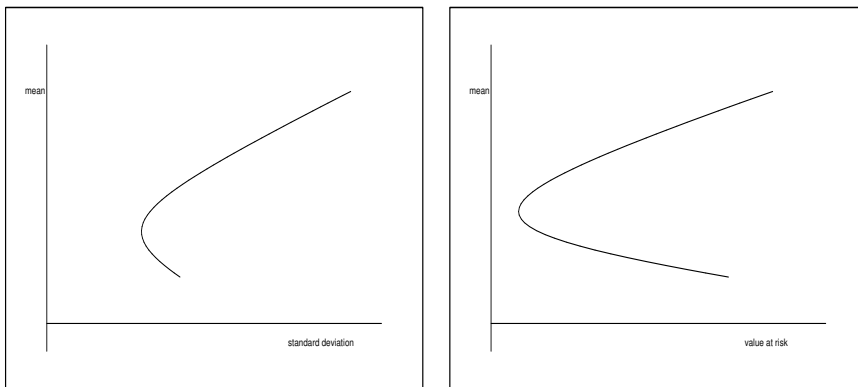

Figure 5.2: The efficient frontier in mean-standard deviation and mean-VaR framework

The two frontiers are shown in the following two graphs, the left figure is the efficient frontier in a mean-standard deviation framework, the right figure is the same efficient frontier in a mean-VaR framework.

Because the mean-standard deviation efficient frontier and the mean-VaR efficient frontier are the same, the allocation at the frontier is still given (in terms of  $\mu_p$ ) by (2.3).

We have seen analytically what the relationship is between the efficient frontiers in mean-standard deviation space and mean-VaR space. This relationship can also be shown in a figure, as shown below. The slope of the shortfall lines in the left graph depends on the (elliptical) distribution of returns and the shortfall probability  $\alpha$ , but is a fixed constant. The values  $p, q, r$  in the left graph are similar to the values  $p, q, r$  in the right graph, so the cross-lines in the right graph have slope 1.

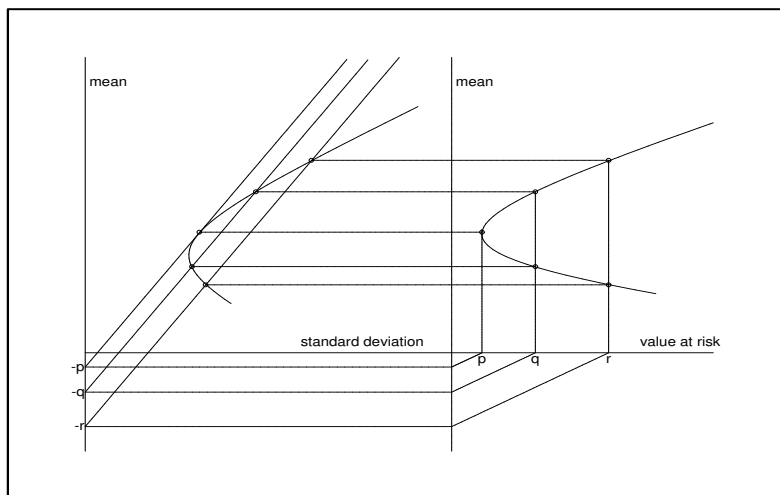

Figure 5.3: Graphical relationship of the efficient frontier in mean-st.dev. and mean-VaR framework.



## 5.2 Adding the risk-free asset

In the mean-standard deviation framework, the efficient frontier changes into the capital market line when a risk-free asset is introduced. An investor then will invest in a combination of the market portfolio and the risk-free asset. Remember that the CML is given by

$$\mu_p = s\sigma_p + C_0\mu_f \quad \text{with} \quad s = \sqrt{c\mu_f^2 - 2b\mu_f + a} \quad (5.9)$$

The constant  $s$  is the slope of the CML. The representation of the CML in the mean-VaR framework can be derived using (5.1) as an expression for  $\sigma_p$  and substituting this in (5.9). This gives

$$\mu_p = s\sigma_p + C_0\mu_f = s \left( \frac{-VaR_\alpha - \mu_p}{z_\alpha} \right) + C_0\mu_f$$

which results in the CML for the mean-VaR framework:

$$\mu_p = \frac{-s}{z_\alpha + s} VaR_\alpha + \frac{z_\alpha\mu_f}{z_\alpha + s} C_0 \quad (5.10)$$

The figure below shows the capital market line in the two settings. The construction lines show how the two lines are related to each other. The point of

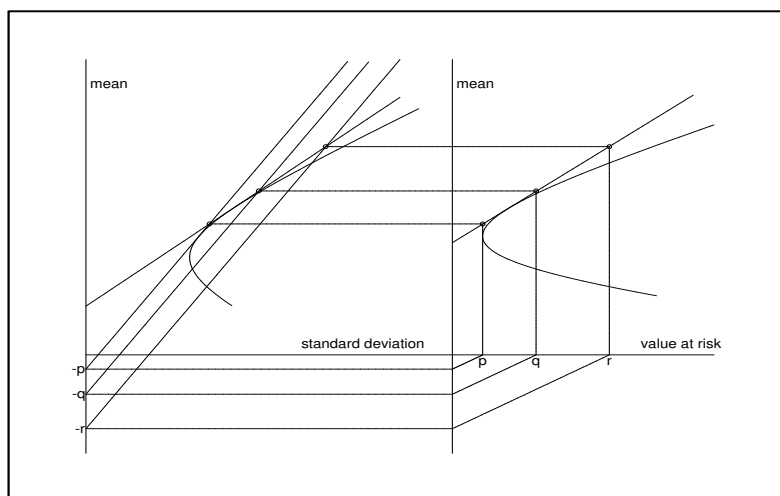

Figure 5.4: Graphical relationship of the CML in mean-st.dev. and mean-VaR framework.

tangency between the CML and the efficient frontier is the market portfolio. We have seen in the Markowitz chapter that the mean return in the market portfolio is  $\mu_m = \frac{a - b\mu_f}{b - c\mu_f} C_0$ . To see which Value at Risk belongs to the market portfolio we equalize  $\mu_m$  with (5.10) and get

$$\frac{a - b\mu_f}{b - c\mu_f} C_0 = \frac{-s}{z_\alpha + s} VaR_\alpha + \frac{z_\alpha\mu_f}{z_\alpha + s} C_0$$

which results in

$$VaR_m = \frac{b\mu_f - a - z_\alpha s}{b - c\mu_f} C_0$$

where we used the substitution  $s^2 = c\mu_f^2 - 2b\mu_f + a$ . So  $(VaR_m, \mu_m)$  is the market portfolio in the mean-VaR framework. The allocation  $\theta_m$  remains the allocation calculated in the mean-standard deviation market portfolio section.

## 5.3 Optimal portfolios

Like we did in the mean-standard deviation framework, we can derive different optimal portfolios in the mean-VaR framework. An investor can choose to invest in the *minimum Value at Risk* portfolio, which is the portfolio that minimizes the VaR. The minimum VaR portfolio differs from the minimum variance portfolio, which can be seen by comparing the efficient frontiers in both frameworks. Another interesting portfolio is the *tangency* portfolio in the mean-VaR framework. This is the portfolio that maximizes the ratio mean/VaR, so it gives the portfolio with maximal return per unity VaR. Looking in a Telser context, we can calculate the *optimal Telser* portfolio, which is the portfolio that maximizes the expected return, while satisfying a Value at Risk constraint. We will look at this in a framework with and without a risk-free asset.

### 5.3.1 Minimum Value at Risk portfolio

The minimum Value at Risk portfolio is the portfolio that minimizes the Value at Risk. Because we have derived formula (5.7) as the efficient frontier, we only have to set the derivative of this function to zero and solve it for  $\mu_p$ . We get

$$\frac{\partial VaR_\alpha}{\partial \mu_p} = -1 - \frac{z_\alpha (c\mu_p - bC_0)}{d\sqrt{\frac{1}{d}(c\mu_p^2 - 2bC_0\mu_p + aC_0^2)}} = 0 \quad (5.11)$$

Solving this for  $\mu_p$  results in the minimum VaR expected return

$$\mu_{mvr} = \left( \frac{b}{c} + \frac{d}{c\sqrt{cz_\alpha^2 - d}} \right) C_0$$

The corresponding Value at Risk is calculated by using (5.7):

$$\begin{aligned} VaR_{mvr} &= -\mu_{mvr} - z_\alpha \sqrt{\frac{1}{d}(c\mu_{mvr}^2 - 2bC_0\mu_{mvr} + aC_0^2)} \\ &= \left( -\frac{b}{c} + \frac{1}{c}\sqrt{cz_\alpha^2 - d} \right) C_0 \end{aligned}$$

The minimum VaR standard deviation is

$$\sigma_{mvr} = \sqrt{\frac{1}{d}(c\mu_{mvr}^2 - 2bC_0\mu_{mvr} + aC_0^2)} = \frac{-z_\alpha}{\sqrt{cz_\alpha^2 - d}} C_0$$

The asset allocation  $\theta$  at the minimum Value at Risk portfolio is calculated by using (2.3), the allocation on the efficient frontier, which results in

$$\theta_{mvr} = \frac{1}{c\sqrt{cz_\alpha^2 - d}} \Sigma^{-1} \left( (\sqrt{cz_\alpha^2 - d} - b)\bar{1} + c\mu \right) C_0$$

The minimum value at risk portfolio is shown in the following figure, which is in the mean-VaR framework.

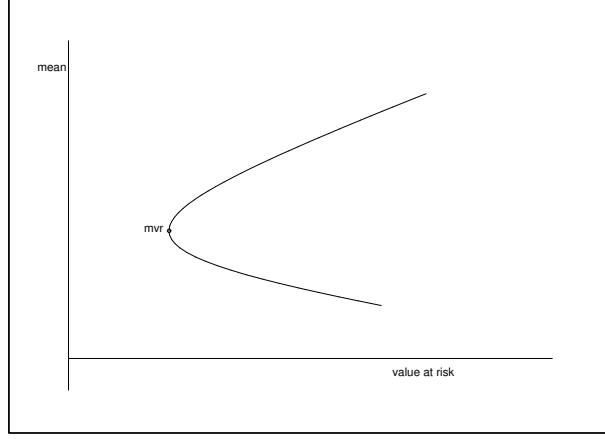

Figure 5.5: The minimum VaR portfolio

### 5.3.2 Tangency VaR portfolio

The tangency VaR portfolio is the portfolio where the line through the origin is tangent to the mean-VaR efficient frontier. It represents the portfolio with maximum ratio mean/VaR, so with maximum value for mean per unit VaR.

At the tangency VaR portfolio, the slope of the tangency line must be the same as the slope of the efficient frontier. So

$$\frac{\Delta VaR_{tvr}}{\Delta \mu_{tvr}} = \left. \frac{\partial VaR_{\alpha}}{\partial \mu_p} \right|_{\mu_p = \mu_{tvr}}$$

Using formula (5.7), we get the following equation

$$\frac{-\mu_{tvr} - z_{\alpha} \sqrt{\frac{1}{d}(c\mu_{tvr}^2 - 2bC_0\mu_{tvr} + aC_0^2)} - 0}{\mu_{tvr} - 0} = -1 - \left. \frac{z_{\alpha}(c\mu_p - bC_0)}{d\sqrt{\frac{1}{d}(c\mu_p^2 - 2bC_0\mu_p + aC_0^2)}} \right|_{\mu_p = \mu_{tvr}}$$

The solution of this equation is

$$\mu_{tvr} = \frac{a}{b}C_0$$

We see that this is the same result as the tangency portfolio in a mean-standard deviation framework! So  $\mu_{tvr} = \mu_{tg}$ . Looking better, it is clear that this result is quite logic. Because

$$Maximize \frac{\mu_p}{VaR_{\alpha}} = Maximize \frac{\mu_p}{-\mu_p - z_{\alpha}\sigma_p} = Minimize \frac{-\mu_p - z_{\alpha}\sigma_p}{\mu_p}$$

$$= \text{Minimize} \frac{-z_\alpha \sigma_p}{\mu_p} = \text{Maximize} \frac{\mu_p}{\sigma_p}$$

the maximization of the tangency line in the mean-VaR framework and the mean-standard deviation framework gives the same result. The corresponding VaR is

$$\text{VaR}_{tg} = -\mu_{tg} - z_\alpha \sigma_{tg} = -\frac{\sqrt{a}}{b}(\sqrt{a} + z_\alpha)C_0$$

and the allocation  $\theta_{tg}$  is the same as the allocation in the mean-standard deviation tangency portfolio.

The portfolio looks like the following in a figure.

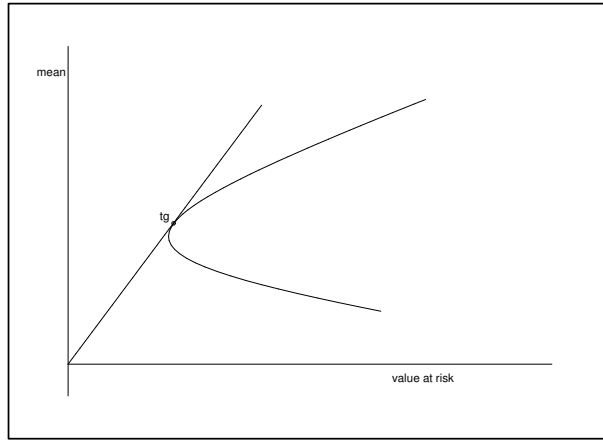

Figure 5.6: The minimum VaR portfolio

### 5.3.3 Telser

We defined the optimal Telser portfolio as the portfolio that maximizes expected return subject to a shortfall constraint. Because the shortfall constraint is a special case of a Value at Risk constraint, we redefine the definition of the optimal Telser portfolio. From now on, the optimal Telser portfolio is the portfolio that maximizes the expected return while satisfying a Value at Risk constraint. If we need the "old version" of the Telser portfolio, we take  $\text{VaR} = C_0$  in the definition. So the Telser problem looks like

$$\text{Max} \left\{ \mu_p \left| \begin{array}{l} \text{VaR}_\alpha \leq \text{VaR}_c \\ \bar{1}^T \theta = C_0 \\ \mu_p = \mu^T \theta \end{array} \right. \right\} \quad (5.12)$$

where  $\text{VaR}_c$  is the maximum allowed Value at Risk of the portfolio. When we assume that returns are distributed elliptically, the first constraint of (5.12) can be rewritten as (use expression (5.1) for the VaR):

$$\begin{aligned} \text{VaR}_\alpha \leq \text{VaR}_c &\iff \text{VaR}_c \geq \text{VaR}_\alpha = -\mu_p - z_\alpha \sigma_p \\ &\iff \mu_p \geq -\text{VaR}_c - z_\alpha \sigma_p \end{aligned}$$

So the optimization problem transforms to

$$Max \left\{ \begin{array}{l} \mu_p \\ \mu_p \geq -VaR_c - z_\alpha \sigma_p \\ \bar{1}^T \theta = C_0 \\ \mu_p = \mu^T \theta \\ \sigma_p^2 = \theta^T \Sigma \theta \end{array} \right\} \quad (5.13)$$

If we take the maximum allowed Value at Risk  $VaR_c$  equal to the starting capital, so  $VaR_c = C_0$ , we exactly get the "old" formulation as described in the Safety First chapter. The corresponding figures for problem (5.13) look like the following, where the optimum lies in area A, and the optimum is found at the maximum expected return, so at point *opt*. The left graph is in mean-standard deviation space, the right graph in mean-VaR space. These two graphs clearly

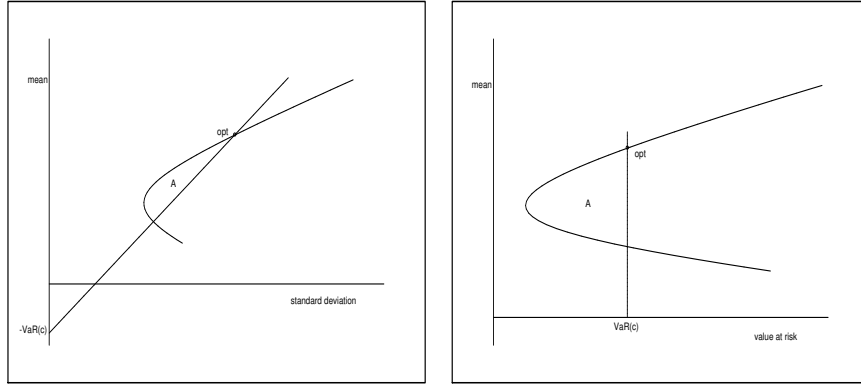

Figure 5.7: The optimal Telser portfolio

show why it is useful to work with the mean-VaR efficient frontier. It is because the Value at Risk constraint becomes a vertical line, which is much easier to work with.

The optimal point is calculated by using the mean-VaR efficient frontier (5.7) with  $VaR_\alpha = VaR_c$ , which gives

$$VaR_c = -\mu_p - z_\alpha \sqrt{\frac{1}{d} (c\mu_p^2 - 2bC_0\mu_p + aC_0^2)}$$

Solving this for  $\mu_p$  results in

$$\mu_{opt} = \frac{bz_\alpha^2 C_0 + dVaR_c - z_\alpha \sqrt{d((a - z_\alpha^2)C_0^2 + 2bVaR_c C_0 + cVaR_c^2)}}{cz_\alpha^2 - d}$$

The corresponding standard deviation is

$$\begin{aligned} \sigma_{opt} &= \left( \frac{-VaR_c - \mu_{opt}}{z_\alpha} \right) \\ &= \frac{z_\alpha (bC_0 + cVaR_c) - \sqrt{d((a - z_\alpha^2)C_0^2 + 2bVaR_c C_0 + cVaR_c^2)}}{d - cz_\alpha^2} \end{aligned}$$

and the Value at Risk equals  $VaR_c$ . The optimal asset allocation  $\theta_{opt}$  is found by using the fact that the optimal portfolio lies on the efficient frontier, so we can use formula (2.3) we derived in the Markowitz chapter:

$$\theta_{opt} = \frac{1}{d} \Sigma^{-1} ((c\mu - b\bar{1})\mu_{opt} + (a\bar{1} - b\mu)C_0)$$

#### 5.3.4 Telser with risk-free asset

If we add a risk-free asset, the efficient frontier changes into the CML. The optimal Telser portfolio with risk-free asset is the portfolio where maximum return is gained, while satisfying the VaR-constraint. In the figures below, we are looking for the highest return in the area  $A$ . This is at point  $opt$ , the point of intersection between the CML and the VaR constraint line.

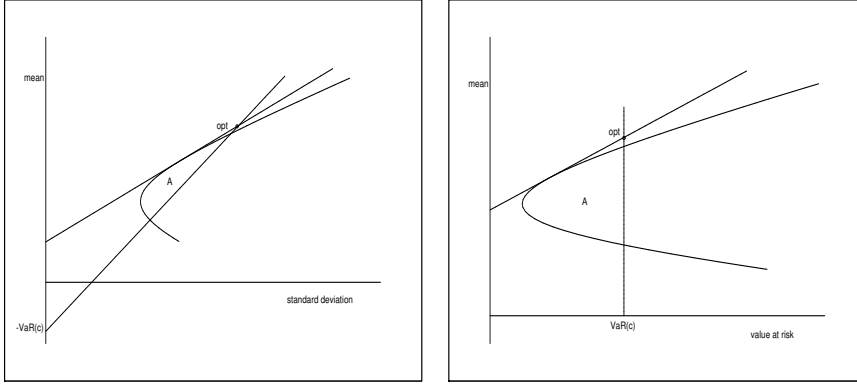

Figure 5.8: The optimal Telser portfolio with risk-free asset

For the calculation of this point of intersection we use the mean-VaR framework, because the VaR constraint line is vertical. Remember the CML is given by (5.10). The point of intersection is at the point where  $VaR_\alpha = VaR_c$ , so

$$\mu_{opt} = \frac{-sVaR_c + C_0z_\alpha\mu_f}{z_\alpha + s}$$

The corresponding standard deviation is

$$\sigma_{opt} = \frac{\mu_{opt} + VaR_c}{-z_\alpha} = -\frac{C_0\mu_f + VaR_c}{z_\alpha + s}$$

and the Value at Risk is  $VaR_c$ . For calculating the optimal asset allocation with risk-free asset, we do the same as we did before in the Markowitz and Telser chapters. The optimal allocation consists of a combination the market portfolio and the risk-free asset. Suppose a fraction  $\Theta_m$  is invested in the market portfolio and a fraction  $\Theta_f$  in the risk-free asset. The two fractions sum to one. Because the returns on the risk-free asset have no standard deviation, the portfolio standard deviation of the optimal portfolio is given by

$$\sigma_{opt} = \sqrt{\Theta_m^2\sigma_m^2 + \Theta_f^2 \cdot 0} = \Theta_m\sigma_m$$

where  $\sigma_m$  is the standard deviation in the market portfolio, derived in the Markowitz chapter. So the fraction invested in this market portfolio is

$$\Theta_m = \frac{\sigma_{opt}}{\sigma_m} = \frac{-\frac{C_0\mu_f + VaR_c}{z_\alpha + s}}{\frac{s}{b - c\mu_f}C_0} = \frac{(C_0\mu_f + VaR_c)(c\mu_f - b)}{s(z_\alpha + s)C_0}$$

So the fraction invested in the risk-free asset is

$$\Theta_f = 1 - \Theta_m = \frac{(a - b\mu_f + sz_\alpha)C_0 + VaR_c(b - c\mu_f)}{s(z_\alpha + s)C_0}$$

where we used that  $s = \sqrt{c\mu_f^2 - 2b\mu_f + a}$ . So the optimal allocation with risk-free asset becomes

$$\theta_{opt} \equiv \begin{pmatrix} \theta_1 \\ \vdots \\ \theta_N \\ \theta_f \end{pmatrix} = \begin{pmatrix} \Theta_m \theta_m \\ \Theta_f C_0 \end{pmatrix} = \begin{pmatrix} \frac{VaR_c + \mu_f C_0}{s(s + z_\alpha)} \Sigma^{-1} (\mu_f \bar{1} - \mu) \\ \frac{(a - b\mu_f + sz_\alpha)C_0 + VaR_c(b - c\mu_f)}{s(z_\alpha + s)} \end{pmatrix}$$

## 5.4 Example

We continue the example of seven securities of the Dutch AEX-index. In the Elliptical Distributions chapter, the optimal Telser portfolio was calculated using the shortfall constraint. This shortfall constraint was a yearly probability of getting in default, and that was the reason why we transformed the daily returns into *yearly* returns. In this chapter we switched to a VaR constraint. But in contrast to the shortfall constraint, the VaR is given for a much shorter period, mostly one day. So the *daily* returns can be used again. The probability  $\alpha$  is also adjusted. The confidence level for the one day VaR that Rabobank is using at the moment is 97,5%, so

$$\alpha = 0.025$$

We will not assume that the daily returns have a normal distribution. Because we have 3609 observations of the daily returns from the 1st of January 1990 till the 31st of October 2003, we can estimate the distributions of the seven securities. We use the quantile-quantile(QQ)-plot for this.

A QQ-plot is useful for comparing a set of data with different distribution functions. The quantiles of the data are plotted against the quantiles of some (elliptical) distribution functions. The data are sort and standardized for each distribution using the mean and standard deviation and these are compared with the quantiles  $k_\alpha$ , where  $\alpha$  is taken from 3609 values in the interval  $[0,1]$ . The best fitting of the distribution of returns for each asset is the plot that is closest to the 45 degrees line, because both quantiles are close to each other there. This results in the QQ-plots at the next pages.

In every plot the normal distribution is shown. It is clear that for none of the securities the normal distribution is a good approximation of the distribution function. Also two or three other elliptical distributions (student-t, Laplace, logistic) are shown, these are the two or three that are closest to the 45 degrees line.

## 5.4. Example

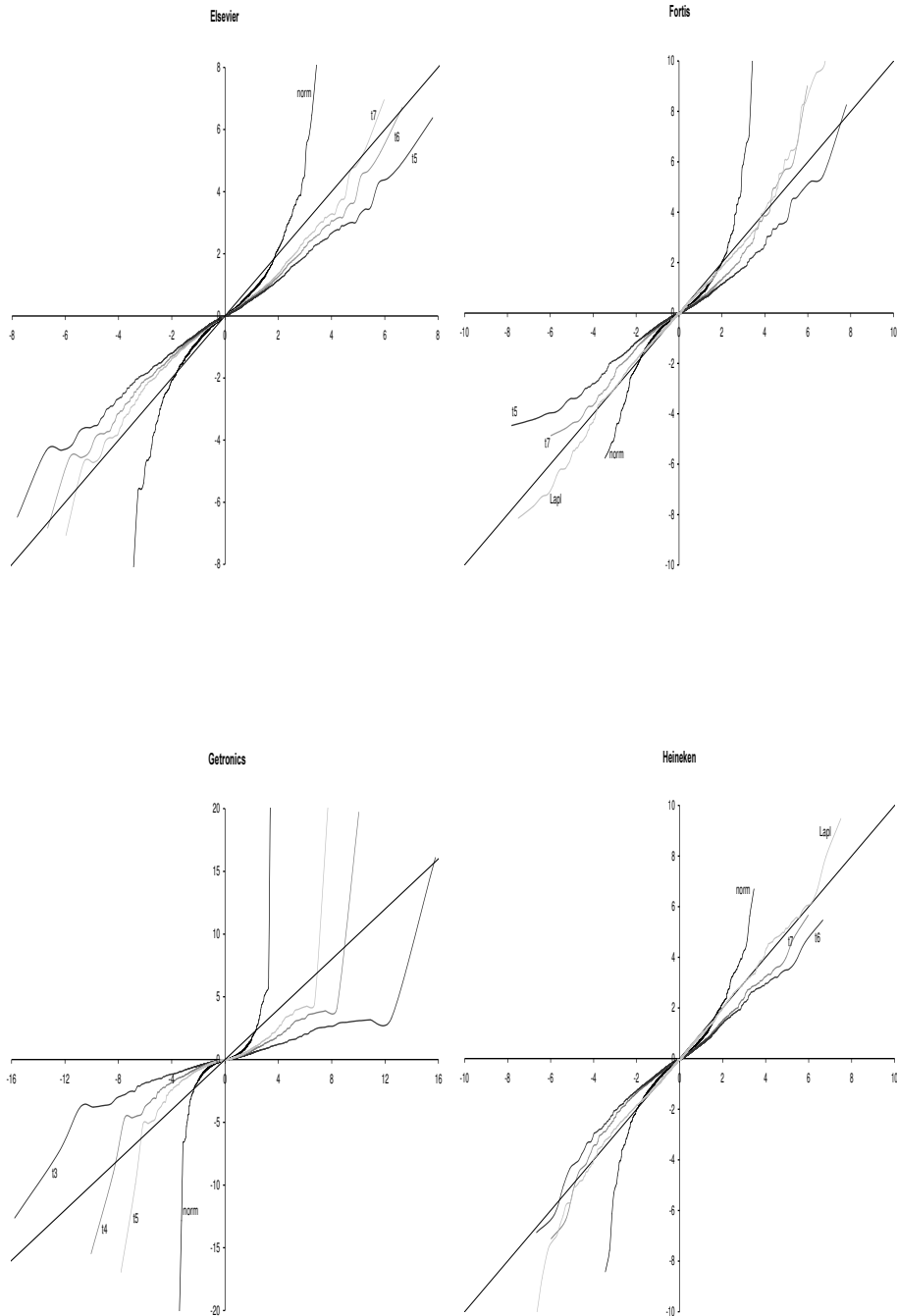

Figure 5.9: QQ-plots of Elsevier, Fortis, Getronics and Heineken.



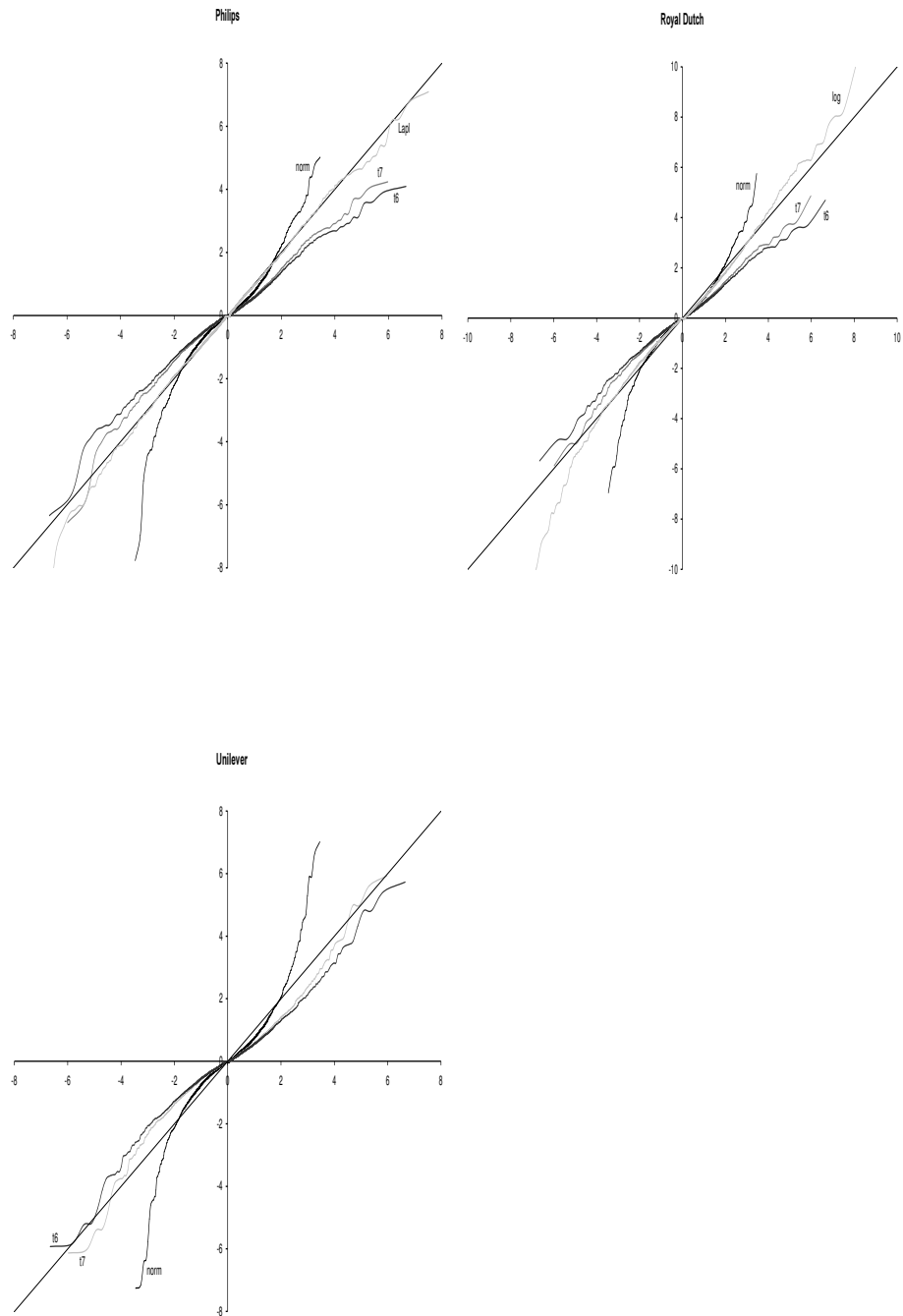

Figure 5.10: QQ-plots of Philips, Royal Dutch and Unilever.

With these plots we can estimate the distributions of the returns. Note that we are only interested in the left tail distribution, because for the VaR constraint we need the 0.025 quantile. By looking at the QQ-plots the following distributions of the left tail can be estimated:

Elsevier	student-t(6)/student-t(7)
Fortis	student-t(7)/Laplace
Getronics	student-t(3)
Heineken	student-t(6)/student-t(7)
Philips	student-t(6)/Laplace
Royal Dutch	student-t(7)
Unilever	student-t(7)/student-t(6)

Table 5.1: Estimated left tail distribution of returns

Notice that Getronics has a difficult elliptical match. The fluctuation in the last years was very high, so the tails are very fat, and there is not an elliptical distribution that really fits. The estimated student-t with 3 parameters of freedom is the closest. But all the others are quite close to each other. Especially the student-t distribution with 6 or 7 degrees of freedom fits for the other six securities. Because a choice for the portfolio distribution has to be made, I choose the student-t distribution with 6 degrees of freedom as the distribution of portfolio returns.

The quantile  $k_\alpha$  of the student-t(6) distribution for  $\alpha = 0.025$  is

$$k_{0.025} = -2.447$$

so the standardized quantile  $z_\alpha$  is

$$z_{0.025} = k_{0.025} \sqrt{\frac{\nu - 2}{\nu}} = -2.447 \sqrt{\frac{6 - 2}{6}} = -1.998$$

Note that this value doesn't differ much from the quantile if returns would be expected to be distributed normally, because then we would have  $z_{0.025} = k_{0.025} = -1.960$ . If we move further to the tail of the distribution, so  $\alpha$  decreases, the difference between the quantiles grows. This is shown in the table below, where the quantiles for different elliptical distributions and different values for  $\alpha$  have been calculated.

	$\alpha = 0.025$		$\alpha = 0.01$		$\alpha = 0.0001$	
	$k_\alpha$	$z_\alpha$	$k_\alpha$	$z_\alpha$	$k_\alpha$	$z_\alpha$
Normal	-1.96	-1.96	-2.33	-2.33	-3.72	-3.72
Student-t(3)	-3.18	-1.84	-4.54	-2.62	-22.20	-12.82
Student-t(4)	-2.78	-1.96	-3.75	-2.65	-13.03	-9.22
Student-t(6)	-2.45	-2.00	-3.14	-2.57	-8.02	-6.55
Student-t(8)	-2.31	-2.00	-2.90	-2.51	-6.44	-5.58
Student-t(10)	-2.23	-1.99	-2.76	-2.47	-5.69	-5.09
Laplace	-3.00	-2.12	-3.91	-2.77	-8.52	-6.02
Logistic	-3.66	-2.02	-4.60	-2.53	-9.21	-5.08

Table 5.2: The quantiles for some elliptical distributions at different  $\alpha$

It is clear that only for extreme low  $\alpha$  it matters what the distribution of returns looks like. If a VaR-confidence level of 97,5% is used, like we do, the results for student-t distributed returns with 4 up to and including 10 degrees of freedom are very close to the normally distributed returns. The same holds for logistic distributed returns.

The mean-VaR efficient frontier is given by

$$\begin{aligned} VaR_\alpha &= -\mu_p - z_\alpha \sqrt{\frac{1}{d} (c\mu_p^2 - 2bC_0\mu_p + aC_0^2)} \\ &= -\mu_p + 1.998 \sqrt{2882.2\mu_p^2 - 1.891\mu_p + 0.435 \times 10^{-3}} \end{aligned}$$

The minimum Value at Risk portfolio has the following coordinates:

$$\begin{aligned} \mu_{mvr} &= \left( \frac{b}{c} + \frac{d}{c\sqrt{cz_\alpha^2 - d}} \right) C_0 = 0.330 \times 10^{-3} \\ VaR_{mvr} &= \left( -\frac{b}{c} + \frac{1}{c} \sqrt{cz_\alpha^2 - d} \right) C_0 = 0.0219 \\ \sigma_{mvr} &= \frac{-z_\alpha}{\sqrt{cz_\alpha^2 - d}} C_0 = 0.0112 \end{aligned}$$

The asset allocation  $\theta_{mvr}$  at the minimum Value at Risk portfolio is

$$\theta_{mvr} = \frac{1}{c\sqrt{cz_\alpha^2 - d}} \Sigma^{-1} \left( (\sqrt{cz_\alpha^2 - d} - b)\bar{1} + c\mu \right) C_0 = \begin{pmatrix} 0.130 \\ -0.004 \\ 0.013 \\ 0.296 \\ -0.009 \\ 0.314 \\ 0.261 \end{pmatrix}$$

which is a quite diversified portfolio.

Suppose the investor has a Value at Risk limit of 10%, so  $VaR_c = 0.1$ . This means that the probability that he loses more than 10 percent of his money is less than  $\alpha = 0.025$ . Then the optimal Telser mean, standard deviation and allocation are

$$\mu_T = \frac{bz_\alpha^2 C_0 + dVaR_c - z_\alpha \sqrt{d((a - z_\alpha^2)C_0^2 + 2bVaR_c C_0 + cVaR_c^2)}}{cz_\alpha^2 - d} = 1.249 \times 10^{-3}$$

$$\sigma_T = \left( \frac{-VaR_c - \mu_T}{z_\alpha} \right) = 0.0507$$

$$\theta_T = \frac{1}{d} \Sigma^{-1} ((c\mu - b\bar{1})\mu_T + (a\bar{1} - b\mu)C_0) = \begin{pmatrix} -0.537 \\ -0.451 \\ -0.238 \\ 3.322 \\ 0.690 \\ -1.147 \\ -0.639 \end{pmatrix}$$

Realize that this value for the VaR is quite high, because the optimal portfolio invests very much in Heineken and goes short in five other securities to generate the amount invested in Heineken. If the investor is more risk averse, so the VaR limit is lower, the following happens. We take  $VaR_c = 0.05$ .

$$\mu_T = 0.753 \times 10^{-3}, \quad \sigma_T = 0.0254, \quad \theta_T = \begin{pmatrix} -0.177 \\ -0.210 \\ -0.102 \\ 1.690 \\ 0.313 \\ -0.359 \\ -0.154 \end{pmatrix}$$

And for  $VaR_c = 0.025$  we have

$$\mu_T = 0.443 \times 10^{-3}, \quad \sigma_T = 0.0127, \quad \theta_T = \begin{pmatrix} 0.048 \\ -0.059 \\ -0.018 \\ 0.667 \\ 0.076 \\ 0.135 \\ 0.150 \end{pmatrix}$$

If the risk-free asset is added, with rate of return  $\mu_f = 0.157 \times 10^{-3}$ , the efficient frontier changes into the CML, which is in mean-VaR space

$$\mu_p = \frac{-s}{z_\alpha + s} VaR_\alpha + \frac{z_\alpha \mu_f}{z_\alpha + s} C_0 = 0.0122 VaR_\alpha + 0.159 \times 10^{-3}$$

The Value at Risk at the market portfolio, for which we have calculated that  $\mu_m = 0.580 \times 10^{-3}$ , is

$$VaR_m = \frac{b\mu_f - a - z_\alpha s}{b - c\mu_f} C_0 = 0.0344$$

The values for the optimal Telser portfolio with risk-free asset are calculated with

$$\mu_T = \frac{-s VaR_c + C_0 z_\alpha \mu_f}{z_\alpha + s}, \quad \sigma_T = -\frac{C_0 \mu_f + VaR_c}{z_\alpha + s}$$

$$\theta_T = \begin{pmatrix} \frac{VaR_c + \mu_f C_0}{s(s + z_\alpha)} \Sigma^{-1} (\mu_f \bar{1} - \mu) \\ \frac{(a - b\mu_f + s z_\alpha) C_0 + VaR_c (b - c\mu_f)}{s(z_\alpha + s)} \end{pmatrix}$$

The results that these formulas give for different values of the VaR limit are given in the following table.

We see that the more risk averse (the lower the VaR) the investor is, the lower the expected return. The standard deviation gets also lower and the amount borrowed at the risk-free rate becomes less. When  $VaR_c = 0.025$ , the investor even lends at the risk-free rate. In the figure below, this is shown by the fact that this optimum lies on the left side of the market portfolio. We also see the minimum VaR portfolio(mvr), market portfolio(m), the efficient frontier(EF), capital market line(CML) and the three Value at Risk constraints.

	$VaR_c = 0.1$	$VaR_c = 0.05$	$VaR_c = 0.025$
$\mu_T$	$1.382 \times 10^{-3}$	$0.770 \times 10^{-3}$	$0.465 \times 10^{-3}$
$\sigma_T$	0.0507	0.0254	0.0127
$\theta_T$	-0.150	-0.075	-0.038
	-0.364	-0.182	-0.091
	-0.159	-0.080	-0.040
	3.241	1.623	0.814
	0.524	0.262	0.132
	-0.242	-0.121	-0.061
$\theta_{r,f}$	0.046	0.023	0.012
	-1.895	-0.450	0.273

Table 5.3: Optimal Telser portfolio results with risk-free asset

## 5.5 References

Artzner, Delbaen, Eber, Heath [1998] *Coherent Measures of Risk*

Carroll, Perry, Yang, Ho [2001] "A New Approach to Component VaR" *Journal of Risk* 3

Di Clemente [2003] *The Empirical Value-at-Risk/Expected Return Frontier: a Useful Tool of Market Risk Managing*

Frei, McNeil [2002] *VaR and Expected Shortfall in Portfolios of Dependent Credit Risks: Conceptual and Practical Insights*

De Giorgi [2002] *A Note on Portfolio Selection under Various Risk Measure*

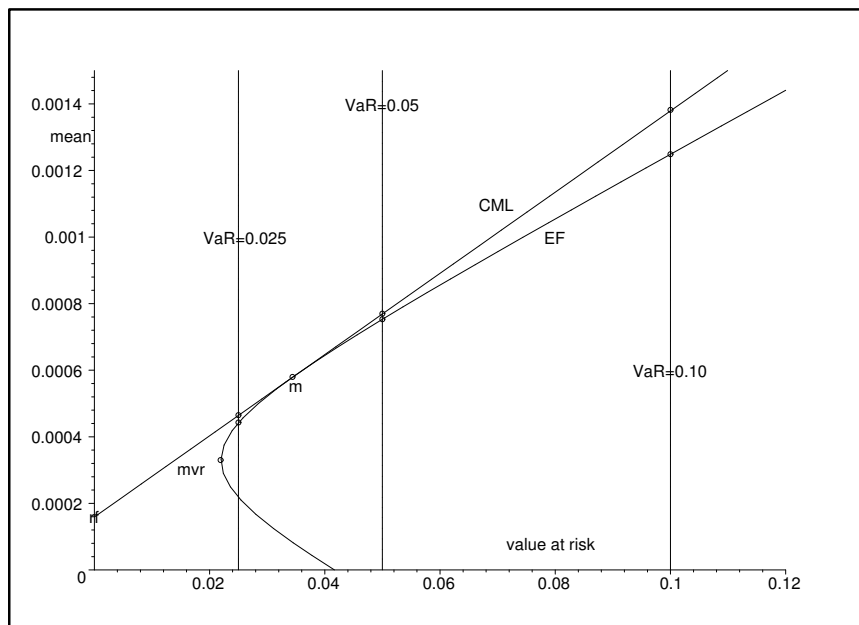

Figure 5.11: Optimal Portfolios with VaR constraint.

- Huisman, Koedijk, Pownall [1999] *Asset Allocation in a Value-at-Risk Framework*
- Hürlimann [2001] *An alternative Approach to Portfolio Selection*
- Lucas [1998] *Nut, Gebruik, en Beperkingen van Value-at-Risk voor Risicomanagement*
- Lucas [1997] *A Note on Optimal Estimation from a Risk Management Perspective under Possibly Mis-specified Tail Behavior*
- Tasche [2000] *Risk Contributions and Performance Measurement*



---

## Maximizing the performance measures EVA and RAROC

---

We have studied optimization problems with different objective functions. In the Markowitz framework, the objective was to maximize the utility function  $u = E(R_p) - \frac{1}{2}\gamma var(R_p)$ . This function appeared to be a convex curve in the mean-standard deviation space. In the Telser framework the objective was to maximize the expected return  $E(R_p)$  subject to some shortfall or Value at Risk constraints. In this chapter we will discuss some models, based on the Telser criterion, but with other objective functions. These objective functions are based on the so called *Economic Value Added* (EVA) and the *Risk Adjusted Return On Capital* (RAROC).

### 6.1 EVA and RAROC

**EVA** The Economic Value Added is defined as follows

$$\text{EVA} = \text{expected portfolio return} - \text{cost of capital}$$

The higher the EVA, the better the performance of the investor. The expected portfolio return is given by  $E(R_p)$ . But because there are costs for keeping capital, the expected return is corrected for this costs. The cost of capital consists of two parameters. It is the cost of capital rate  $r_{cap}$  multiplied by the amount of capital. It is not generally agreed how the amount of capital is defined. There are two main streams: some say the amount of capital is the investors equity capital  $C_0$  (or the allocated capital), some say it is the Value at Risk  $VaR$  (or the consumed capital). Note that the EVA is an absolute



performance measure, because the total cost of capital is subtracted. So it is a nominal amount, not a percentage.

**RAROC** There are numerous different definitions of the RAROC performance measure. The Risk Adjusted Return On Capital we will use in this thesis is defined as

$$\text{RAROC} = \frac{\text{expected portfolio return}}{\text{amount of capital}}$$

The higher the RAROC, the better the investors performance. The maximum RAROC gives the highest expected return, relative to the amount of capital, so RAROC is a relative risk measure. Again, the amount of capital can be defined as the allocated capital  $C_0$ , or the consumed capital  $VaR$ .

The following table shows the performance measures described above:

	allocated capital	consumed capital
EVA	$E(R_p) - r_{cap}C_0$	$E(R_p) - r_{cap}VaR_\alpha$
RAROC	$\frac{E(R_p)}{C_0}$	$\frac{E(R_p)}{VaR_\alpha}$

Table 6.1: Overview of the performance measures EVA and RAROC

The next sections will solve new models based on the EVA and RAROC performance measures.

## 6.2 New Telser models

We have seen four new performance measures in the table above. These four measures can all be implemented in the Telser model with Value at Risk constraint, by setting them as the objective function. We solve the four obtained new Telser models in the next four sections. The fifth section compares some optimal solution with each other.

### 6.2.1 EVA with allocated capital

Using the EVA with allocated capital as the objective function, we get the following optimization problem

$$\text{Max} \left\{ E(R_p) - r_{cap}C_0 \left| \begin{array}{l} E(R_p) = \mu_p = \mu^T \theta \\ P(R_p \leq -VaR_c) \leq \alpha \\ \bar{1}^T \theta = C_0 \end{array} \right. \right\}$$

Because  $r_{cap}C_0$  is a constant, and rewriting the shortfall constraint, this problem is the same as

$$\text{Max} \left\{ \mu_p \left| \begin{array}{l} \mu_p = \mu^T \theta \\ VaR_\alpha \leq VaR_c \\ \bar{1}^T \theta = C_0 \end{array} \right. \right\}$$

which we recognize as the Telser problem of the previous chapter. So the solution is given by

$$\mu_{opt} = \mu_T = \frac{bz_\alpha^2 C_0 + dVaR_c - z_\alpha \sqrt{d((a - z_\alpha^2)C_0^2 + 2bVaR_c C_0 + cVaR_c^2)}}{cz_\alpha^2 - d} \quad (6.1)$$

with corresponding standard deviation

$$\sigma_{opt} = \sigma_T = \frac{z_\alpha(bC_0 + cVaR_c) - \sqrt{d((a - z_\alpha^2)C_0^2 + 2bVaR_c C_0 + cVaR_c^2)}}{d - cz_\alpha^2} \quad (6.2)$$

and the Value at Risk equals  $VaR_c$ . The optimal asset allocation  $\theta_{opt}$  is

$$\theta_{opt} = \theta_T = \frac{1}{d} \Sigma^{-1} ((c\mu - b\bar{1})\mu_T + (a\bar{1} - b\mu)C_0)$$

In the mean-VaR space, the graphical reproduction looks like the following.

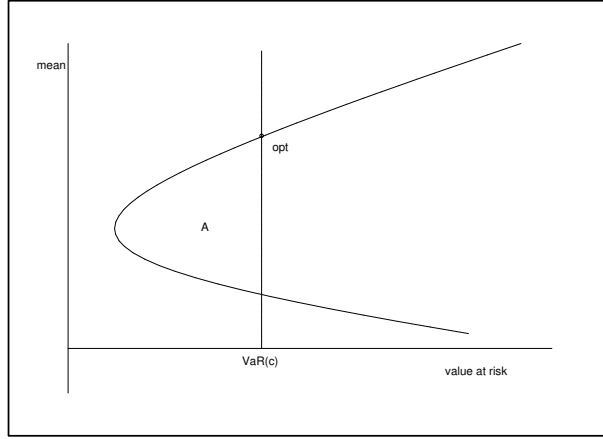

Figure 6.1: Optimal "EVA with allocated capital" portfolio

### 6.2.2 EVA with consumed capital

If the consumed capital is used instead of the allocated capital, in the EVA objective function, the optimization problem becomes

$$\text{Max} \left\{ E(R_p) - r_{cap} VaR_\alpha \left| \begin{array}{l} E(R_p) = \mu_p = \mu^T \theta \\ VaR_\alpha \leq VaR_c \\ \bar{1}^T \theta = C_0 \end{array} \right. \right\}$$

The objective function,  $E(R_p) - r_{cap} VaR_\alpha \equiv u$  is a line in the mean-VaR framework. The line is given by

$$\mu_p = u + r_{cap} VaR_\alpha$$

and maximizing the EVA means maximizing  $u$ , or moving the line as high as possible in the feasible area  $A$ , while keeping the slope coefficient  $r_{cap}$  constant.

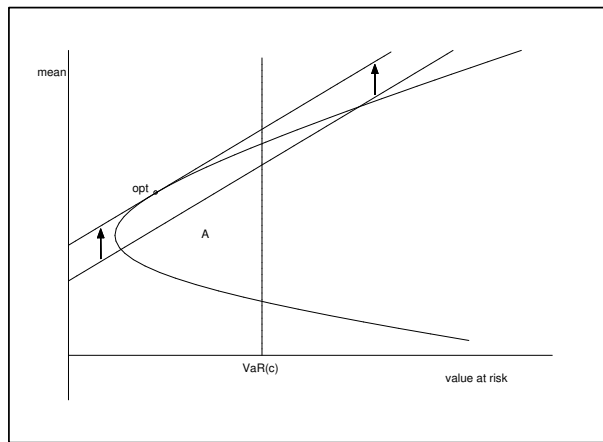

Figure 6.2: Moving the EVA-line with large  $r_{cap}$

We call this line the EVA-line. The feasible area  $A$  is the area between the short-fall line and the efficient frontier. See the figure below for a possible outcome.

Moving the EVA-line as high as possible gives the optimal portfolio  $opt$ . As we can see in the figure, the optimal portfolio differs from the Telser point. In this optimum, the slope of the EVA-line ( $r_{cap}$ ) equals the slope of the efficient frontier. But this optimal portfolio strongly depends on the value for  $r_{cap}$ , the slope of the EVA-line.

If the slope of the EVA-line is much smaller (which means that  $r_{cap}$  is much smaller), we can get the figure below.

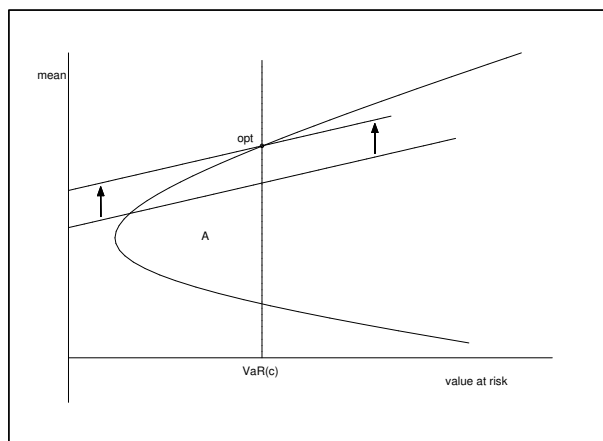

Figure 6.3: Moving the EVA-line with small  $r_{cap}$

Notice the difference from the situation before. Because the feasible area  $A$  is bounded by the shortfall constraint line, the highest EVA-line intersects the efficient frontier at the Telser point, and the optimum is not at the point of

tangency of the efficient frontier and the EVA-line.

So, the optimal allocation is either at the point where the slope of the EVA-line and the efficient frontier are the same (see the first figure, situation 1) or at the Telser point (second figure, situation 2), and it depends on the EVA-line slope,  $r_{cap}$ , in which situation we are. The turning point between the two situations is where the EVA-line is tangent to the efficient frontier, and the tangency point is exactly at the Telser point, which is shown in the figure below.

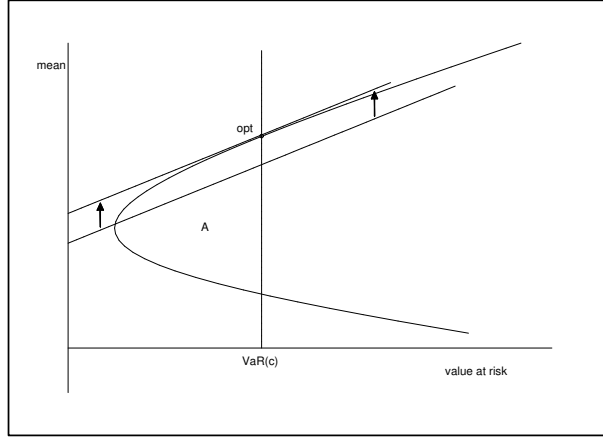

Figure 6.4: The tangency point is the Telser point

We will calculate at which value for  $r_{cap}$  this turning point is reached. Therefore we must equalize the slope of the efficient frontier at the Telser point and the slope of the EVA-line, or

$$\left. \frac{\partial \mu_p}{\partial VaR_\alpha} \right|_{\mu_p = \mu_T} = r_{cap} \iff \left. \frac{\partial VaR_\alpha}{\partial \mu_p} \right|_{\mu_p = \mu_T} = \frac{1}{r_{cap}} \quad (6.3)$$

Remember that the efficient frontier (in mean-VaR space) is given by

$$VaR_\alpha = -\mu_p - z_\alpha \sqrt{\frac{1}{d} (c\mu_p^2 - 2bC_0\mu_p + aC_0^2)}$$

So the derivative of  $VaR_\alpha$  with respect to  $\mu_p$  is given by

$$\frac{\partial VaR_\alpha}{\partial \mu_p} = -1 - \frac{z_\alpha (c\mu_p - bC_0)}{d\sqrt{\frac{1}{d} (c\mu_p^2 - 2bC_0\mu_p + aC_0^2)}} = \frac{-d\sigma_p - z_\alpha (c\mu_p - bC_0)}{d\sigma_p}$$

Using this derivative in (6.3) and solving for  $r_{cap}$ , we get

$$r_{cap} = \frac{d\sigma_T}{-d\sigma_T - z_\alpha (c\mu_T - bC_0)} \equiv r_{cap}^*$$

where  $\mu_T$  and  $\sigma_T$  are the mean and standard deviation at the Telser point, given by (6.1) and (6.2) respectively. So we have situation 1 if  $r_{cap} > r_{cap}^*$ , and situation 2 if  $r_{cap} \leq r_{cap}^*$ .

We will derive the optimal values. The optimum in situation 2 is the Telser portfolio, which is already calculated. Let us calculate the optimum in situation 1. In the optimum (see the first figure), the (inverse of the) slope of the efficient frontier equals (the inverse of)  $r_{cap}$ , for which  $r_{cap} > r_{cap}^*$ . So

$$\begin{aligned} \frac{\partial VaR_\alpha}{\partial \mu_p} &= \frac{1}{r_{cap}} \\ -1 - \frac{z_\alpha(c\mu_p - bC_0)}{d\sqrt{\frac{1}{d}(c\mu_p^2 - 2bC_0\mu_p + aC_0^2)}} &= \frac{1}{r_{cap}} \end{aligned} \quad (6.4)$$

Solving this for  $\mu_p$  gives (after isolating, taking squares and solving the quadratic problem),

$$\mu_{opt} = \left( b + \frac{d}{\sqrt{cK^2 - d}} \right) \frac{1}{c} C_0$$

where  $K$  is a constant defined by  $K = \frac{z_\alpha r_{cap}}{r_{cap} + 1}$ . Notice that  $K < 0$ . This result can be achieved also by noticing that (6.4) can be written as

$$-1 - \frac{1}{r_{cap}} - \frac{z_\alpha(c\mu_p - bC_0)}{d\sqrt{\frac{1}{d}(c\mu_p^2 - 2bC_0\mu_p + aC_0^2)}} = 0$$

If we divide this by  $\frac{r_{cap} + 1}{r_{cap}}$ , we get

$$-1 - \frac{\frac{z_\alpha r_{cap}}{r_{cap} + 1}(c\mu_p - bC_0)}{d\sqrt{\frac{1}{d}(c\mu_p^2 - 2bC_0\mu_p + aC_0^2)}} = -1 - \frac{K(c\mu_p - bC_0)}{d\sqrt{\frac{1}{d}(c\mu_p^2 - 2bC_0\mu_p + aC_0^2)}} = 0$$

This is the same expression as formula (5.11) in the minimum Value at Risk section, with the difference that  $z_\alpha$  is replaced by  $K$ . So the solution of (6.4) is given by the solution  $\mu_{mvr}$  of (5.11), with  $z_\alpha$  replaced by  $K$ . This gives the same optimal mean as derived above.

The corresponding  $\sigma_{opt}$  is

$$\sigma_{opt} = \sqrt{\frac{1}{d}(c\mu_{opt}^2 - 2bC_0\mu_{opt} + aC_0^2)} = \frac{-K}{\sqrt{cK^2 - d}} C_0$$

and the Value at Risk equals

$$VaR_\alpha = -\mu_{opt} - z_\alpha \sigma_{opt} = \left( -\frac{b}{c} + \frac{cz_\alpha K - d}{c\sqrt{cK^2 - d}} \right) C_0$$

which concludes the optimal portfolio in situation 1.

Summarized we can say the following for the optimal  $\mu_p$  when the objective is to maximize the EVA with consumed capital:

$$\mu_{opt} = \begin{cases} \left( b + \frac{d}{\sqrt{cK^2 - d}} \right) \frac{1}{c} C_0 & \text{if } r_{cap} > r_{cap}^* \\ \mu_T & \text{if } r_{cap} \leq r_{cap}^* \end{cases} \quad \text{with } K = \frac{z_\alpha r_{cap}}{r_{cap} + 1}$$

where  $\mu_T$ , the Telser mean, is given by (6.1). The corresponding optimal allocation  $\theta_{opt}$  is on the efficient frontier:

$$\theta_{opt} = \frac{1}{d} \Sigma^{-1} ((c\mu - b\bar{1})\mu_{opt} + (a\bar{1} - b\mu)C_0)$$

### 6.2.3 RAROC with allocated capital

We leave the EVA-based objective function and start looking at the RAROC-based objective. First we look at the case where we deal with allocated capital. The RAROC maximizing optimization problem becomes

$$\text{Max} \left\{ \frac{E(R_p)}{C_0} \left| \begin{array}{l} E(R_p) = \mu^T \theta \\ P(R_p \leq -VaR_c) \leq \alpha \\ \bar{1}^T \theta = C_0 \end{array} \right. \right\}$$

Because  $C_0$  is a constant, and rewriting the shortfall constraint, this problem is the same as

$$\text{Max} \left\{ \mu_p \left| \begin{array}{l} \mu_p = \mu^T \theta \\ VaR_\alpha \leq VaR_c \\ \bar{1}^T \theta = C_0 \end{array} \right. \right\}$$

which is identical to the Telser problem and the EVA optimization problem with allocated capital. So the solutions of this problem are the same as the solutions in the EVA allocated capital section.

### 6.2.4 RAROC with consumed capital

The RAROC optimization problem when we are dealing with consumed capital is

$$\text{Max} \left\{ \frac{E(R_p)}{VaR_\alpha} \left| \begin{array}{l} E(R_p) = \mu_p = \mu^T \theta \\ VaR_\alpha \leq VaR_c \\ \bar{1}^T \theta = C_0 \end{array} \right. \right\}$$

The objective function  $\frac{\mu_p}{VaR_\alpha} \equiv u$  can be written as the RAROC-line

$$\mu_p = u VaR_\alpha$$

so maximizing the RAROC corresponds with finding the maximum slope  $u$  of the line through the origin, which still has overlap with the feasible area  $A$ .

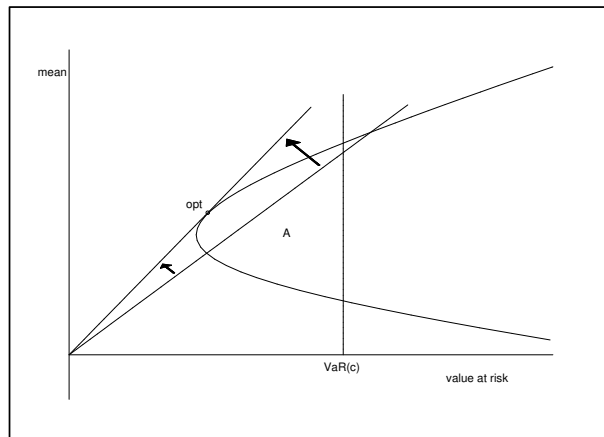

Figure 6.5: Maximizing the slope of the RAROC-line

We see that the optimum is the tangency point in the mean-VaR framework, as defined in the previous chapter. Remember that this is the same tangency point as in the mean-standard deviation framework. This means that

$$\mu_{opt} = \frac{a}{b}C_0, \quad \sigma_{opt} = \frac{\sqrt{a}}{b}C_0, \quad VaR_\alpha = -\frac{\sqrt{a}}{b}(\sqrt{a} + z_\alpha)C_0$$

Note that there can occur a problem if the tangency value for  $VaR_\alpha$ ,  $-\frac{\sqrt{a}}{b}(\sqrt{a} + z_\alpha)C_0$ , is on the right side of the shortfall line  $VaR_c$ . Then the tangency  $VaR_\alpha$  is not in the feasible area  $A$ . Thus we have to reduce the slope of the RAROC-line till it touches the feasible area. Then the optimum moves to the Telser point, as can be seen in the figure below. So we can summarize it as follows:

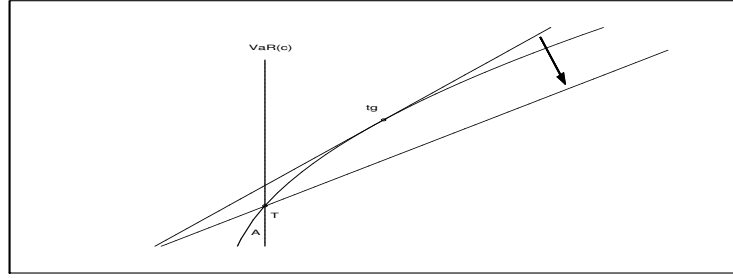

Figure 6.6: The situation if the tangency Value at Risk exceeds  $VaR_c$

$$\mu_{opt} = \begin{cases} \mu_T & \text{if } VaR_c < -\frac{\sqrt{a}}{b}(\sqrt{a} + z_\alpha)C_0 \\ \mu_{tg} & \text{if } VaR_c \geq -\frac{\sqrt{a}}{b}(\sqrt{a} + z_\alpha)C_0 \end{cases}$$

and again the corresponding optimal allocation  $\theta_{opt}$  is on the efficient frontier:

$$\theta_{opt} = \frac{1}{d}\Sigma^{-1}((c\mu - b\bar{1})\mu_{opt} + (a\bar{1} - b\mu)C_0)$$

### 6.2.5 Comparison EVA-RAROC

A simple comparison can be made between the EVA and RAROC performance measures. We already have seen that the EVA is a nominal amount and the RAROC is a percentage. But what is the relationship between the optima?

If allocated capital is used, the optimal portfolios are the same because they both are the optimal Telser portfolio. It is more interesting to look at the case where consumed capital is used. We discuss four situations.

**Situation 1** Suppose that

$$r_{cap} \leq r_{cap}^* \quad \text{and} \quad VaR_c \leq -\frac{\sqrt{a}}{b}(\sqrt{a} + z_\alpha)C_0.$$

Then in both situations the Telser portfolio is optimal, so the optimum with the EVA performance measure is identical to the optimum with the RAROC performance measure. We write  $\mu_{opt}^{EVA} = \mu_{opt}^{RAROC}$ .

**Situation 2** This changes when the following situation appears:

$$r_{cap} \leq r_{cap}^* \quad \text{and} \quad VaR_c > -\frac{\sqrt{a}}{b}(\sqrt{a} + z_\alpha)C_0.$$

Then the optimal EVA portfolio remains the Telser optimum, but the RAROC maximizing portfolio changes into the tangency portfolio. So in this case we have that  $\mu_{opt}^{EVA} > \mu_{opt}^{RAROC}$ .

**Situation 3** The third possible situation is that

$$r_{cap} > r_{cap}^* \quad \text{and} \quad VaR_c \leq -\frac{\sqrt{a}}{b}(\sqrt{a} + z_\alpha)C_0.$$

In this case, the EVA maximizing portfolio is smaller than the Telser portfolio, which is the optimal RAROC portfolio, so  $\mu_{opt}^{EVA} < \mu_{opt}^{RAROC}$ .

**Situation 4** The last possibility is that the following occurs:

$$r_{cap} > r_{cap}^* \quad \text{and} \quad VaR_c > -\frac{\sqrt{a}}{b}(\sqrt{a} + z_\alpha)C_0.$$

Now we have that

$$\mu_{opt}^{EVA} = \left( b + \frac{d}{\sqrt{cK^2 - d}} \right) \frac{1}{c} C_0, \quad \mu_{opt}^{RAROC} = \frac{a}{b} C_0$$

We calculate for which value of  $r_{cap}$  these two optima are the same. Then

$$\left( b + \frac{d}{\sqrt{cK^2 - d}} \right) \frac{1}{c} C_0 = \frac{a}{b} C_0$$

which results in the easy expression

$$K = -\sqrt{a}$$

Because  $K = \frac{z_\alpha r_{cap}}{r_{cap} + 1}$ , we see after a little calculation that

$$r_{cap} = \frac{-\sqrt{a}}{z_\alpha + \sqrt{a}}$$

So if the cost of capital rate equals this value, we have that  $\mu_{opt}^{EVA} = \mu_{opt}^{RAROC}$ . If the value for  $r_{cap}$  is smaller, the EVA line gets a smaller slope, so the optimal EVA mean moves to the right. In the other way, if  $r_{cap}$  is greater the optimum moves to the left. Concluding we can say the following for this fourth situation:

$$\begin{cases} \mu_{opt}^{EVA} < \mu_{opt}^{RAROC} & \text{if } r_{cap} > \frac{-\sqrt{a}}{z_\alpha + \sqrt{a}} \\ \mu_{opt}^{EVA} = \mu_{opt}^{RAROC} & \text{if } r_{cap} = \frac{-\sqrt{a}}{z_\alpha + \sqrt{a}} \\ \mu_{opt}^{EVA} > \mu_{opt}^{RAROC} & \text{if } r_{cap} < \frac{-\sqrt{a}}{z_\alpha + \sqrt{a}} \end{cases}$$

Remember that in any case we must have in this situation that  $r_{cap} > r_{cap}^*$ .



### 6.3 Models with risk-free asset

Like with most models, we can add the risk-free asset with constant rate of return  $\mu_f$ . Remember that the efficient frontier changes in the capital market line, which is given by

$$\mu_p = \frac{-s}{z_\alpha + s} VaR_\alpha + \frac{z_\alpha \mu_f}{z_\alpha + s} C_0 \quad \text{with } s = \sqrt{c\mu_f^2 - 2b\mu_f + a}$$

when we are working in the mean-VaR space.

#### 6.3.1 EVA

For maximizing the EVA, when dealing with *allocated* capital, we can handle the same as in the previous section without risk-free asset. Because the allocated capital is a constant, the EVA-maximization problem

$$Max \left\{ E(R_p) - r_{cap} C_0 \left| \begin{array}{l} E(R_p) = \mu_p = \mu^T \theta + \mu_f \theta_f \\ P(R_p \leq -VaR_c) \leq \alpha \\ \bar{1}^T \theta + \theta_f = C_0 \end{array} \right. \right\}$$

can be written as

$$Max \left\{ \mu_p \left| \begin{array}{l} \mu_p = \mu^T \theta + \mu_f \theta_f \\ VaR_\alpha \leq VaR_c \\ \bar{1}^T \theta + \theta_f = C_0 \end{array} \right. \right\}$$

which solution is exactly the optimal Telser portfolio, as calculated in the previous chapter. See also the left figure below for a graphical view of the problem and solution. The optimal values are

$$\mu_{opt} = \frac{-s VaR_c + C_0 z_\alpha \mu_f}{z_\alpha + s}, \quad \sigma_{opt} = -\frac{C_0 \mu_f + VaR_c}{z_\alpha + s}, \quad VaR_\alpha = VaR_c$$

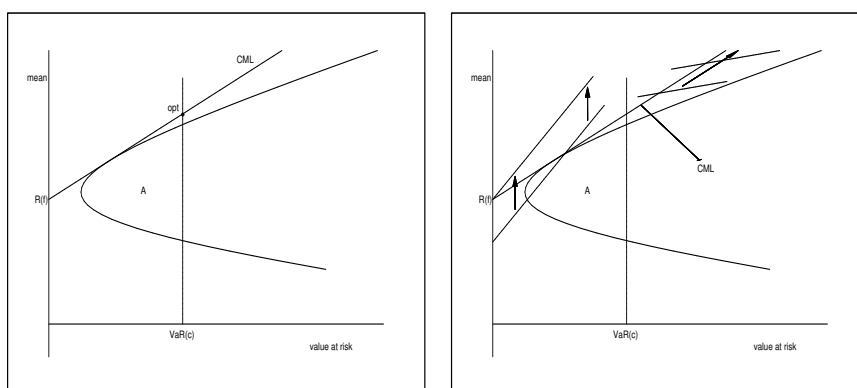

Figure 6.7: EVA maximization solutions with risk-free asset

If the EVA performance measure deals with *consumed* capital, the problem changes. The solution of the problem

$$Max \left\{ E(R_p) - r_{cap} VaR_\alpha \left| \begin{array}{l} E(R_p) = \mu_p = \mu^T \theta + \mu_f \theta_f \\ VaR_\alpha \leq VaR_c \\ \bar{1}^T \theta + \theta_f = C_0 \end{array} \right. \right\}$$

again is finding the maximum  $u$  in the EVA-line

$$\mu_p = u + r_{cap}VaR_\alpha$$

with slope  $r_{cap}$ . But because the efficient frontier is the CML (with slope  $\frac{-s}{z_\alpha+s}$  in the mean-VaR space), we see in the right figure above that there are three possibilities. If the slope of the EVA-line is greater than the CML slope, the highest EVA-line starts at the risk-free point, which will be the optimum. If the slope of the CML is greater than the EVA-line slope, the EVA-line will move up till it reaches the Telsler portfolio, which will be the optimum. If the two slopes are identical, every point on the CML is optimal, as long as it stays on the left side of the VaR-constraint line.

It is clear that this situation of maximizing the Economic Value Added with consumed capital and risk-free asset is not really useful, because the optimal point is either at the left extremum (investing everything in the risk-free asset) or it is the Telsler portfolio. Thus when there exists a risk-free asset, the EVA performance measure is not a suitable objective function.

### 6.3.2 RAROC

For the RAROC maximization problem with *allocated* capital and risk-free asset, we get the same result as with the EVA performance measure with allocated capital. Because the maximization of  $E(R_p)/C_0$  (with  $C_0$  a constant) is the same as the maximization of  $E(R_p)$ , finding the optimum is exactly the Telsler problem with risk-free asset. So the optimal point is the point in the feasible area with maximum expected return, which is the point of intersection of the CML and the VaR-constraint line. This is shown in the left figure below.

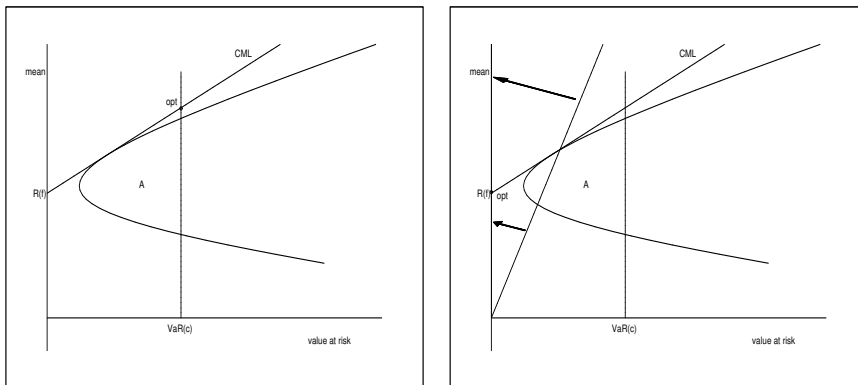

Figure 6.8: RAROC maximization solutions with risk-free asset

If we deal with *consumed* capital, the solution is different. We know that maximizing the ratio  $E(R_p)/VaR_\alpha$  means finding the greatest slope of the line through the origin (we call it the RAROC-line), which still lies in the feasible area. But, as the right figure below shows, we can rotate the RAROC-line until it reaches the risk-free point. Notice that it does not stop at the tangency point, as was the case in the situation without risk-free asset. Because the Value at Risk goes to zero when moving to the risk-free point, the RAROC ratio tends

to infinity. So when the risk-free asset is involved, the RAROC with consumed capital can go to infinity if everything is invested in the risk-free asset, so this performance measure is not realistic.

Summarized we can say that, if the risk-free asset is added, both the EVA and RAROC performance measure give the Telser portfolio (with risk-free asset) as the optimal portfolio if we deal with allocated capital. But if the consumed capital is used for the performance measures, the optimal solutions are either the risk-free portfolio or the Telser portfolio.

## 6.4 Example

We continue our example. Suppose that the portfolio return is distributed according to a student-t(6) distribution, like we did in the previous chapter, so the standardized quantile, where the Value-at-Risk confidence level is taken 97,5%, is

$$z_{0.025} = -1.998$$

The cost of capital rate within Rabobank is 10% per year. Because we are working in a daily context, we take

$$r_{cap} = 1 - (0.90)^{(1/250)} = 0.421 \times 10^{-3}$$

In this example we allow a maximum Value at Risk of 0.05, so

$$VaR_c = 0.05$$

The EVA allocated capital problem gives the Telser portfolio of the previous chapter (with  $VaR_c = 0.05$ ) as the optimum. These optimal values are

$$\mu_T = 0.753 \times 10^{-3}, \quad \sigma_T = 0.0254, \quad \theta_T = \begin{pmatrix} -0.177 \\ -0.210 \\ -0.102 \\ 1.690 \\ 0.313 \\ -0.359 \\ -0.154 \end{pmatrix}$$

and the optimum is given by point  $s$  in the figure. If we deal with consumed capital, the optimum changes. We calculate  $r_{cap}^*$  to see which formula gives the optimum.

$$r_{cap}^* = \frac{d\sigma_T}{-d\sigma_T - z_\alpha(c\mu_T - bC_0)} = 0.0105 > r_{cap}$$

Because  $r_{cap} < r_{cap}^*$ , also in this case the optimum is the Telser portfolio with results as above. Again this is point  $s$  in the figure.

If the objective is to maximize the RAROC, the result when using the allocated capital is again the Telser portfolio ( $s$  in the figure). If the consumed capital is used, we have to determine the tangency VaR. This is

$$VaR_{tg} = -\frac{\sqrt{a}}{b}(\sqrt{a} + z_\alpha)C_0 = 0.0259 < VaR_c$$

So because  $VaR_c > -\frac{\sqrt{a}}{b}(\sqrt{a} + z_\alpha)C_0$ , the optimal portfolio is given by

$$\left\{ \begin{array}{l} \mu_{opt} = \frac{a}{b}C_0 = 0.596 \times 10^{-3} \\ \sigma_{opt} = \frac{\sqrt{a}}{b}C_0 = 0.0132 \\ VaR_\alpha = -\frac{\sqrt{a}}{b}(\sqrt{a} + z_\alpha)C_0 = 0.0259 \\ \theta_{opt} = \frac{1}{a}\Sigma^{-1}((c\mu - b\bar{1})\mu_{opt} + (a\bar{1} - b\mu)C_0) = \begin{pmatrix} 0.036 \\ -0.067 \\ -0.022 \\ 0.723 \\ 0.089 \\ 0.108 \\ 0.134 \end{pmatrix} \end{array} \right.$$

This is point  $q$  in the figure. In the figure we see that the slope of the EVA-line is quite small. We can calculate what the  $r_{cap}$  has to be if we want the optimal EVA portfolio with consumed capital to be the same as when the consumed RAROC is used. The we must have that

$$r_{cap} = \frac{-\sqrt{a}}{z_\alpha + \sqrt{a}} = 0.0177$$

at a daily basis, which means a value of

$$r_{cap} = 1 - (1 - 0.0177)^{250} = 0.989$$

per year. So if the cost of capital rate is 98.9%, the two optima are equal to each other. This is an extraordinary high value which will not happen in reality.

If the risk-free asset is added, the solutions for the objectives that deal with consumed capital become either the portfolio that consists only of the risk-free asset or the Telser portfolio. In the EVA case, the Telser portfolio is the result, while in the RAROC case it results in the risk-free portfolio (which gives infinite RAROC). The optimal portfolios with allocated capital are simply the Telser portfolios with risk-free asset, which we have seen in the previous chapter. The solution is given by

$$\mu_T = 0.770 \times 10^{-3}, \quad \sigma_T = 0.0254, \quad \theta_T = \begin{pmatrix} -0.075 \\ -0.182 \\ -0.080 \\ 1.623 \\ 0.262 \\ -0.121 \\ 0.023 \\ -0.450 \end{pmatrix}$$

In the figure, this portfolio is represented by point  $r$ . Also shown in the figure are the efficient frontier(EF), capital market line(CML), Value at Risk line, EVA line, and the RAROC line.

## 6.5 References

Baud, Frachot, Iggibel, Martineau, Roncalli [1999] *An Analysis Framework for Bank Capital Allocation*

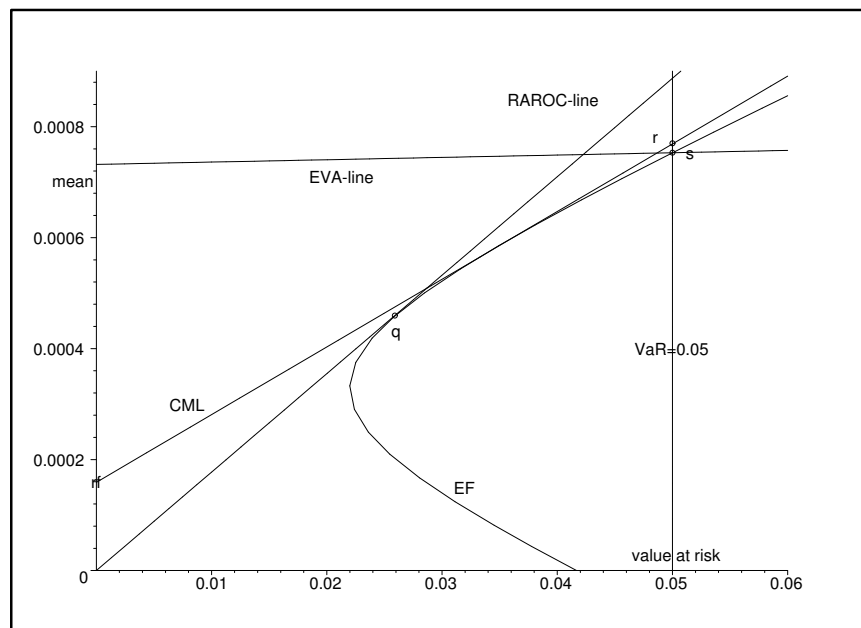

Figure 6.9: Optimal EVA and RAROC portfolios.

Bralver, Kuritzkes [19??] "Risk Adjusted Performance Measurement in the Trading Room" *Journal of Applied Corporate Finance*

Jameson [2001] "Between Raroc and a Hard Place" *ERisk.com*

Punjabi [1998] "Many Happy Returns" *Risk Magazine* June

Rabobank Nederland [2003] *Economic Capital from a Conceptual Point of View*. Internal Memo.

Smithson [2001] "Allocating and Optimising Capital" *Risk Magazine* June

Wilson [1992] "Raroc Remodelled" *Risk Magazine* September

---

# Modeling uncertainty of input parameters

---

This chapter deals with the role of parameter uncertainty in the models we have described. It shows what happens if the chosen parameters  $\mu$  and  $\Sigma$  are not certain. This is because in reality, it is very difficult to estimate the correct values of these parameters and these correct values change every day.

## 7.1 Overview

There are several techniques proposed in the literature to handle this parameter uncertainty. Basic thought is to reduce the sensitivity of the optimal portfolios to input uncertainty. In other words, if the input parameters  $\mu$  and  $\Sigma$  change a small amount, the optimal portfolio should not change much.

Frost and Savarino propose to constrain the portfolio weights, so one single asset doesn't become too important for the portfolio. Chopra et al. proposes to use a James-Stein Estimator for means, while Black and Litterman suggest Bayesian estimation of means and covariances. Jorion researches the Bayes-Stein estimators. There are also sample-based and scenario-based approaches, as described in papers of Michaud and Ziemba et al. All these methods reduce the sensitivity of the portfolio allocation to the input parameters, but do not provide any hard guarantees on the portfolio performance.

A proposal to model parameter uncertainty in this thesis is as follows. It arose after many discussions with statisticians and econometricians within Rabobank. We define a probability distribution function for the uncertain parameters  $\mu$  and  $\Sigma$ , and include this in the optimization problem. The objective function, which is the expected return in the Telser framework, now has to deal

not only with uncertainty of the returns, which is given by  $\mu$  and  $\sigma$ , but also with uncertainty in these last two parameters. So the uncertainty parameters are uncertain, and a 'second layer' uncertainty is created. This must result in a new simultaneous distribution of portfolio returns, which depends asset returns, means and covariances. There are some difficulties with this method. First the distribution functions of  $\mu$  and  $\Sigma$  are very difficult to determine. Second, if these distribution functions are determined, the new simultaneous distribution function is even more difficult to find. After this, the optimization has to be executed with this new simultaneous distribution function which probably will not be elliptical, which seems to be a hopeless task. Besides this, this method still doesn't provide any hard guarantees on the portfolio performance.

That is why, throughout this thesis, I will discuss another approach. The input parameters  $\mu$  and  $\sigma$  are expected to lie within a confidence interval, and the optimization problem will be solved for the *worst case* scenario. The confidence interval is called the uncertainty set. This means that, for example if we work with a Value at Risk constraint, in none of the possible input situations the portfolio VaR will exceed the VaR limit. So the investor is guaranteed a certain portfolio return, because the worst-case situation is optimized. In the literature this robust optimization is considered by for instance Ben-Tal and Neriowski, and Goldfarb and Iyengar.

## 7.2 Uncertainty sets

Suppose an investor doesn't know the exact values for the mean return vector and covariance matrix, but that he knows a certain interval the parameters are lying in. The intervals are bounded by a lower bound and an upper bound, so we can write

$$\begin{aligned}\mu_i^L &\leq \mu_i \leq \mu_i^U & \forall i \\ \sigma_{ij}^L &\leq \sigma_{ij} \leq \sigma_{ij}^U & \forall i, j\end{aligned}$$

Instead of using the above notation we will use, with  $\mu_i^0 = (\mu_i^L + \mu_i^U)/2$ ,  $\beta_i = (\mu_i^U - \mu_i^L)/2$ ,  $\sigma_{ij}^0 = (\sigma_{ij}^L + \sigma_{ij}^U)/2$  and  $\delta_{ij} = (\sigma_{ij}^U - \sigma_{ij}^L)/2$ , the following:

$$\begin{aligned}\mu_i^0 - \beta_i &\leq \mu_i \leq \mu_i^0 + \beta_i & \forall i \\ \sigma_{ij}^0 - \delta_{ij} &\leq \sigma_{ij} \leq \sigma_{ij}^0 + \delta_{ij} & \forall i, j\end{aligned}$$

So the uncertainty sets of the mean return  $S_m$  and the covariance  $S_v$  can be written as

$$S_m = \{\mu : \mu^0 - \beta \leq \mu \leq \mu^0 + \beta, \beta \geq 0\} \quad (7.1)$$

$$S_v = \{\Sigma : \Sigma^0 - \Delta \leq \Sigma \leq \Sigma^0 + \Delta, \Delta \geq 0\} \quad (7.2)$$

These are the uncertainty sets we will use in this chapter.

## 7.3 Second order cone programming

The optimal values for the Markowitz and Telser portfolios (without parameter uncertainty) in the previous chapters were explicit expressions, obtained by using either Lagrange's method or the Kuhn-Tucker conditions. So far, it is

not possible to find an explicit expression for the optimal values when we are considering the worst case outcomes for the uncertain parameters. Instead, we will be able to reduce the problems to a *second order cone problem* (SOCP), which can be solved fast using a computer. A SOCP is an optimization problem of the following form:

$$\text{Min } \{ f^T x \mid \|A_i x + b_i\| \leq c_i^T x + d_i, \quad i = 1, \dots, N \} \quad (7.3)$$

where  $\|\cdot\|$  is the standard Euclidean norm, so  $\|u\| = \sqrt{u^T u}$  for a vector  $u$ . Vectors  $f$ ,  $x$  and  $c$  are  $n$ -dimensional, while  $x$  is the decision variable. There are  $N$  constraints.

Second order cone programming is a problem class that lies between linear programming and semidefinite programming (SDP). SOCPs can be solved far more efficiently than SDPs, so if a SDP can be written as a SOCP, this is preferred.

The constraints in (7.3) are called second order cone constraints. This has the following reason. Note that the standard second order cone of dimension  $k$  is defined as

$$\mathcal{C}_k = \left\{ \begin{pmatrix} u \\ t \end{pmatrix} \right\} \quad \text{with} \quad \|u\| \leq t \quad (7.4)$$

where  $u$  is a  $(k-1)$ -dimensional vector and  $t$  is a scalar. For example, in the three dimensional space ( $k=3$ ) we have that the formula for the standard second order cone is

$$z \geq \sqrt{x^2 + y^2}$$

which has the following graph:

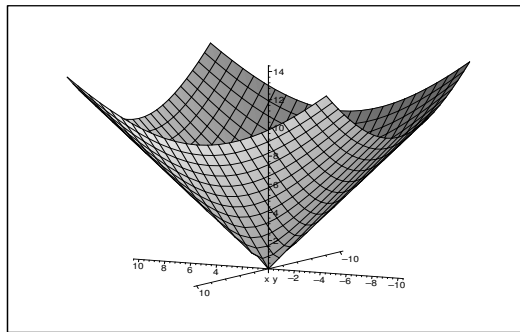

Figure 7.1: The standard second order cone

Now suppose that we have the following set of points

$$\begin{pmatrix} A_i \\ c_i^T \end{pmatrix} x + \begin{pmatrix} b_i \\ d_i \end{pmatrix}$$

with  $A_i$  a  $(k-1) \times n$ -matrix,  $c_i$  and  $b_i$  vectors of  $n$  respectively  $(k-1)$  dimensions, and  $d_i$  a scalar. When this set of points lies in the standard cone of dimension  $k$ , the following must hold

$$\begin{pmatrix} A_i \\ c_i^T \end{pmatrix} x + \begin{pmatrix} b_i \\ d_i \end{pmatrix} \in \mathcal{C}_k \quad \iff \quad \begin{pmatrix} A_i x + b_i \\ c_i^T x + d_i \end{pmatrix} \in \mathcal{C}_k$$



And because of (7.4) we must have

$$\|A_i x + b_i\| \leq c_i^T x + d_i$$

which is the second order cone constraint in (7.3).

A SOCP includes the family of Linear Programs, which can be seen by taking  $A_i$  the zero-matrix and  $b_i$  the zero-vector, so the constraint transforms to the linear constraint  $0 \leq c_i^T x + d_i$ . SOCPs include many more optimization problems, like quadratic programs, problems with hyperbolic constraints and problems involving sums and maxima of norms, which is shown in Lobo et al. (1998).

For solving SOCPs, there are some interior point methods available. This methods are implemented in computer software like SEDUMI and SDPT3. We will use the SEDUMI package, which is an optimizer that uses the power of MATLAB, to solve the problems we will face in the next sections. For making the implementation of SEDUMI in MATLAB easier we use the program Yalmip.

## 7.4 Portfolio optimization and SOCP

In this thesis we have optimized the Markowitz portfolio and the Telser portfolio with a Value at Risk constraint. We used the techniques of Lagrange and Kuhn-Tucker to get an explicit expression for the optimal portfolio's. But these problems can also be written as a SOCP.

### 7.4.1 Markowitz

Remember that the Markowitz optimization problem is

$$Max \{ \mu^T \theta - \frac{1}{2} \gamma \theta^T \Sigma \theta \mid \bar{1}^T \theta = C_0 \}$$

with positive risk-aversion parameter  $\gamma$ . We can rewrite this as

$$Min \{ \theta^T \Sigma \theta - \frac{2}{\gamma} \mu^T \theta \mid \bar{1}^T \theta = C_0 \}$$

and by noticing the following (we add and subtract the same constant and perform some other operations)

$$\begin{aligned} & \theta^T \Sigma \theta - \frac{2}{\gamma} \mu^T \theta \\ &= \left( \Sigma^{1/2} \theta \right)^T \left( \Sigma^{1/2} \theta \right) - \frac{1}{\gamma} \theta^T \Sigma^{1/2} \Sigma^{-1/2} \mu - \frac{1}{\gamma} \mu^T \Sigma^{-1/2} \Sigma^{1/2} \theta \\ & \quad + \left( \frac{1}{\gamma} \Sigma^{-1/2} \mu \right)^T \left( \frac{1}{\gamma} \Sigma^{-1/2} \mu \right) - \left( \frac{1}{\gamma} \Sigma^{-1/2} \mu \right)^T \left( \frac{1}{\gamma} \Sigma^{-1/2} \mu \right) \\ &= \left( \Sigma^{1/2} \theta - \frac{1}{\gamma} \Sigma^{-1/2} \mu \right)^T \left( \Sigma^{1/2} \theta - \frac{1}{\gamma} \Sigma^{-1/2} \mu \right) - \frac{1}{\gamma^2} \mu^T \Sigma^{-1} \mu \\ &= \left\| \Sigma^{1/2} \theta - \frac{1}{\gamma} \Sigma^{-1/2} \mu \right\|^2 - \frac{a}{\gamma^2} \end{aligned}$$

we can write the optimization problem as

$$\text{Min} \left\{ \|\Sigma^{1/2}\theta - \frac{1}{\gamma}\Sigma^{-1/2}\mu\|^2 - \frac{a}{\gamma^2} \mid \bar{1}^T\theta = C_0 \right\}$$

Because, in a SOCP, we must have a linear objective function, we add a variable  $t$  to achieve this, which gives an extra constraint. The result is

$$\text{Min} \left\{ t \mid \begin{array}{l} \|\Sigma^{1/2}\theta - \frac{1}{\gamma}\Sigma^{-1/2}\mu\| \leq t \\ 0 = \bar{1}^T\theta - C_0 \end{array} \right\}$$

which is the SOCP of the form (7.3) belonging to the optimal Markowitz portfolio.

#### 7.4.2 Telser

We do the same with the Telser optimization problem. We have shown before that the Telser problem with elliptically distributed returns, maximum Value at Risk  $VaR_c$  (which implies the constraint  $P(R_p \leq -VaR) \leq \alpha$ ) and corresponding (negative) quantile  $z_\alpha$  can be written as

$$\text{Max} \left\{ \mu^T\theta \mid \begin{array}{l} \mu^T\theta \geq -VaR_c - z_\alpha\sqrt{\theta^T\Sigma\theta} \\ \bar{1}^T\theta = C_0 \end{array} \right\}$$

which is easy to transform in a SOCP. If we use that  $\sqrt{\theta^T\Sigma\theta} = \|\Sigma^{1/2}\theta\|$  we get

$$\text{Min} \left\{ -\mu^T\theta \mid \begin{array}{l} \|\Sigma^{1/2}\theta\| \leq \frac{1}{-z_\alpha}\mu^T\theta + \frac{1}{-z_\alpha}VaR_c \\ 0 = \bar{1}^T\theta - C_0 \end{array} \right\}$$

## 7.5 Portfolio optimization with uncertainty

Let's look at the optimization problem with the uncertainty sets for  $\mu$  and  $\Sigma$ , as described in (7.1) and (7.2) respectively. We have explained that the uncertainty will be handled by evaluating the worst case scenario. But what is the worst case expected return and covariance? If no short sales are allowed (ie. no borrowing), it is clear that the worst case expected return is the minimal expected return, which is the lower bound  $\mu - \beta$ . But in this thesis we allow short sales (borrowing), so this is not sufficient. If an investor goes short in an asset, the worst case expected return for that asset is the highest possible return, because this costs the investor the most money. Then we have to deal with the highest expected return for this asset, or the upper bound  $\mu_i + \beta_i$ . For the covariances we can use the same reasoning. Concluding we can say that it depends on the investment policy if we have to use the upper or lower bound for both the expected return and covariance matrix.

### 7.5.1 Markowitz

The Markowitz portfolio optimization problem in the worst case scenario is

$$\text{Max}_\theta \left\{ \min_{\mu,\Sigma} [\mu^T\theta - \frac{1}{2}\gamma\theta^T\Sigma\theta] \mid \bar{1}^T\theta = C_0 \right\}$$

where  $\gamma$  is the parameter of risk aversion. Because  $\gamma > 0$  we can write the problem as

$$Max_{\theta} \{ \min_{\mu} [\mu^T \theta] - \frac{1}{2} \gamma max_{\Sigma} [\theta^T \Sigma \theta] \mid \bar{1}^T \theta = C_0 \} \quad (7.5)$$

First, we find an expression for the minimum expected return:

$$\begin{aligned} \min_{\mu} [\mu^T \theta] &= \min_{\mu} \sum_i \mu_i \theta_i = \sum_{i: \theta_i < 0} (\mu_i^0 + \beta_i) \theta_i + \sum_{i: \theta_i \geq 0} (\mu_i^0 - \beta_i) \theta_i \\ &= \sum_i \mu_i^0 \theta_i + \sum_{i: \theta_i < 0} \beta_i \theta_i - \sum_{i: \theta_i \geq 0} \beta_i \theta_i = \sum_i (\mu_i^0 \theta_i - \beta_i |\theta_i|) \\ &= (\mu^0)^T \theta - \beta^T |\theta| \end{aligned} \quad (7.6)$$

We can do the same with the maximum variance. This gives

$$\begin{aligned} max_{\Sigma} [\theta^T \Sigma \theta] &= max_{\Sigma} \sum_{i,j} \sigma_{ij} \theta_i \theta_j \\ &= \sum_{i,j: \theta_i \theta_j < 0} (\sigma_{ij}^0 - \delta_{ij}) \theta_i \theta_j + \sum_{i,j: \theta_i \theta_j \geq 0} (\sigma_{ij}^0 + \delta_{ij}) \theta_i \theta_j \\ &= \sum_{i,j} \sigma_{ij}^0 \theta_i \theta_j + \sum_{i,j} \delta_{ij} |\theta_i \theta_j| = \sum_{i,j} \sigma_{ij}^0 \theta_i \theta_j + \sum_{i,j} \delta_{ij} |\theta_i| |\theta_j| \\ &= \theta^T \Sigma^0 \theta + |\theta|^T \Delta |\theta| \end{aligned} \quad (7.7)$$

With this results the optimization problem (7.5) becomes a bit simpler:

$$Max_{\theta} \{ (\mu^0)^T \theta - \beta^T |\theta| - \frac{1}{2} \gamma \theta^T \Sigma^0 \theta - \frac{1}{2} \gamma |\theta|^T \Delta |\theta| \mid \bar{1}^T \theta = C_0 \}$$

This problem is a SOCP, so it can be solved in an efficient way. To show this, we have to do some work. We add two variables  $\rho$  and  $\tau$  in the objective function. We get

$$Max_{\theta, \rho, \tau} \left\{ (\mu^0)^T \theta - \beta^T |\theta| - \frac{1}{2} \gamma \rho - \frac{1}{2} \gamma \tau \mid \begin{array}{l} \bar{1}^T \theta = C_0 \\ \rho \geq \theta^T \Sigma^0 \theta \\ \tau \geq |\theta|^T \Delta |\theta| \end{array} \right\}$$

Note that for any positive definite  $A$ , vector  $x$  and positive scalar  $y$  we can write

$$\begin{aligned} x^T A x \leq y &\Leftrightarrow 4x^T A x \leq 4y \Leftrightarrow 4x^T A x - 2y + y^2 + 1 \leq 2y + y^2 + 1 \\ &\Leftrightarrow 4x^T A^{1/2} A^{1/2} x + (1 - y)^2 \leq (1 + y)^2 \Leftrightarrow \left\| \begin{pmatrix} 2A^{1/2} x \\ 1 - y \end{pmatrix} \right\| \leq (1 + y) \end{aligned}$$

Using this, we can rewrite two constraints and get the following

$$Max_{\theta, \rho, \tau} \left\{ (\mu^0)^T \theta - \beta^T |\theta| - \frac{1}{2} \gamma (\rho + \tau) \mid \begin{array}{l} \bar{1}^T \theta = C_0 \\ \left\| \begin{pmatrix} 2(\Sigma^0)^{1/2} \theta \\ 1 - \rho \end{pmatrix} \right\| \leq 1 + \rho \\ \left\| \begin{pmatrix} 2\Delta^{1/2} |\theta| \\ 1 - \tau \end{pmatrix} \right\| \leq 1 + \tau \end{array} \right\}$$

which is almost a SOCP as in (7.3). The only problem is the absolute value sign of  $\theta$ . We can replace  $|\theta|$  by a new  $n$ -dimensional vector  $\eta$  and adding the constraints  $\eta_i \geq \theta_i$  and  $\eta_i \geq -\theta_i$  for all  $i$ , which guarantees  $\eta_i \geq |\theta_i|$ . Another way of dealing with the absolute value is replacing  $\theta$  respectively  $|\theta|$  by  $\theta = \theta^+ - \theta^-$  respectively  $|\theta| = \theta^+ + \theta^-$  and adding the positivity constraints  $\theta_i^+, \theta_i^- \geq 0$  for all  $i$ . We use the first transformation, which results in the following SOCP:

$$\text{Min}_{\theta, \rho, \tau, \eta} \left\{ \begin{array}{l} -(\mu^0)^T \theta + \beta^T \eta + \frac{1}{2} \gamma (\rho + \tau) \\ \bar{1}^T \theta = C_0 \\ \left\| \begin{pmatrix} 2(\Sigma^0)^{1/2} \theta \\ 1 - \rho \end{pmatrix} \right\| \leq 1 + \rho \\ \left\| \begin{pmatrix} 2\Delta^{1/2} \eta \\ 1 - \tau \end{pmatrix} \right\| \leq 1 + \tau \\ \eta_i \geq \theta_i \quad \text{for all } i \\ \eta_i \geq -\theta_i \quad \text{for all } i \end{array} \right. \right\}$$

This is the formulation of the Markowitz optimization problem as a SOCP. As stated before, this can be solved using a computer. The MATLAB program I use, `robustmarkowitz.m`, is in appendix C.

### 7.5.2 Telser

In the worst case scenario, the Telser optimization problem with VaR constraint becomes

$$\text{Max}_{\theta} \left\{ \min_{\mu} [\mu^T \theta] \mid \bar{1}^T \theta = C_0, \max_{\mu, \Sigma} [P(R_p \leq -VaR_c)] \leq \alpha \right\}$$

Since for the robust mean we have

$$\min_{\mu} [\mu^T \theta] = (\mu^0)^T \theta - \beta^T |\theta|$$

and for the VaR constraint

$$\begin{aligned} \max_{\mu, \Sigma} [P(R_p \leq -VaR_c)] \leq \alpha &\iff \max_{\mu, \Sigma} \frac{-VaR_c - \mu^T \theta}{\sqrt{\theta^T \Sigma \theta}} \leq z_{\alpha} \\ \iff \frac{-VaR_c - \min_{\mu} \mu^T \theta}{\max_{\Sigma} \sqrt{\theta^T \Sigma \theta}} \leq z_{\alpha} &\iff -\min_{\mu} \mu^T \theta - z_{\alpha} \max_{\Sigma} \sqrt{\theta^T \Sigma \theta} \leq VaR_c \end{aligned}$$

which can be transformed into

$$\begin{aligned} -(\mu^0)^T \theta + \beta^T |\theta| - z_{\alpha} \sqrt{\theta^T \Sigma^0 \theta + |\theta|^T \Delta |\theta|} &\leq VaR_c \\ \iff -z_{\alpha} \left\| \begin{pmatrix} \|(\Sigma^0)^{1/2} \theta\| \\ \|\Delta^{1/2} |\theta|\| \end{pmatrix} \right\| &\leq (\mu^0)^T \theta - \beta^T |\theta| + VaR_c \end{aligned}$$

So we have the following optimization problem:

$$\text{Max}_{\theta} \left\{ \begin{array}{l} (\mu^0)^T \theta - \beta^T |\theta| \\ \bar{1}^T \theta = C_0 \\ -z_{\alpha} \left\| \begin{pmatrix} \|(\Sigma^0)^{1/2} \theta\| \\ \|\Delta^{1/2} |\theta|\| \end{pmatrix} \right\| \leq (\mu^0)^T \theta - \beta^T |\theta| + VaR_c \end{array} \right. \right\}$$

To make it a SOCP we introduce new variables  $\rho$  and  $\tau$ , so the problem becomes

$$Max_{\theta, \rho, \tau} \left\{ \begin{array}{l} (\mu^0)^T \theta - \beta^T |\theta| \\ -z_\alpha \left\| \begin{pmatrix} \rho \\ \tau \end{pmatrix} \right\| \leq (\mu^0)^T \theta - \beta^T |\theta| + VaR_c \\ \bar{1}^T \theta = C_0 \\ \|(\Sigma^0)^{1/2} \theta\| \leq \rho \\ \|\Delta^{1/2} |\theta|\| \leq \tau \end{array} \right.$$

The last step is the introduction of the new variable  $\eta$  to remove the absolute value parameters. This gives us the SOCP

$$Min_{\theta, \rho, \tau, \eta} \left\{ \begin{array}{l} -(\mu^0)^T \theta + \beta^T \eta \\ -z_\alpha \left\| \begin{pmatrix} \rho \\ \tau \end{pmatrix} \right\| \leq (\mu^0)^T \theta - \beta^T \eta + VaR_c \\ \bar{1}^T \theta = C_0 \\ \|(\Sigma^0)^{1/2} \theta\| \leq \rho \\ \|\Delta^{1/2} \eta\| \leq \tau \\ \eta_i \geq \theta_i \quad \text{for all } i \\ \eta_i \geq -\theta_i \quad \text{for all } i \end{array} \right.$$

This SOCP can be solved using the MATLAB program `robusttelsr.m` in appendix C.

## 7.6 A more realistic approach

As we will see in the example, the approach described above is a very conservative approach. Main reason for this is the definition of worst case portfolio variance  $((\sigma_p^2)^{wc})$  we used. When deriving this worst case portfolio variance (7.7), we took for every element  $\sigma_{ij}$  of the covariance matrix the worst case element. In formulas:

$$(\sigma_p^2)^{wc} = (\theta^T \Sigma \theta)^{wc} = \sum_{i,j} \sigma_{ij}^{wc} \theta_i \theta_j$$

This means the worst case covariance matrix  $\Sigma^{wc}$  can be represented as

$$\Sigma^{wc} = \begin{pmatrix} \sigma_{11}^{wc} & \sigma_{12}^{wc} & \cdots & \sigma_{1n}^{wc} \\ \sigma_{21}^{wc} & \ddots & & \vdots \\ \vdots & & & \\ \sigma_{n1}^{wc} & \cdots & & \sigma_{nn}^{wc} \end{pmatrix}$$

But is it likely that this special case will occur? No is the answer. This is because this particular worst case covariance matrix is composed of covariances which do not belong to each other. The covariances are taken out of different covariance matrices, and so the correlation between the covariances is disturbed.

That is why it is more logic to compose the worst case portfolio variance as follows:

$$(\sigma_p^2)^{wc} = (\theta^T \Sigma \theta)^{wc} = \left( \sum_{i,j} \sigma_{ij} \theta_i \theta_j \right)^{wc}$$

So the worst case covariance matrix is given by

$$\Sigma^{wc} = \begin{pmatrix} \sigma_{11} & \sigma_{12} & \cdots & \sigma_{1n} \\ \sigma_{21} & \ddots & & \vdots \\ \vdots & & & \\ \sigma_{n1} & \cdots & & \sigma_{nn} \end{pmatrix}^{wc}$$

Suppose an investor knows (for example from studying the past) that there are  $m$  possible covariance matrices  $\Sigma^1, \Sigma^2, \dots, \Sigma^m$ . Then the worst case covariance matrix in the first meaning is the matrix that consists of all the worst case elements  $\sigma_{ij}^k$  for all  $i, j = 1, \dots, n$  and  $k = 1, \dots, m$ . The worst case covariance matrix in the second meaning is the worst case matrix  $\Sigma^k$  for all  $k = 1, \dots, m$ .

In this new situation we do not model parameter uncertainty in  $\mu$ . This is because according to the experts within Rabobank the uncertainty in the covariances is much more important than the uncertainty in the means. Furthermore the uncertainty in  $\mu$  is very difficult to measure.

### 7.6.1 Markowitz

This new way of modelling uncertainty can be applied to the optimal Markowitz portfolio. Assume there are  $m$  possible covariance matrices  $\Sigma^1, \Sigma^2, \dots, \Sigma^m$  and that the mean vector is 'certain'. Then the robust Markowitz problem

$$\text{Max}_{\theta} \left\{ \min_{\mu, \Sigma} [\mu^T \theta - \frac{1}{2} \gamma \theta^T \Sigma \theta] \mid \bar{1}^T \theta = C_0 \right\}$$

can be transformed to

$$\begin{aligned} & \text{Max}_{\theta} \left\{ \mu^T \theta - \frac{1}{2} \gamma \max_k [\theta^T \Sigma^k \theta] \mid \bar{1}^T \theta = C_0 \right\} \\ \Leftrightarrow & \text{Max}_{\theta} \left\{ \mu^T \theta - \frac{1}{2} \gamma \rho \mid \bar{1}^T \theta = C_0 \right. \\ & \left. \rho \geq \max_k [\theta^T \Sigma^k \theta] \right\} \\ \Leftrightarrow & \text{Max}_{\theta} \left\{ \mu^T \theta - \frac{1}{2} \gamma \rho \mid \bar{1}^T \theta = C_0 \right. \\ & \left. \rho \geq \theta^T \Sigma^k \theta \text{ for all } k \right\} \\ \Leftrightarrow & \text{Min}_{\theta} \left\{ -\mu^T \theta + \frac{1}{2} \gamma \rho \mid \bar{1}^T \theta = C_0 \right. \\ & \left. \left\| \begin{pmatrix} 2(\Sigma^k)^{1/2} \theta \\ 1 - \rho \end{pmatrix} \right\| \leq 1 + \rho \text{ for all } k \right\} \end{aligned}$$

This is a SOCP. Note that this expression is simpler than the previously created version of the uncertain Markowitz problem. The corresponding MATLAB program `robustmarkowitz2.m` is in appendix C.

### 7.6.2 Telser

For the Telser problem with VaR constraint we can do the same. The robust VaR constraint is

$$\begin{aligned} \text{max}_{\Sigma} [P(R_p \leq -VaR_c)] \leq \alpha & \Leftrightarrow \text{max}_k \frac{-VaR_c - \mu^T \theta}{\sqrt{\theta^T \Sigma^k \theta}} \leq z_{\alpha} \\ \Leftrightarrow \frac{-VaR_c - \mu^T \theta}{\text{max}_k \sqrt{\theta^T \Sigma^k \theta}} \leq z_{\alpha} & \Leftrightarrow -z_{\alpha} \text{max}_k \sqrt{\theta^T \Sigma^k \theta} \leq \mu^T \theta + VaR_c \end{aligned}$$

$$\begin{aligned} \Leftrightarrow \quad & -z_\alpha \sqrt{\theta^T \Sigma^k \theta} \leq \mu^T \theta + VaR_c \quad \text{for all } k \\ \Leftrightarrow \quad & -z_\alpha \|(\Sigma^k)^{1/2} \theta\| \leq \mu^T \theta + VaR_c \quad \text{for all } k \end{aligned}$$

So the robust Telser optimization problem becomes

$$Min_\theta \left\{ \begin{array}{l} -\mu^T \theta \\ -z_\alpha \|(\Sigma^k)^{1/2} \theta\| \leq \mu^T \theta + VaR_c \quad \text{for all } k \end{array} \middle| \bar{1}^T \theta = C_0 \right\}$$

This is the another version of the uncertain Telser optimization problem. The MATLAB program for solving this has the name `robusttelser2.m` and can be found in appendix C.

## 7.7 Example

The programs of this chapter will be implemented in our example. First we will find the uncertainty sets of  $\mu$  and  $\Sigma$ . When this is done, we run the MATLAB programs of appendix C to see what the results are.

### 7.7.1 Uncertainty sets

An important question is how to determine the uncertainty sets. Tütüncü and Koenig [2002] propose two methods. The first method is a bootstrapping method, where time series are bootstrapped from the available data. The second method is a moving window method. A window of 60 days is taken and within this window the means and covariances are determined. The window is moved back in time to get lower and upper bounds for the means and covariances.

I will use a variant of the last method. Also a window of 60 days is taken, and means and covariances are calculated for this window. Then the window is moved 60 days back in time to calculate the second mean vector and covariance matrix. This is done 60 times (because we have 3609 observations), so at the end we have 60 possible mean vectors and 60 possible covariance matrices. Notice that the first 9 observations (this are observations in the year 1990!) are ignored. From these data the uncertainty sets are determined.

The data give the following lower and upper bounds for means and covariances (see the tables).

$\times 10^{-3}$	$\mu_i^L$	$\mu_i^U$
Elsevier	-4.79	4.86
Fortis	-6.37	8.35
Getronics	-32.79	29.21
Heineken	-3.28	6.26
Philips	-12.00	7.59
Royal Dutch	-3.19	4.71
Unilever	-4.88	4.71

Table 7.1: Lower and upper bounds for means

With this lower and upper bounds it is easy to determine the vectors  $\mu^0$  and  $\beta$ , and the matrices  $\Sigma^0$  and  $\Delta$ . With the means for example, we use

$$\mu_i^0 = \frac{\mu_i^L + \mu_i^U}{2} \quad \forall i \quad \text{and} \quad \beta_i = \frac{\mu_i^U - \mu_i^L}{2} \quad \forall i$$

$\times 10^{-3}$	Els	For	Get	Hei	Phi	RDu	Uni
Elsevier	0.057	-0.009	-0.017	-0.049	-0.045	-0.065	-0.035
	1.721	1.300	2.109	0.448	1.060	0.549	0.528
Fortis	-0.009	0.065	-0.171	-0.029	-0.219	-0.006	0.000
	1.300	2.508	2.185	0.532	1.830	1.340	0.994
Getronics	-0.017	-0.171	0.059	-0.175	-0.048	-0.222	-0.430
	2.109	2.185	29.715	0.707	1.977	0.990	1.127
Heineken	-0.049	-0.029	-0.175	0.039	-0.166	-0.030	-0.005
	0.448	0.532	0.707	1.024	0.525	0.420	0.352
Philips	-0.045	-0.219	-0.048	-0.166	0.081	-0.065	-0.556
	1.060	1.830	1.977	0.525	3.049	1.242	0.838
Royal Dutch	-0.065	-0.006	-0.222	-0.030	-0.065	0.029	-0.022
	0.549	1.340	0.990	0.420	1.242	1.156	0.758
Unilever	-0.035	0.000	-0.430	-0.005	-0.556	-0.022	0.031
	0.528	0.994	1.127	0.352	0.838	0.758	0.986

Table 7.2: Lower and upper bounds for covariances

to determine the wanted vectors. This gives the following vectors:

$$\mu^0 = \begin{pmatrix} 0.036 \\ 0.988 \\ -1.793 \\ 1.493 \\ -2.204 \\ 0.760 \\ -0.088 \end{pmatrix} \times 10^{-3} \quad \beta = \begin{pmatrix} 4.826 \\ 7.358 \\ 31.002 \\ 4.771 \\ 9.791 \\ 3.952 \\ 4.796 \end{pmatrix} \times 10^{-3}$$

For covariances the same properties hold. So the matrices  $\Sigma^0$  and  $\Delta$  are:

$$\Sigma^0 = \begin{pmatrix} 0.889 & 0.645 & 1.046 & 0.200 & 0.508 & 0.242 & 0.247 \\ 0.645 & 1.287 & 1.007 & 0.252 & 0.806 & 0.667 & 0.497 \\ 1.046 & 1.007 & 14.887 & 0.266 & 0.965 & 0.384 & 0.348 \\ 0.200 & 0.252 & 0.266 & 0.532 & 0.180 & 0.195 & 0.173 \\ 0.508 & 0.806 & 0.965 & 0.180 & 1.565 & 0.589 & 0.141 \\ 0.242 & 0.667 & 0.384 & 0.195 & 0.589 & 0.592 & 0.368 \\ 0.247 & 0.497 & 0.348 & 0.173 & 0.141 & 0.368 & 0.509 \end{pmatrix} \times 10^{-3}$$

$$\Delta = \begin{pmatrix} 0.832 & 0.654 & 1.063 & 0.249 & 0.553 & 0.307 & 0.282 \\ 0.654 & 1.221 & 1.178 & 0.281 & 1.024 & 0.673 & 0.497 \\ 1.063 & 1.178 & 14.828 & 0.441 & 1.012 & 0.606 & 0.778 \\ 0.249 & 0.281 & 0.441 & 0.493 & 0.346 & 0.225 & 0.178 \\ 0.553 & 1.024 & 1.012 & 0.346 & 1.484 & 0.653 & 0.697 \\ 0.307 & 0.673 & 0.606 & 0.225 & 0.653 & 0.564 & 0.390 \\ 0.282 & 0.497 & 0.778 & 0.178 & 0.697 & 0.390 & 0.478 \end{pmatrix} \times 10^{-3}$$

For our second way of dealing with uncertainty, described in section 7.6, we have to use the 60 covariance matrices that are already determined.



## 7.7.2 Calculations

We calculate the optimal Markowitz portfolio, with consideration of parameter uncertainty, using `robustmarkowitz.m`. We take for the parameter of risk aversion  $\gamma = 2$ . This gives the optimal portfolio

$$\theta_{opt} = \begin{pmatrix} 0 \\ 0 \\ 0 \\ 0.5168 \\ 0 \\ 0.4832 \\ 0 \end{pmatrix}$$

with expected portfolio return  $\mu_p = 0.380 \times 10^{-3}$  and standard deviation  $\sigma_p = 0.0122$ . If the investor is more risk averse (we take  $\gamma = 10$ ), the optimum is

$$\theta_{opt} = \begin{pmatrix} 0.059 \\ 0 \\ 0 \\ 0.498 \\ 0 \\ 0.375 \\ 0.067 \end{pmatrix}, \quad \mu_p = 0.379 \times 10^{-3}, \quad \sigma_p = 0.0117$$

It is possible to check the computer algorithm by using  $\beta = \bar{0}_{7 \times 1}$  and  $\Delta = \bar{0}_{7 \times 7}$ , and running the program with parameters  $\mu$  and  $\Sigma$ . This should give the normal optimal Markowitz portfolio of chapter 2, without parameter uncertainty. Checking this learns that this gives the correct answer.

The optimal Telser portfolio with VaR constraint with parameter uncertainty is calculated with `robusttelser.m`. We take  $VaR_c = 0.05$  and assume a student-t distribution, so  $z_\alpha = -1.998$  for  $\alpha = 0.025$ , and calculate the optimal Telser portfolio. This gives

$$\theta_{opt} = \begin{pmatrix} 0.119 \\ -0.001 \\ -0.001 \\ 0.415 \\ -0.001 \\ 0.157 \\ 0.311 \end{pmatrix}, \quad \mu_p = 0.368 \times 10^{-3}, \quad \sigma_p = 0.0115$$

If we apply the less rigorous way of dealing with uncertainty, as described in section 7.6, we use the program `robustmarkowitz2.m` for the optimal Markowitz portfolio with parameter uncertainty. For  $\gamma = 2$ , this results in

$$\theta_{opt} = \begin{pmatrix} 0.353 \\ -0.054 \\ 0.019 \\ 0.367 \\ -0.077 \\ 0.111 \\ 0.283 \end{pmatrix}, \quad \mu_p = 0.346 \times 10^{-3}, \quad \sigma_p = 0.0121$$

If  $\gamma = 10$ , the results are

$$\theta_{opt} = \begin{pmatrix} 0.349 \\ -0.049 \\ 0.017 \\ 0.247 \\ -0.123 \\ 0.232 \\ 0.327 \end{pmatrix}, \quad \mu_p = 0.306 \times 10^{-3}, \quad \sigma_p = 0.0120$$

For the Telser robust optimal portfolio (use `robusttelser2.m`), the results are

$$\theta_{opt} = \begin{pmatrix} 0.319 \\ -0.077 \\ -0.064 \\ 0.634 \\ 0.019 \\ -0.096 \\ 0.266 \end{pmatrix}, \quad \mu_p = 0.441 \times 10^{-3}, \quad \sigma_p = 0.0139, \quad VaR_\alpha = 0.0272$$

The optimal points can be plotted in the next figure. The figure is in mean-standard deviation framework. The crossed points belong to the first way of dealing with uncertainty, the boxed points belong to the second.

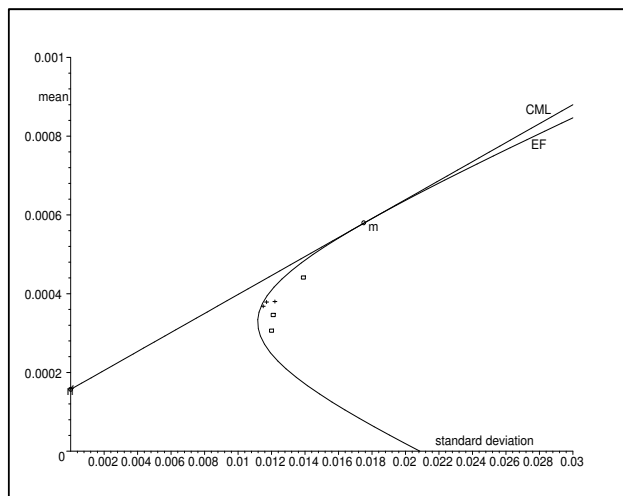

Figure 7.2: The optimal portfolios with uncertainty

Notice that the optimal points are not on the efficient frontier. Because we are dealing with parameter uncertainty the investor is investing more safe. In fact, the efficient frontier changes, because the efficient frontier is not efficient anymore. New efficient points can be calculated by repeatedly calculate the efficient standard deviation for a given mean. Running this simulation gives the following new frontier, where the second way of dealing with uncertainty is used. The frontier that is closest to the old efficient frontier, is the expected new frontier. This frontier arises when the uncertain covariance matrix appears

to be the expected covariance matrix, based on all the data of the past thirteen years. This frontier is different from the old one (although the covariance matrix is the expected one), because the parameter uncertainty is taken into account, and thus it is more safe. The boxed portfolios are on this frontier, as can be seen in the figure. The new frontier on the inside of the other frontiers is the efficient frontier that arises when the worst case covariance matrix appears. It is clear that, when this worst case scenario occurs, the investor must be very reserved.

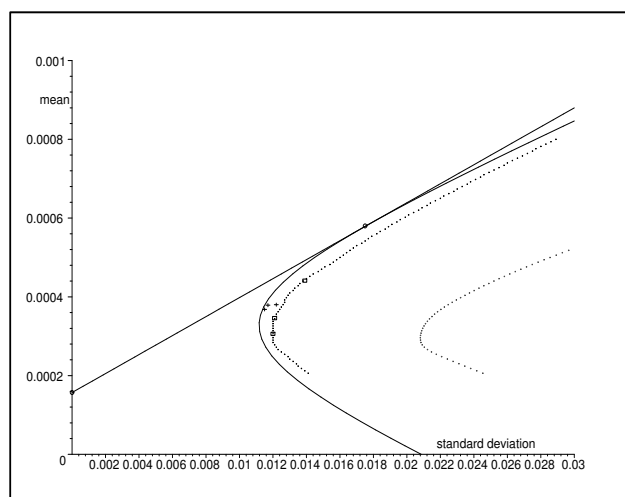

Figure 7.3: The new efficient frontiers

## 7.8 References

- Alizadeh, Goldfarb [2002] *Second-order Cone Programming*
- Anderson, Roos, Terlaky [2000] *Notes on Duality in Second Order and  $p$ -order Cone Optimization*
- Ben-Tal, Nemirovski, Roos [2001] *Robust Solutions of Uncertain Quadratic and Conic-quadratic Problems*
- Black, Litterman [1990] "Asset Allocation: Combining Investor Views with Market Equilibrium: Technical Report" *Fixed Income Research*
- Chopra [1993] *Improving Optimization*
- Frost, Savarino [1988] "For Better Performance: Constrain Portfolio Weights" *Journal of Portfolio Management*
- Fukushima, Yamashita [2001] *Multiperiod Portfolio Selection with Second-order Cone Constraints*
- Goldfarb [2002] *The Simplex Method for Conic Programming*

- Goldfarb, Iyengar [2003] "Robust Portfolio Selection Problems" *Mathematics of Operations Research* 1
- Goldfarb, Iyengar [2002] *Robust Convex Quadratically Constrained Programs*
- Halldórsson, Tütüntü [2002] *An Interior-point Method for a Class of Saddle-point Problems*
- Jorion [1986] "Bayes-Stein Estimation for Portfolio Analysis" *Journal of Financial and Quantitative Analysis* Vol.21, No.3
- Krishnan [2002] *Lecture Notes about Topics in Nonlinear Programming*
- Lobo [2000] *Robust and Convex Optimization with Applications in Finance*
- Lobo, Vandenberghe, Boyd, Lebret [1998] *Applications of Second-order Cone Programming*
- Michaud [1998] *Efficient Asset Management: A Practical Guide to Stock Portfolio Management and Asset Allocation*
- Löfberg [] *YALMIP 2.4* <http://www.control.isy.liu.se/johanl/yalmip.html>
- Sturm [] *SEDUMI 1.05* <http://fewcal.kub.nl/sturm/software/sedumi.html>
- Tütüntü, Koenig [2003] *Robust Asset Allocation*
- Vanderbei, Yurttan [1998] *Using LOQO to Solve Second-order Cone Programming Problems*
- Yildirim [2001] *On Sensitivity Analysis in Conic Programming*
- Ziemba, Mulvey [1998] *Worldwide Asset and Liability Modelling*



---

# Conclusion

---

This thesis presents the results of a study to different portfolio optimization models in a mathematical way. It starts with the theory of Markowitz, which is extended throughout the thesis to some different Telser models based on a Value at Risk constraint. Each Telser model works not only with normally distributed returns, but also with each distribution from the elliptical family. If an investor prefers to maximize his EVA or RAROC, this is no problem and the existing framework can be used. Finally, a proposal is done for modelling uncertainty in the input parameters, which can be solved using second order cone programming.

The next concluding example shows that the learnt theory can be helpful in practice.

## 8.1 Concluding example

We have used an example with seven members of the Dutch AEX index, and have shown how the different optimal portfolio allocations are when different optimization methods are used. We conclude this example by answering the question if we can outperform the AEX index with our seven securities, without taking more risk than the AEX takes.

We took AEX data of log-returns from the same period as we did for the securities, from the 1st of January 1990 up to and including the 31st of October 2003, in total 3609 observations. From these data, the following parameters are defined:

$$\mu_{aex} = 0.245 \times 10^{-3}$$

$$\sigma_{aex} = 0.0134$$

$$VaR_{aex} = 0.0286 \quad (\text{with } \alpha = 0.025)$$

The Value at Risk is determined by sorting all 3609 returns from low to high, and taking the  $0.025 \cdot 3609 = 90th$  observation for the VaR with confidence level 97,5%.

Suppose we have 100 euro to invest. If we would have invested this in the AEX (so  $\theta_{aex} = 100$ ), we would have had an expected portfolio return of

$$\mu_p = \mu_{aex} \theta_{aex} = 0.245 \times 10^{-3} \cdot 100 = 0.0245.$$

The standard deviation would be

$$\sigma_p = \sqrt{\theta_{aex} \sigma_{aex}^2 \theta_{aex}} = \sqrt{100 \cdot 0.0134^2 \cdot 100} = 1.34$$

The VaR for the portfolio is still the 90th observation, so it is

$$VaR_\alpha = 2.86$$

Let's see if we can improve the expected return without taking more risk, by using our seven securities. We first take the Markowitz point of view, so the standard deviation is the risk measure. We maximize the expected portfolio return subject to a standard deviation constraint and the budget constraint.

$$Max \left\{ \mu^T \theta \mid \begin{array}{l} \sqrt{\theta^T \Sigma \theta} = 1.34 \\ \mathbf{1}^T \theta = 100 \end{array} \right\}$$

This gives as solution

$$\theta_{opt} = \begin{pmatrix} 3.12 \\ -7.02 \\ -2.38 \\ 74.30 \\ 9.39 \\ 9.80 \\ 12.79 \end{pmatrix}, \quad \mu_{opt} = 0.0466, \quad \sigma_{opt} = 1.34$$

We see we can almost get a two times higher expected return by using the above investment of the 100 euro. The standard deviation (risk) stays the same.

If we optimize subject to the VaR constraint, we have to solve

$$Max \left\{ \mu^T \theta \mid \begin{array}{l} VaR_c = 2.86 \\ \mathbf{1}^T \theta = 100 \end{array} \right\}$$

which has optimal solution

$$\theta_{opt} = \begin{pmatrix} 0.45 \\ -8.81 \\ -3.39 \\ 86.40 \\ 12.19 \\ 3.96 \\ 9.19 \end{pmatrix}, \quad \mu_{opt} = 0.0502, \quad \sigma_{opt} = 1.46, \quad VaR_\alpha = 2.86$$

So using this VaR constraint, we can get an even higher expected return while the risk stays the same. Note that the two optimal portfolios do not differ much. They both rely very strong on the good performance of Heineken.

Will this work in practice? A well known warning is that results achieved in the past do not give any guarantees for the future. Since all our data are obtained from the past, we can not say anything about what will happen in reality. The future will teach us.

## 8.2 Future research

This thesis gives a broad overview of possible optimization models. Although, I only studied the one-period case. It is interesting to study the multi-period case and see what happens with the optimal solutions if a longer horizon is chosen. It appears to me that if an optimal solution is linearly dependent on the invested capital  $C_0$ , the optimal invested fractions do not change so the optimal multi-period solution is the myopic one-period one. This is the case for most of the discussed portfolios. However, both the optimal Markowitz portfolio and the optimal Telser portfolio with Value at Risk constraint do not satisfy this property, and the multi-period optimal portfolio does not have to be the myopic optimum.

I have modelled parameter uncertainty in a way that arose during some knowledge meetings during my internship. It seemed the most efficient and performable way of modelling the uncertainty in input parameters. I can imagine that the results can be improved by looking at this subject in a more statistical way, for example with Bayes-Stein estimators.

My last recommendation for future research is to examine whether or not an implementation in an Excel environment is possible for solving SOCP's. I tried to find a suitable Excel program, but have not succeeded. MATLAB stayed the most effective by far. For a mathematician this is no problem, but if a computer program has to be written for a trader who invests in securities and has to know in a few seconds what happens with his portfolio risk if he makes a buy, the MATLAB environment is not user-friendly enough.





---

## Some large calculations

---

This appendix contains some computations of large calculations in this thesis.

### A.1 The market portfolio

The market portfolio is calculated by solving the following equation:

$$\sigma_p = \sqrt{\frac{1}{d}(c\mu_p^2 - 2b\mu_p C_0 + aC_0^2)} = \frac{\mu_p - \mu_f C_0}{s}$$

with  $s = \sqrt{c\mu_f^2 - 2b\mu_f + a}$ . Taking squares on both sides gives

$$\frac{1}{d}(c\mu_p^2 - 2b\mu_p C_0 + aC_0^2) = \frac{\mu_p^2 - 2\mu_p C_0 \mu_f + C_0^2 \mu_f^2}{s^2}.$$

Bringing each term to the left side results in

$$\frac{cs^2 - d}{d}\mu_p^2 + \frac{-2bs^2 + 2d\mu_f}{d}C_0\mu_p + \frac{as^2 - d\mu_f^2}{d}C_0^2 = 0.$$

This is a quadratic equation, so the solution can be determined using the abc-formula. Because  $d > 0$ , we first multiply the equation with  $d$  to make it easier. The discriminant  $D$  is

$$\begin{aligned} D &= (cs^2 - d)(as^2 - d\mu_f^2)C_0^2 - (-2bs^2 + 2d\mu_f)^2 C_0^2 \\ &= C_0^2 (4b^2 s^4 + 4\mu_f^2 d^2 - 8bs^2 \mu_f d - 4acs^4 + 4c ds^2 \mu_f^2 + 4ads^2 - 4d^2 \mu_f^2) \\ &= 4s^2 C_0^2 (- (ac - b^2)s^2 - 2bd\mu_f + cd\mu_f^2 + ad). \end{aligned}$$

Remember that  $d = ac - b^2$ , so

$$\begin{aligned} D &= 4s^2 C_0^2 (-ds^2 - 2bd\mu_f + cd\mu_f^2 + ad) \\ &= 4ds^2 C_0^2 (-s^2 + c\mu_f^2 - 2b\mu_f + a) \\ &= 4ds^2 C_0^2 (-s^2 + s^2) = 0. \end{aligned}$$

So the discriminant is zero and there is one solution. This means that the solution indeed is a point of tangency, and that the CML is a tangency line. We continue the calculation of  $\mu_p$  with the abc-formula:

$$\begin{aligned} \mu_p &= \frac{2bs^2 - 2\mu_f d}{2(cs^2 - d)} C_0 \\ &= \frac{bs^2 - d\mu_f}{cs^2 - d} C_0 \\ &= \frac{b(c\mu_f^2 - 2b\mu_f + a) - (ac - b^2)\mu_f}{c(c\mu_f^2 - 2b\mu_f + a) - (ac - b^2)} C_0 \\ &= \frac{bc\mu_f^2 - b^2\mu_f + ab - ac\mu_f}{c^2\mu_f^2 - 2bc\mu_f + b^2} C_0 \\ &= \frac{(c\mu_f - b)(b\mu_f - a)}{(c\mu_f - b)^2} \\ &= \frac{a - b\mu_f}{b - c\mu_f} \end{aligned}$$

The corresponding value for the standard deviation can be found by using this value for the mean in the efficient frontier formula. This gives

$$\begin{aligned} \sigma_p &= \sqrt{\frac{1}{d} [c\mu_p^2 - 2bC_0\mu_p + aC_0^2]} \\ &= \sqrt{\frac{1}{d} \left[ c \left( \frac{a - b\mu_f}{b - c\mu_f} C_0 \right)^2 - 2bC_0 \left( \frac{a - b\mu_f}{b - c\mu_f} C_0 \right) + aC_0^2 \right]} \\ &= \frac{\sqrt{c\mu_f^2 - 2b\mu_f + a}}{b - c\mu_f} C_0 \\ &= \frac{s}{b - c\mu_f} C_0 \end{aligned}$$

This result can also be achieved by using the CML formula:

$$\begin{aligned} \sigma_p &= \frac{\mu_p - \mu_f C_0}{s} \\ &= \frac{(a - b\mu_f) - (b - c\mu_f)\mu_f}{s(b - c\mu_f)} C_0 \\ &= \frac{s}{b - c\mu_f} C_0 \end{aligned}$$

So the market portfolio is given by

$$\mu_m = \frac{a - b\mu_f}{b - c\mu_f} C_0, \quad \sigma_m = \frac{s}{b - c\mu_f} C_0$$

## A.2 The Telser portfolio

The equation that has to be solved to calculate the optimal Telser portfolio is

$$\frac{1}{d} (c\mu_p^2 - 2bC_0\mu_p + aC_0^2) = \left( \frac{-C_0 - \mu_p}{k_\alpha} \right)^2.$$

Because  $d > 0$ , this can be written as

$$k_\alpha^2 (c\mu_p^2 - 2bC_0\mu_p + aC_0^2) = d (C_0^2 + 2C_0\mu_p + \mu_p^2).$$

Bring all factors to the left side gives

$$(ck_\alpha^2 - d)\mu_p^2 - (2d + 2bk_\alpha^2)C_0\mu_p + (ak_\alpha^2 - d)C_0^2 = 0.$$

This quadratic equation is solved using the abc-formula. The discriminant  $D$  is

$$\begin{aligned} D &= (-(2d + 2bk_\alpha^2)C_0)^2 - 4(ck_\alpha^2 - d)(ak_\alpha^2 - d)C_0^2 \\ &= C_0^2 [4d^2 + 4b^2k_\alpha^4 + 8bdk_\alpha^2 - 4ack_\alpha^4 + 4cdk_\alpha^2 + 4adk_\alpha^2 - 4d^2] \\ &= 4k_\alpha^2 C_0^2 [-(ac - b^2)k_\alpha^2 + 2bd + cd + ad]. \end{aligned}$$

We use that  $d = ac - b^2$ , and get

$$D = 4C_0^2 [dk_\alpha^2(a + 2b + c - k_\alpha^2)].$$

Applying the abc-formula gives

$$\begin{aligned} \mu_p &= \frac{2d + 2bk_\alpha^2 + 2\sqrt{dk_\alpha^2(a + 2b + c - k_\alpha^2)}}{2(ck_\alpha^2 - d)} C_0 \\ &= \frac{d + bk_\alpha^2 + \sqrt{dk_\alpha^2(a + 2b + c - k_\alpha^2)}}{ck_\alpha^2 - d} C_0 \end{aligned}$$

which is the desired optimal value for  $\mu^T$ .

## A.3 The Value at Risk efficient frontier

This is a sub-calculation for the derivation of the VaR efficient frontier. We have the following three equations to solve the unknown  $\lambda_3$ :

$$\begin{cases} VaR_\alpha^2 + 2VaR_\alpha\mu^T\theta + \theta^T\Psi\theta = 0 \\ \theta = (\lambda_3 - VaR_\alpha)\Psi^{-1}\mu + \lambda_4\Psi^{-1}\bar{1} \\ \lambda_4 = \frac{C_0 - \hat{b}(\lambda_3 - VaR_\alpha)}{\hat{c}} \end{cases} \quad (\text{A.1})$$

We first calculate  $\theta^T\Psi\theta$ . This gives

$$\begin{aligned} \theta^T\Psi\theta &= \\ &= ((\lambda_3 - VaR_\alpha)\mu^T\Psi^{-1} + \lambda_4\bar{1}^T\Psi^{-1})\Psi\theta \\ &= (\lambda_3 - VaR_\alpha)\mu^T\theta + \lambda_4\bar{1}^T\theta. \end{aligned}$$

One of the constraints is the budget constraint, which states that  $\bar{1}^T \theta = C_0$ . Applying this, the result is

$$\theta^T \Psi \theta = (\lambda_3 - VaR_\alpha) \mu^T \theta + \lambda_4 C_0.$$

If we use this expression in the first equation of (A.1), we get

$$VaR_\alpha^2 + 2VaR_\alpha \mu^T \theta + (\lambda_3 - VaR_\alpha) \mu^T \theta + \lambda_4 C_0 = 0$$

which can be rewritten as

$$VaR_\alpha^2 + (\lambda_3 + VaR_\alpha) \mu^T \theta + \lambda_4 C_0 = 0. \quad (\text{A.2})$$

We derive an expression for  $\mu^T \theta$ . This is

$$\begin{aligned} \mu^T \theta &= \mu^T ((\lambda_3 - VaR_\alpha) \Psi^{-1} \mu + \lambda_4 \Psi^{-1} \bar{1}) \\ &= (\lambda_3 - VaR_\alpha) \hat{a} + \lambda_4 \hat{b}. \end{aligned}$$

We use the expression for  $\lambda_4$  to get

$$\begin{aligned} \mu^T \theta &= (\lambda_3 - VaR_\alpha) \frac{\hat{a}\hat{c}}{\hat{c}} + \frac{\hat{b}C_0 - \hat{b}^2(\lambda_3 - VaR_\alpha)}{\hat{c}} \\ &= \frac{\hat{d}(\lambda_3 - VaR_\alpha) + \hat{b}C_0}{\hat{c}}. \end{aligned}$$

Using this, and the expression for  $\lambda_4$ , in equation (A.2), the result is

$$\begin{aligned} VaR_\alpha^2 + \frac{\hat{d}(\lambda_3 + VaR_\alpha)(\lambda_3 - VaR_\alpha)}{\hat{c}} + \frac{\hat{b}C_0(\lambda_3 - VaR_\alpha)}{\hat{c}} \\ + \frac{C_0^2 - \hat{b}(\lambda_3 - VaR_\alpha)C_0}{\hat{c}} = 0 \\ \Leftrightarrow \frac{\hat{c}VaR_\alpha^2}{\hat{c}} + \frac{\hat{d}}{\hat{c}}(\lambda_3^2 - VaR_\alpha^2) + \frac{\hat{b}}{\hat{c}}\lambda_3 C_0 + \frac{\hat{b}}{\hat{c}}VaR_\alpha C_0 \\ + \frac{C_0^2}{\hat{c}} - \frac{\hat{b}}{\hat{c}}\lambda_3 C_0 + \frac{\hat{b}}{\hat{c}}VaR_\alpha C_0 = 0 \end{aligned}$$

and this can be written as

$$(\hat{c} - \hat{d})VaR_\alpha^2 + \hat{d}\lambda_3^2 + 2\hat{b}VaR_\alpha C_0 + C_0^2 = 0.$$

So the for  $\lambda_3$  we have

$$\lambda_3^2 = \frac{1}{\hat{d}} \left( (\hat{d} - \hat{c})VaR_\alpha^2 - 2\hat{b}VaR_\alpha C_0 + C_0^2 \right)$$

which is the desired expression.

---

## Telser portfolio analytical

---

### B.1 No risk-free asset

This appendix calculates the optimal Telser portfolio with no risk-free, in an rigorous analytical way. The results appear to be the same as the results derived in the regular Telser section.

To make things easier it is useful to define the following parameters:

$$\Psi \equiv (1 + \mu)(1 + \mu)^T - k_\alpha^2 \Sigma$$

and

$$\begin{aligned} a' &\equiv \mu^T \Psi^{-1} \mu \\ b' &\equiv \mu^T \Psi^{-1} \bar{1} = \bar{1}^T T^{-1} \mu \\ c' &\equiv \bar{1}^T \Psi^{-1} \bar{1} \\ d' &\equiv a' c' - b'^2 \end{aligned}$$

$\Psi$  is an  $(N \times N)$ -matrix. We assume it is invertible. Note that

$$\begin{aligned} \Psi^T &= [(\bar{1} + \mu)(\bar{1} + \mu)^T - k_\alpha^2 \Sigma]^T = [(\bar{1} + \mu)^T]^T (\bar{1} + \mu)^T - k_\alpha^2 \Sigma^T \\ &= (\bar{1} + \mu)(\bar{1} + \mu)^T - k_\alpha^2 \Sigma = \Psi \end{aligned}$$

so  $\Psi$  is symmetric.

There is a relationship between parameters  $a', b', c', d'$  and the previous defined  $a, b, c, d$ . This relationship can be seen as follows. Multiply  $\Psi$  on the left by  $\Sigma^{-1}$  and on the right by  $\Psi^{-1}$ . We get

$$\Sigma^{-1} \Psi \Psi^{-1} = \Sigma^{-1} (\bar{1} + \mu)(\bar{1} + \mu)^T \Psi^{-1} - k_\alpha^2 \Sigma^{-1} \Sigma \Psi^{-1}$$

So

$$\Sigma^{-1} = \Sigma^{-1} (\bar{1} + \mu)(\bar{1} + \mu)^T \Psi^{-1} - k_\alpha^2 \Psi^{-1}$$

$$= \Sigma^{-1}(\bar{1}\bar{1}^T + \bar{1}\mu^T + \mu\bar{1}^T + \mu\mu^T)\Psi^{-1} - k_\alpha^2\Psi^{-1}$$

With this expression for  $\Sigma^{-1}$  we see the following:

$$\begin{aligned} a &= \mu^T\Sigma^{-1}\mu = \mu^T\Sigma^{-1}(\bar{1}\bar{1}^T + \bar{1}\mu^T + \mu\bar{1}^T + \mu\mu^T)\Psi^{-1}\mu - k_\alpha^2\mu^T\Psi^{-1}\mu \\ &= bb' + ba' + ab' + aa' - k_\alpha^2a' = (a+b)(a'+b') - k_\alpha^2a' \end{aligned}$$

In a similar way we can get expressions for  $b$  and  $c$ :

$$b = \bar{1}^T\Sigma^{-1}\mu = cb' + ca' + bb' + ba' - k_\alpha^2b' = (b+c)(a'+b') - k_\alpha^2b'$$

or, if we use the other definition for  $b'$ :

$$b = \mu^T\Sigma^{-1}\bar{1} = bc' + ac' + bb' + ab' - k_\alpha^2b' = (a+b)(b'+c') - k_\alpha^2b'$$

$$c = cc' + bc' + cb' + bb - k_\alpha^2c' = (b+c)(b'+c') - k_\alpha^2c'$$

which gives the system (we used the first expression for  $b'$ ):

$$\begin{cases} a + k_\alpha^2a' &= (a+b)(a'+b') \\ b + k_\alpha^2b' &= (b+c)(a'+b') \\ c + k_\alpha^2c' &= (b+c)(b'+c') \end{cases} \quad (\text{B.1})$$

This system has three equations for the three unknowns  $a', b', c'$ , so it can be solved. After some straightforward calculations it follows that

$$\begin{aligned} a' &= \frac{ak_\alpha^2 - d}{k_\alpha^2(a + 2b + c - k_\alpha^2)} \\ b' &= \frac{bk_\alpha^2 + d}{k_\alpha^2(a + 2b + c - k_\alpha^2)} \\ c' &= \frac{ck_\alpha^2 - d}{k_\alpha^2(a + 2b + c - k_\alpha^2)} \end{aligned}$$

and by using that  $d' = a'c' - b'^2$  it can be shown that

$$d' = \frac{-d}{k_\alpha^2(a + 2b + c - k_\alpha^2)}$$

Later on it will be clear that, if an optimal solution of (3.2) exists, the factor  $d'$  must be negative. This means that the denominator of the above expressions  $k_\alpha^2(a + 2b + c - k_\alpha^2)$  must be positive (because  $-d < 0$ ). Written in another way this gives that an optimal solution exists if

$$|k_\alpha| < \sqrt{a + 2b + c}$$

Look again at system (3.2). By combining some constraints we can simplify the system. The first constraint gives

$$\mu_p + C_0 \geq -k_\alpha\sigma_p \Rightarrow \mu_p^2 + 2\mu_p C_0 + C_0^2 \geq k_\alpha^2\sigma_p^2$$

Making use of the last three constraints (expressions for  $\mu_p, \sigma_p, C_0$ ) we can transform the above constraint in

$$\theta^T\mu\mu^T\theta + 2\theta^T\mu\bar{1}^T\theta + \theta^T\bar{1}\bar{1}^T\theta \geq k_\alpha^2\theta^T\Sigma\theta$$

$$\begin{aligned}\theta^T [(\mu + \bar{1})(\mu + \bar{1})^T - k_\alpha^2 \Sigma] \theta &\geq 0 \\ \theta^T \Psi \theta &\geq 0\end{aligned}$$

So system (3.2) can be simplified to

$$\text{Max} \left\{ \mu^T \theta \mid \begin{array}{l} -\theta^T \Psi \theta \leq 0 \\ \bar{1}^T \theta - C_0 = 0 \end{array} \right\} \quad (\text{B.2})$$

This system can not be solved using Lagrange's method, as we did many times before. This is because the first constraint is an inequality which is not allowed in the solving method of Lagrange. When the constraints contain an inequality we use the *Kuhn-Tucker conditions*. This is an extension of Lagrange's method and it works practically the same. Although for each inequality  $g_i(x) \leq 0$  we add the conditions that  $\lambda_i g_i(x) = 0$  and  $\lambda_i \leq 0$ .

For (B.2) the Kuhn-Tucker conditions are

$$\left\{ \begin{array}{ll} \mu - 2\lambda_1 \Psi \theta + \lambda_2 \bar{1} = 0 & (a) \\ -\theta^T \Psi \theta \leq 0 & (b) \\ \bar{1}^T \theta - C_0 = 0 & (c) \\ -\lambda_1 \theta^T \Psi \theta = 0 & (d) \\ \lambda_1 \leq 0 & (e) \end{array} \right. \quad (\text{B.3})$$

Suppose  $\lambda_1 = 0$ . Then (a) gives

$$\mu + \lambda_2 \bar{1} = 0$$

from which no feasible solution of  $\lambda_2$  can be determined because we assume that  $\mu$  is not a constant vector (so our assumption means that it is not possible that all the expected returns are the same, which is quite plausible). So  $\lambda_1 \neq 0$  and from (e) we see that  $\lambda_1 < 0$ . Equation (a) gives us an expression for  $\theta$ :

$$\theta = \frac{1}{2\lambda_1} (\lambda_2 \Psi^{-1} \bar{1} + \Psi^{-1} \mu) \quad (\text{B.4})$$

Then from (d) we have, because  $\lambda_1 \neq 0$ , that  $\theta^T \Psi \theta = 0$ , which gives

$$\begin{aligned}\frac{1}{4\lambda_1^2} (\lambda_2 \bar{1}^T \Psi^{-1} + \mu^T \Psi^{-1}) \Psi (\lambda_2 \Psi^{-1} \bar{1} + \Psi^{-1} \mu) &= 0 \\ \Rightarrow \frac{1}{4\lambda_1^2} (c' \lambda_2^2 + 2b' \lambda_2 + a') &= 0\end{aligned}$$

So this gives the quadratic expressions

$$c' \lambda_2^2 + 2b' \lambda_2 + a' = 0 \quad \wedge \quad \lambda_1 \neq 0$$

The latter is true by assumption, the first equation gives the following solution by using the abc-formula:

$$\lambda_2 = -\frac{b'}{c'} \pm \frac{1}{c'} \sqrt{-d'}$$

which only has a solution if  $d' < 0$  (this result is used before). If not, problem (B.2) is infeasible and there is no solution. From (c) and the expression for  $\theta$  we have

$$\frac{1}{2\lambda_1} (\lambda_2 \bar{1}^T \Psi^{-1} \bar{1} + \bar{1}^T \Psi^{-1} \mu) - C_0 = \frac{1}{2\lambda_1} (\lambda_2 c' + b') - C_0 = 0$$



$$\Rightarrow \lambda_1 = \frac{c' \lambda_2 + b'}{2C_0}$$

And by filling in the value for  $\lambda_2$  we are getting

$$\lambda_1 = \frac{c'(-\frac{b'}{c'} \pm \frac{1}{c'}\sqrt{-d'}) + b'}{2C_0} = \pm \frac{1}{2C_0}\sqrt{-d'}$$

Because we know by (e) and  $\lambda_1 \neq 0$  that  $\lambda_1 < 0$ , only the negative value of  $\lambda_1$  is valid. This implies that the  $\pm$  sign in  $\lambda_2$  must also have the negative sign. So

$$\lambda_1 = -\frac{1}{2C_0}\sqrt{-d'} \quad , \quad \lambda_2 = \frac{-b' - \sqrt{-d'}}{c'}$$

Since we have expressions for both  $\lambda_1$  and  $\lambda_2$  we can continue with expression (B.4) for  $\theta$ . This gives

$$\theta_T = \frac{C_0}{\sqrt{-d'}} \left( \frac{b' + \sqrt{-d'}}{c'} \Psi^{-1} \bar{1} - \Psi^{-1} \mu \right)$$

So the (maximized) value for  $\mu_p$  is

$$\begin{aligned} \mu_T &= \mu^T \theta_T = \frac{C_0}{\sqrt{-d'}} \left( \frac{b' + \sqrt{-d'}}{c'} \mu^T \Psi^{-1} \bar{1} - \mu^T \Psi^{-1} \mu \right) \\ &= \frac{C_0}{\sqrt{-d'}} \left( \frac{b' + \sqrt{-d'}}{c'} b' - a' \right) = \frac{b' + \sqrt{-d'}}{c'} C_0 \end{aligned}$$

The last step is to fill in the values for  $b'$ ,  $c'$  and  $d'$  in the above formulas. When doing this, we get the following results

$$\mu_T = \frac{bk_\alpha^2 + d + \sqrt{dk_\alpha^2(a + 2b + c - k_\alpha^2)}}{ck_\alpha^2 - d} C_0$$

and

$$\theta_T = \frac{1}{d} \Sigma^{-1} ((a\bar{1} - b\mu)C_0 + (c\mu - b\bar{1})\mu_T)$$

And it is clear that these results are the same as the results from the intuitive calculations.

## B.2 With risk-free asset

Taking a more analytical approach for solving the maximization problem with risk-free asset gives the following system

$$Max \left\{ \begin{array}{l} \mu_p \geq -C_0 - k_\alpha \sigma_p \\ \Theta_m + \Theta_f = 1 \\ \mu_p = \Theta_m \mu_m + \Theta_f C_0 \mu_f \\ \sigma_p = \Theta_m \sigma_m \end{array} \right\} \quad (B.5)$$

where the objective is to find the proportions which should be invested in the market portfolio ( $\Theta_m$ ) and risk-free asset ( $\Theta_f$ ) to maximize the expected return. This system differs from system (3.2) in a way that it is adjusted to the fact

that the presence of the risk-free asset implies that only combinations of the market portfolio and the risk-free asset will be chosen. We can simplify (B.5) by substituting the expressions for  $\mu_p$  and  $\sigma_p$ , so the shortfall constraint becomes

$$\Theta_m \mu_m + \Theta_f C_0 \mu_f \geq -C_0 - k_\alpha \Theta_m \sigma_m \quad \Rightarrow \quad \Theta_f C_0 \mu_f + \Theta_m (\mu_m + k_\alpha \sigma_m) + C_0 \geq 0$$

Using this, the maximization problem becomes

$$\text{Max} \left\{ \begin{array}{l} \Theta_m \mu_m \\ + \Theta_f C_0 \mu_f \end{array} \left| \begin{array}{l} \Theta_f C_0 \mu_f + \Theta_m (\mu_m + k_\alpha \sigma_m) + C_0 \geq 0 \\ \Theta_m + \Theta_f = 1 \end{array} \right. \right\} \quad (\text{B.6})$$

which can be solved with the Kuhn-Tucker conditions. The K-T conditions are

$$\left\{ \begin{array}{ll} C_0 \mu_f + \lambda_1 C_0 \mu_f + \lambda_2 = 0 & (a) \\ \mu_m + \lambda_1 (\mu_m + k_\alpha \sigma_m) + \lambda_2 = 0 & (b) \\ \Theta_f C_0 \mu_f + \Theta_m (\mu_m + k_\alpha \sigma_m) + C_0 \geq 0 & (c) \\ \Theta_m + \Theta_f = 1 & (d) \\ \lambda_1 (\Theta_f C_0 \mu_f + \Theta_m (\mu_m + k_\alpha \sigma_m) + C_0) = 0 & (e) \\ \lambda_1 \geq 0 & (f) \end{array} \right. \quad (\text{B.7})$$

Suppose  $\lambda_1 = 0$ . Then (a) and (b) together give

$$C_0 \mu_f = \mu_m$$

which cannot be true because  $\mu_m = \frac{a - b\mu_f}{b - c\mu_f} C_0$ , so

$$C_0 \mu_f = \frac{a - b\mu_f}{b - c\mu_f} C_0 \quad \Rightarrow \quad c\mu_f^2 - 2b\mu_f + a = 0$$

which only has solutions for positive discriminant  $4b^2 - 4ac = -4d < 0$ , which clearly contradicts. So it has no solutions and  $\lambda_1 \neq 0$ . But then follows from (e) that

$$\Theta_f C_0 \mu_f + \Theta_m (\mu_m + k_\alpha \sigma_m) + C_0 = 0$$

which results, together with (d), in

$$\Theta_m = \frac{-(1 + \mu_f)C_0}{\mu_m + k_\alpha \sigma_m - C_0 \mu_f}, \quad \Theta_f = \frac{\mu_m + k_\alpha \sigma_m + C_0}{\mu_m + k_\alpha \sigma_m - C_0 \mu_f}$$

Now only condition (f) has to be checked. Because  $\lambda_1 \neq 0$  we must have that  $\lambda_1 > 0$ . From (a) and (b) it follows that

$$\lambda_1 = \frac{C_0 \mu_f - \mu_m}{\mu_m + k_\alpha \sigma_m - C_0 \mu_f}$$

and after substituting  $\mu_m$  and  $\sigma_m$ :

$$\lambda_1 = -\frac{\sqrt{c\mu_f^2 - 2b\mu_f + a}}{k_\alpha + \sqrt{c\mu_f^2 - 2b\mu_f + a}} = -\frac{s}{k_\alpha + s}$$

So (f) is valid if  $\lambda_1 > 0 \Rightarrow (-k_\alpha) > s$ . If not, there is no solution of (B.6). This constraint is quite logic, because it says that the slope of the shortfall line must be greater than the slope of the CML. If it is not, there can not be a point

of intersection because the CML lies above the shortfall line (see the figure in the regular section). Now the expected return is

$$\begin{aligned}\mu_T &= \Theta_f C_0 \mu_f + \Theta_m \mu_m = \frac{-\mu_m + k_\alpha \sigma_m \mu_f + C_0 \mu_f}{\mu_m + k_\alpha \sigma_m - C_0 \mu_f} C_0 \\ &= \frac{k_\alpha \mu_f - s}{k_\alpha + s} C_0\end{aligned}$$

and the standard deviation

$$\begin{aligned}\sigma_T &= \Theta_m \sigma_m = \frac{-(1 + \mu_f) \sigma_m}{\mu_m + k_\alpha \sigma_m - C_0 \mu_f} \\ &= \frac{-1 - \mu_f}{k_\alpha + s} C_0\end{aligned}$$

which are the same results as when the intuitive solution was obtained. So the optimal Telser allocation is given by (3.5).

---

## MATLAB programs

---

This appendix shows the MATLAB programs I used for calculating optimal portfolios using second order cone programming. The SEDUMI package should be installed at the computer for solving the SOCP. The Yalmip package should be installed for successfully implementing the SUDUMI package. With this packages installed, the following programs should work.

### C.1 robustmarkowitz.m

```
function theta = robustmarkowitz(m,S,b,D,ra)

% robustmarkowitz(m,S,b,D,z) calculates optimal investment policy
% with uncertainty when we use the Markowitz criterion.
% b is the deviation vector where for mean vector c we have
% uncertainty structure  $m-b < c < m+b$ 
% D is the deviation matrix where for covariance matrix C we have
% uncertainty structure  $S-D < C < S+D$ 
% ra=parameter of risk aversion

[n,n]=size(S);
A=eye(n+1,n); % hulpmatrix
b=ones(n+1,1)-eye(n+1,n)*ones(n,1); % hulpvector
B=2*S^(1/2); % hulpmatrix
C=2*D^(1/2); % hulpmatrix

x=sdpvar(n,1); % theta
y=sdpvar(n,1); % eta
r=sdpvar(1,1); % rho
```

```
t=sdpvar(1,1); % tau

mt=m';
bt=b';

F=lmi('||A*B*x+(1-r)*b||<1+r'); % define constraints
F=F+lmi('||A*C*y+(1-t)*b||<1+t'); % constraint
F=F+lmi('ones(1,n)*x==1'); % constraint
F=F+lmi('y-x>0')+lmi('y+x>0') % constraint

solvesdp(F,[],-mt*x+bt*y+0.5*ra*r+0.5*ra*t) % solve

theta=double(x); % the optimal allocation
```

## C.2 robusttelsr.m

```
function theta = robusttelsr(m,S,b,D,z,VarR)

% robusttelsr(m,S,b,D,z,VarR) calculates optimal investment
% policy with uncertainty.
% b is the deviation vector where for mean vector c we have
% uncertainty structure m-b < c < m+b
% D is the deviation matrix where for covariance matrix C we
% have uncertainty structure S-D < C < S+D
% z = quantile of VaR constraint
% VaR = limit Value at Risk

[n,n]=size(S);

mt=m';
bt=b';

x=sdpvar(n,1); % theta
y=sdpvar(n,1); % phi
r=sdpvar(1,1); % rho
t=sdpvar(1,1); % tau

B=S^(1/2); % hulpmatrix
C=D^(1/2); % hulpmatrix

F=lmi('||B*x||<r'); % define constraints
F=F+lmi('||C*y||<t'); % constraint
F=F+lmi('||[1;0]*r+[0;1]*t||<1/(-z)*(mt*x-bt*y+VarR)');
F=F+lmi('ones(1,n)*x==1'); % constraint
F=F+lmi('y-x>0')+lmi('y+x>0') % constraints

solvesdp(F,[],-mt*x + bt*y); % solve

theta=double(x);
```

### C.3 robustmarkowitz2.m

```
function theta = robustmarkowitz2(m,S,g)

% robustmarkowitz2(m,S,g)
% calculates the optimal Markowitz portfolio with
% parameter uncertainty in the covariance matrix.
% S = all covariance matrices pasted below each other
% m = mean vector
% g = parameter of risk aversion

[rows,n]=size(S);

A=eye(n+1,n); % hulpmatrix
b=ones(n+1,1)-eye(n+1,n)*ones(n,1); % hulpvector
number_matrices=rows/n; % number of cov. matrices
mt=m';

x=sdpvar(n,1); % theta
r=sdpvar(1,1); % rho

F=lmi('ones(1,n)*x==1'); % budget constraint

for k=1:number_matrices
    T=S((k-1)*n+1:k*n,1:n); % m covariance matrices
    B=2*T^(1/2); % hulpmatrix
    F=F+lmi('||A*B*x+(1-r)*b||<1+r'); % m constraints
end

solvesdp(F, [], -mt*x+0.5*g*r) % solve

theta=double(x);
```

### C.4 robusttelsler2.m

```
function theta = robusttelsler2(m,S,z,VaR)

% robusttelsler2(m,S,z,VaR) calculates optimal investment policy
% with uncertainty.
% S = all possible covariance matrices pasted below each other
% m = mean vector
% z = standardized quantile of (elliptical) distribution of
% VaR constraint.
% VaR = VaR limit

[rows,n]=size(S);

number_matrices=rows/n; % number of covariance matrices
mt=m';
```

```
x=sdpvar(n,1); % theta

F=lmi('ones(1,n)*x==1'); % budget constraint

for k=1:number_matrices
    T=S((k-1)*n+1:k*n,1:n); % m covariances
    B=T^(1/2); % hulpmatrix
    F=F+lmi('||B*x||<1/(-z)*(mt*x+VaR)'); % m constraints
end

solvesdp(F,[],-mt*x); % solve

theta=double(x);
```