



Universiteit  
Leiden  
The Netherlands

## Edge damage on Châtelperroonian points from Quinçay(France)

Versluis, June

### Citation

Versluis, J. (2024). *Edge damage on Châtelperroonian points from Quinçay(France)*.

Version: Not Applicable (or Unknown)

License: [License to inclusion and publication of a Bachelor or Master Thesis, 2023](#)

Downloaded from: <https://hdl.handle.net/1887/3767039>

**Note:** To cite this publication please use the final published version (if applicable).



# Edge damage on Châtelperronian points from Quinçay; (France)

June Versluis

BA THESIS Leiden University

# **Edge damage on Châtelperronian points found in Quinçay, France**

Author: June Versluis

Course: BA Thesis

Course code: 1083VBTHEY

Student number: s3109003

Supervisors: Dr. Alexander Verpoorte & Prof. Dr. Marie Soressi

Leiden University, Faculty of Archaeology

Den Haag, 01/05/2024

Version 4

*Photo on front cover:*

*Châtelperronian points yielding from layer En in section SAG1, Quinçay. (Photo by author J. Versluis)*

# Preface

Dear reader,

These past few months have been occupied with research, meaningful conversations, gaining knowledge, reading, measuring edge angles, observing, rocks and the occasional breakdown. The thesis presented before you is the end result of this work, of which I cannot be anything else but proud. These last three years I was lucky enough to deep dive into archaeology and explore my passion. I am very thankful for all the help I have had and the people I have met during this journey.

First of all, I want to thank my family's unconditional support, even though my work confused them at times. Furthermore, thank you Alexander Verpoorte for all the great, constructive, feedback and helpful conversations when I felt stuck in my research. Most importantly, thank you for making me passionate about Palaeolithic archaeology ever since the very first course of the bachelor.

To the Human Origins team at the faculty, the Quinçay excavation team and, specifically, Areti, Igor, Tullio and Vincent: Thank you for answering all my silly questions, the big support, the helpful tips and fun conversations. I appreciate all your involvement and am glad we got to share a workspace. Areti and Igor, I greatly value the help I have received from you on constructing the database, interpreting the Châtelperronian points and on understanding site formation processes. This thesis would not have looked this way without you, and I am thankful that your doors were always open to my questions.

Also, un grand merci to Marie Soressi without whom this thesis would not have existed. I am very grateful for the opportunities she has offered me, and inspired by the enthusiasm and passion she puts in her work. She has always been supportive and am thankful that she entrusted me with her data and research.

Finally, Raphaël. Thank you. I appreciate you the most.

I hope you enjoy the thesis presented below, as I thoroughly enjoyed making it.

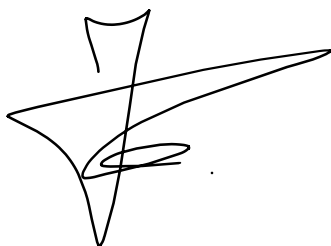
A handwritten signature in black ink, consisting of a stylized, abstract shape with a long horizontal stroke extending to the right and a vertical stroke intersecting it.

June Versluis.

# Table of Contents

<b>1. Introduction</b> .....	<b>4</b>
1.1 Characteristics of the Châtelperronian.....	4
1.2 The associated hominins.....	5
1.3 Relevance of research.....	6
<b>2. Processes that lead to edge damage on lithic artefacts</b> .....	<b>7</b>
2.1 Site formation processes.....	7
2.2 Solifluction.....	8
2.3 Cryoturbation.....	9
<b>3. Materials</b> .....	<b>13</b>
3.1 La-Grande-Roche-de-la-Plématrie, Quincay, France.....	13
3.2 Stratigraphy.....	15
3.3 Studied material.....	18
<b>4. Methodology</b> .....	<b>20</b>
4.1 Basic artefact description.....	20
4.2 Degrees of edge damage.....	21
4.3 Edge angle analysis.....	23
<b>5. Results</b> .....	<b>25</b>
5.1 Measurements.....	25
5.2 Raw material.....	30
5.3 Fragment type.....	32
5.4 Type of edge damage.....	33
5.5 Position of taphonomic removals.....	36
5.6 Number of taphonomic removals.....	37
5.7 Size of largest removal.....	38
5.8 Rounding.....	40
5.9 Percentage of lateral edge affected.....	41
5.10 Edge angle analysis.....	43
5.11 Steepest affected angle.....	45
<b>6. Discussion</b> .....	<b>46</b>
6.1 Comparing the layers.....	46
6.2 The hypotheses.....	47
<b>7. Conclusion</b> .....	<b>51</b>
<b>8. Abstract</b> .....	<b>53</b>
<b>9. Bibliography</b> .....	<b>54</b>

## 1. Introduction

Comprehension of the stratigraphic layers at any site is vital to understanding the complex history of its formation and occupation. Site formation processes can cause disturbance in the different stratigraphic deposits, which complicates interpretation of archaeological layers. These natural factors do not only exert influence on the site formation, but also on the level of preservation and the state of artefacts residing within these deposits.

La-Grande-Roche-de-la-Plématrie (henceforth referred to as Quinçay, after the township) is a site where the understanding of taphonomic processes altering the stratigraphic layers is key. The site was occupied during the Middle to Upper Palaeolithic transition ca. 50,000 to 40,000 years ago. This is a crucial time period that is characterised by the replacement and mixing of the local Neanderthal population with expanding groups of anatomically modern humans (AMH) (Green et al., 2010, p. 721; Hublin et al., 2012, p. 18743; Roussel et al., 2016, p.14; Soressi & Roussel, 2014, p. 2680). This event coincides with cultural changes in the archaeological record. Transitional technological industries succeed the late Middle Palaeolithic, with the Châtelperronian industry being one of the most iconic (Soressi & Roussel, 2014, p. 2681; Hublin, 2015, p. 200). The site in Quinçay is known for having a sequence of multiple overlying layers attributed to the Châtelperronian lithic industry. These deposits have been protected due to the collapse of large limestone slabs, which has prevented the layers from mixing with later occupations (Roussel et al., 2016, p. 14). The presumed absence of mixing makes the Quinçay sequence critical for understanding the Middle to Upper Palaeolithic transition in Europe, as well as the level of contact between late Neanderthals and anatomically modern humans in the area.

### 1.1 Characteristics of the Châtelperronian

The Châtelperronian (CP) is found throughout France and the north of Spain and is characterised by volumetric blade reduction, curved back blades, end-scrapers, bladelets, bone tools and ornaments (Ruebens et al., 2015, p. 56). This industry follows the Mousterian, which characterised by a flake based industry, usually. Blade production has been found at a number of sites linked to the Mousterian, these blades differentiate themselves from the Châtelperronian blades by almost never being retouched (Roussel et al., 2016, p. 27). One of the rare artefacts yielding from the deposits at Quinçay are pierced teeth, which might as well be among the oldest ornaments found in Europe. Dating to ca. 50,000 to 40,000 years ago and succeeded by the Aurignacian (Soressi & Roussel, 2014, p. 2681; Hublin et al., 2012, p. 18743) this industry is at a crossroad of debate. One part of the debate, which has been largely resolved, questions whether the industry can be considered as separate from other early Upper Palaeolithic cultures. Original discoveries of the CP techno-complex were presumed to represent the first stage of the Upper Palaeolithic, alongside the Mousterian of Acheulean industry, which now has been attributed to the Middle Palaeolithic (Breuil, 1909-1911 as cited in

Soressi & Roussel, 2014, p. 2680). Later the Châtelperronian was suggested to be the precursor to the Gravettian (Peyrony, 1936 as cited in Soressi & Roussel, 2014, p. 2681). However, the small scale variability found within the artefacts, together with specific characteristics have established the culture as a separate industry (Delporte, 1954, as cited in Soressi & Roussel, 2014, p. 2681; Pelegrin, 1995 and Connet, 2002 as cited in Roussel et al., 2016, p. 26; Hublin, 2015, p. 200), of which the early identifications were based on typological grounds before the introduction of absolute dating techniques.

## **1.2 The associated hominins**

Another debate remains ongoing regarding the makers of the Châtelperronian. This question has been the source of many theories regarding late Neanderthal and AMH interactions in Eurasia. The earliest arrival of AMH into Europe has been dated to at least 47,000 to 45,000 years cal. BP, possibly extending as far back as 54,000 years cal. BP (Fewlass et al., 2020, p. 799; Prüfer et al., 2021, p. 823). Worldwide, this would mean that there was a possible overlap of the two species up to 14,000 years (Hublin et al., 2020, p. 301) and an overlap between 2600 to 5400 years in Europe (Higham et al., 2014, p. 306). New results also suggest that the arrival of AMH in Europe precedes the disappearance of Neanderthals and the CP by up to 1400 to 2900 years (Djakovic et al., 2022, p. 8), what this indicates for the degree of interaction between the two species remains unsolved, however there was much time for an alleged exchange of cultural and symbolic behaviours, as well as genetics.

Due to a discovery of CP artefacts seemingly in the same context as Neanderthal remains at Saint-Césaire (Vandermeersch, 1984, p. 195) and Grotte du Renne (Hublin et al., 1996, p. 224) in France, it was argued that Neanderthals were the makers of the CP. However, revision of the taphonomic and spatial, typo-technological data and radio-carbon dates suggest the admixture of assemblages and questions the Neanderthal association (Gravina et al., 2018, p. 8; Higham et al., 2010, p. 20239). Another dating study supports the integrity of the stratigraphic sequence at Saint-Césaire, discrediting the admixture hypothesis with new radiocarbon dates (Hublin et al. 2012, pp. 18743–18748). Furthermore, a direct date is also provided for the Neanderthal CP skeleton from Saint-Césaire which links the CP assemblages to late Neanderthals in western Europe. The dates indicate that the making of bodily ornaments postdates the arrival of AMH in the area (Hublin et al., 2012, p. 18743). Indicating that the presence of ornaments in the CP could be the result of cultural admixture and diffusion from AMH to Neanderthals. The admixture hypothesis is the reason that Quinçay is a key site for the debate. No mixing with further occupation was thought to have occurred due to the collapse of large limestone slabs (Roussel et al., 2016, p. 14). However, recent excavations initiated in 2019 have resulted in a re-interpretation of the artefacts yielding from the most recent layers in the front of the cave, of which some are now being attributed to the proto-Aurignacian industry (Soressi et al., 2023, p. 34). Furthermore, the admixture might be greater than assumed due to site formation

processes. The importance of assessing the degree of sedimentary mixture in order to evaluate cultural admixture is crucial.

### **1.3 Relevance of research**

The aim of this research is to gain insight into site formation processes at play at La-Grande-Rochede-la-Plématrie, Quinçay, by a study of edge damage on the Châtelperronian points.

The CP points are found in three layers: layers En, Em and Ej. One hypothesis is that the CP points found in the three layers have been deposited in one single layer, but were significantly moved and damaged due to site formation processes altering and disturbing the stratigraphic layers. On the other hand, it could be the case that the CP points are actually in situ in the three layers. In that case, the CP points yielding from the upper layer, which have been sealed by a collapse of the roof for 25,000 years (M. Soressi personal communication, May 2024), and can be dated to sometime between 42,000 and 39,700 modelled years ago by correlation to the proto-Aurignacian industry (Barshay-Schmidt et al., 2018, p. 835; Banks et al., 2013, p. 816) suggest that the Châtelperronian period could have lasted longer than previously thought (Djakovic et al., 2022, p. 4).

The questions this thesis seeks to answer are as follows

1. What type and degree of edge damage is found on the CP points in layers En, Em and Ej?
2. How do the differences and/or similarities of edge damage characterise the three different layers?  
What patterns become obvious?
3. In which way does the degree of damage found in the layers relate to site formation processes?

This thesis will refer to “layers”, indicating a natural stratigraphic and depositional unit. These layers are defined based on colour, texture or contents. “Section” discusses different archaeological layers in sequence in the vertical plane. Finally, “assemblage” refers to a sample or group of artifacts from an archaeological layer or section (Villa, 1982, p. 277).

In the following chapters the information necessary for answering these questions will be provided. The next chapter will focus on which site formation processes can lead to edge damage. Afterwards the site of Quinçay will be discussed in more detail, including the relevant stratigraphy and main find material. Chapter four will discuss the methodology for describing and documenting edge damage on the CP points, of which the results will be presented in chapter five. Finally, the results will be reviewed in more detail, in which scenarios will be discussed regarding explanations for the damage on the CP points. Furthermore, there will be suggestions for further research and a return to the research questions.



## **2. Processes that lead to edge damage on lithic artefacts**

After an artefact has been deposited, it belongs to the realm of taphonomy in which processes are free to alter its state and level of preservation (McBrearty, 1998, p. 109). Lithic artefacts are some of the most common remains recovered from Palaeolithic sites, which can easily fall victim to being redistributed and damaged by post-depositional processes (Bustoz-Pérez & Ollé, 2023, p. 2). Though not all geological processes will lead to damage, the presence of edge damage on artefacts can be an indicator of movement in the soil, with damage being especially prevalent on the edges of lithic artefacts where they are the thinnest and sharpest (McPherron & Dibble, 2006, p. 9). To correctly interpret an assemblage it is of importance to understand the processes shaping a site that may have influenced the state an artefact is in when found. This chapter aims at describing the different taphonomic processes that can affect the preservation and provenance of artefacts. Recognizing the different processes at play can only improve the understanding of a site and lithic assemblage. Furthermore, a more in depth explanation will be provided regarding the two most prominent processes altering Quinçay. An understanding of these processes and their effect on displacement and preservation of artefacts will shed light on the degree of damage and distribution found on the lithic assemblage studied in this thesis. It will become clear how these site formation processes may have displaced artefacts which were originally deposited in one layer, but got redistributed over separate layers.

### **2.1 Site formation processes**

The term ‘site formation processes’ was first introduced by Schiffer (1972, p. 163), who proposed the responsibility of cultural and natural transformation processes (C- and N- transforms) for the alteration of the systemic context, which relates to the original behaviour associated with artefacts of past cultural systems, into the archaeological context. C-transforms encompass the deposition of man-made artefacts which adds to the formation of a site. N-transforms are processes that alter, disturb and destroy the original stratigraphic layers and aid in the displacement of the soil patterns (Schiffer, 1972, p. 157). These type of transformations are usually lumped together using the term ‘diagenesis’, which encompasses all transformations that take place in sediment post-depositionally. Diagenesis is defined by chemical and mechanical transformations to the soil (Karkanas & Goldberg, 2019, p. 17), and is particularly invasive at sites with a large amount of organic matter where water easily permeates the soil, causing the sediment to be saturated by water.

Much taphonomic research has been conducted to determine the different diagenetic factors that impact the preservation of artefacts. These processes can influence the understanding of an assemblage, with fractures often being misinterpreted as intentional retouch (McBrearty, 1998, p. 109). Post-depositional alterations depend on different factors, the type of processes an artefact encounters and the degree to which an artefact gets exposed to these processes the moment it enters

the archaeological record (Bustoz-Pérez & Ollé, 2023, p. 2). In edge damage studies, there has been a large focus on fluvial action as well as human and/or animal trampling impacting stone flakes (Bustoz-Pérez & Ollé, 2023, p. 2; Gifford-Gonzalez, 1985, pp. 803-817; McBrearty, 1998, pp. 108-125; Tringham, 1974, pp. 171-196). Lithics in a fluvial context are characterised by particle transport. They can themselves be subjected to transport, or be affected by particles moving along their surface. The three most commonly described modes of particle transport are rolling, sliding and saltation (Alhusban & Valyrakis, 2021, p. 1; Bustoz-Pérez & Ollé, 2023, p. 2). Previous work on trampling has focused on how the process causes displacement of artefacts, how it causes randomly distributed damage and how it may inflict damage resembling retouch or use wear (Gifford-Gonzalez, 1985, pp. 803-817; Tringham, 1974, pp. 171-196; McBrearty, 1998, p. 110). Trampling is an important issue for the interpretation of artefact edge damage in archaeological context, and a very common phenomenon at many sites (Bordes & Bourgon, 1951, as cited in McBrearty, 1998, p. 110). Moreover, paedogenic processes altering the soil together with elements like groundwater, soil composition, growth of plants, burrowing animals and presence of human activity have been noted to play a large role in altering the structure of a site and the state of artefacts (Bocek, 1986, p. 601; Gifford-Gonzalez, 1981, pp. 365-438; Rowlett & Robbins, 1982, p. 81; Van Vliet-Lanoë, 1985, p. 118; Villa, 1982, pp. 278-279). At Quinçay, the stratigraphy has mainly been altered and disturbed by paedogenic processes related to frost action, which is common in the periglacial climate of the late Pleistocene (Soressi et al., 2023, p. 87; Karkanas & Goldberg, 2019, p. 80).

The two most prominent frost action related processes present at Quinçay are those of solifluction and cryoturbation (Soressi et al., 2023, p. 87). All artefacts have been at the surface at their moment of deposition, thus the effects of trampling also need to be considered when interpreting the assemblage. However, trampling will not have played a large role in the vertical displacement of the assemblage. Furthermore, the humid conditions and occupation of bats in the cave, and subsequent presence of guano, have left the site exposed to chemical diagenesis (Soressi et al., 2023, p. 77; see Karkanas & Goldberg, 2019, p. 78 for general explanation of the process). Below solifluction and cryoturbation will be dealt with in more depth.

## **2.2 Solifluction**

Solifluction is a phenomenon in the soil which is most importantly controlled by slope gradient, water supply and freeze-thaw action (Van Vliet-Lanoë, 1998, p. 167; Burrone et al., 2002, p. 1280). It is the collective name for the slow periglacial soil movements that are frost creep, gelifluction and frost heave (Karkanas & Goldberg, 2019, p. 40; Lenoble et al., 2008, p. 100). The definition by Harris et al. (1997, p. 849) explains solifluction as a process typical for periglacial environments, in which soil gets misplaced while it moves down a slope in a slow, creeping tempo. Occurring over long periods of time, it ultimately results in lithic assemblages becoming scattered, with a preferred orientation for

artefacts at the bottom of a slope (Burroni et al., 2001, p. 1280; Lenoble et al., 2008, p. 101). The multiple processes which disrupt the soil include: (1) the lifting of the soil by cyclic frost heaving, alternated by thawing which causes the sediment to move downwards (frost creep); (2) forming of needle ice at surface of soil which heaves, and slowly moves, stones (frost heave); and (3) the large scale displacement of thawing water-saturated sediment (gelifluction) (Lenoble et al., 2008, p. 100). The process of freezing and thawing create typical stratified slope deposits, which are characterised by poor sorting and a coarse bedding (Karkanias & Goldberg, 2019, p. 42).

### **2.2.1 Causes of damage**

An experiment performed by Lenoble et al. (2008, pp. 99-110) wishes to document the movements and disruption archaeological assemblages are exposed to during the process of solifluction, specifically at Palaeolithic sites in France. Using the TRANSIT program, which is designed to record modification caused by periglacial processes, they found that solifluction causes the artefacts to be less densely sorted, and gives the entire assemblage an elongated shape after 100-200 years, with a random distribution being reached after 400-500 years. Additionally, they suggest that a concentration of artefacts, as well as a high refitting rate of lithics, cannot be seen as clearcut evidence for a lack of site distortion. Burroni et al. (2002, p. 1280) experimentally simulated the affect of soil movement on chert flakes using a tumbling machine. During their experiment they found that the larger the grain size of the substrate, as well as of the flake itself, the higher the increase in damage. Furthermore, they found that the damage increases as time increased, and when the sediment is saturated. Wet sediment resulted in a higher degree of rounding of the edge and micro-fractures along the edges of a flake.

Though the processes of solifluction might occur much slower compared to trampling and fluvial action, because they take place repeatedly, and over a very long time, solifluction ultimately affects a very large percentage of artefacts while also causing fractures along the edges of artefacts due to movement in wet sediment (Burroni et al., 2002, p. 1280; Lenoble et al., 2008, p. 109). This can lead to a random distribution of a lithic assemblage deposited together at the same moment in time.

### **2.3 Cryoturbation**

Solifluction is often found in the same location and context as cryoturbation (Van Vliet-Lanoë, 1998, p. 167). First, it is important to note that the invasiveness and presence of cryoturbation, more specifically the formation of ice lenses, is dependent on the appropriate sediment and climatic conditions. The presence of water is the most important (Washburn, 1979 as cited in Van Vliet-Lanoë, 1998, p. 157). Additionally, fluctuating temperature ratios, high humidity, permeability of the soil, pressure and steady water supply are all elements that play a vital role in the presence of cryoturbation at a site. Saturated, heterogenous, loamy textured sediments provide the best conditions for the formation of ice crystals (Van Vliet-Lanoë, 1985, p. 118). Grain size is a crucial factor impacting the

freezing process, in which larger grain sizes require colder temperatures to freeze. Soils that consist mainly of clay and silt sized particles will be much more prone to frost action compared to sand sized particles. Large grains will prohibit the movement of water and stop water from collecting (Washburn 1980, as cited in O'Brien, 2006, p. 5).

When the temperature drops below zero degrees, and the conditions are right, ice lenses will start to take form in the capillary fringe of a water table. The ice lenses will form serially in medium-sized pores. Here they will continue to grow, as long as the pore-water pressure remains high enough, even after the capillary feed is blocked (Van Vliet-Lanoë, 1985, p. 119). This formation heaves the sediment, subsequently causing invasive disruptions in the soil, leading to cryogenic features that include injections, folds, involutions, frost cracks and wedges. This also leads to the stratigraphy becoming patterned and drop-like shaped (Fig. 1) (Karkanias & Goldberg, 2019, p. 81; Van Vliet-Lanoë, 1985, p. 145).

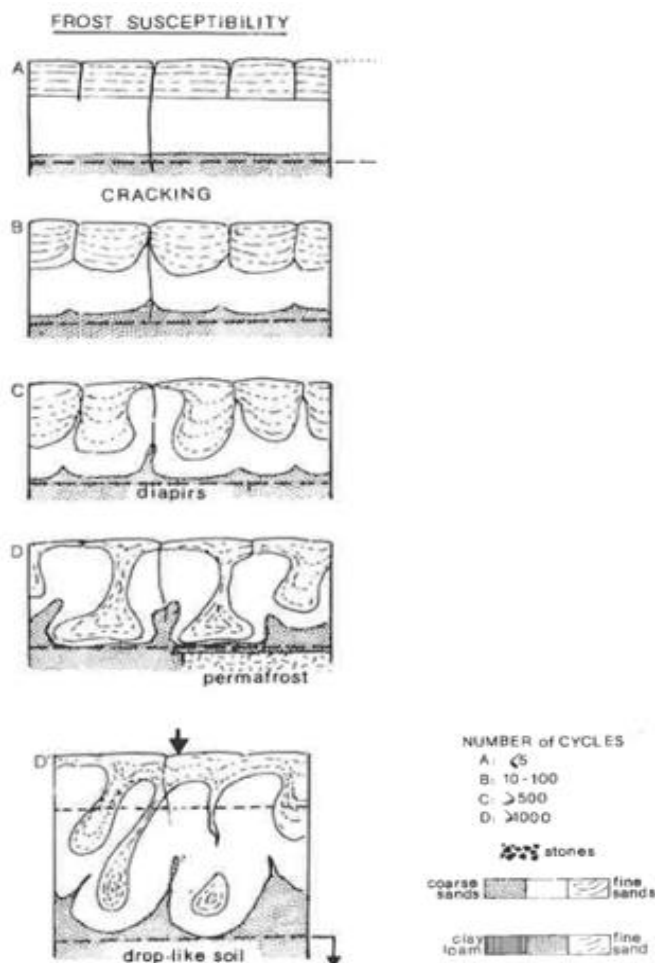

Figure. 1. The patterning of the stratigraphy into drop-like shapes, after Van Vliet-Lanoë, 1985, p. 145

The sequential formation of ice lenses, and ensuing soil heaving, will lead to the replacement and sorting of stones (Fig. 2) (Van Vliet-Lanoë, 1985, p. 126). The first process to take place is that of vertical uplift. This is especially effective on elongated flat stones, like lithic artefacts, causing them to become vertical when slightly tilted. The surface of the elongated flat stones have high adhesivity to the frozen sediment. When a stone is moved it causes increased permeability of the soil which again promotes the saturation and formation of ice lenses.

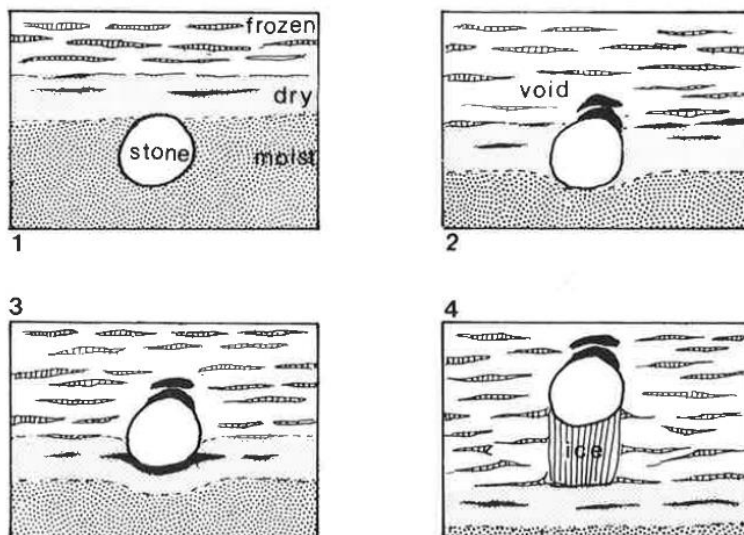

Figure. 2. Process of vertical uplift of a stone caused by cryoturbation taken from Van Vliet-Lanoë, 1985, p. 126, after Kaplar, 1965

### 2.3.1 Causes of damage

Viklander (1998, p. 141-152) found that the ratio of the void volume compared to the volume of a solid substance is a key parameter for whether a stone will move upward or downward in the matrix. In loose soil, with a high void ratio, the stone was more prone to move downward. When the soil became dense due to cyclic freezing and thawing, and the void ratio became low, the stone would heave upward. Interestingly, in the loose soil stones were also more prone to move rotationally and horizontally. In his experiment the stones are exposed to 10 freezing cycles showing a net movement with an average of 5,5 mm and standard deviation of 3,4 mm (Viklander, 1998, p. 145). When a stone enters the archaeological record it is in constant contact with the surrounding matrix, and when it gets exposed to this for a long period of time, say over 25,000 years, the contact can be very invasive. Freeze-thaw cycles and motions in all directions cause artefacts to become increasingly damaged due to the sorting of sediment, as well as by contact with other stones being subjected to the same process. Thus frost heaving causes artefacts to be moved higher than their original position of deposition, the more an artefact is moved the larger the amount of damage will be (Fig. 3)

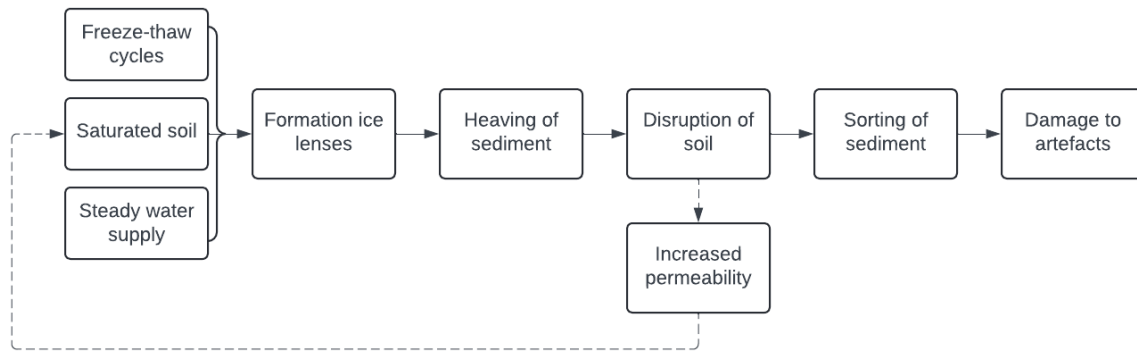

Figure. 3. The process of cryoturbation and how it affects artefacts. (Figure by the author J. Versluis)

Common in prehistoric caves, such as Quinçay, is the repeated freezing of the pore water in the limestone bedrock. Leading to fracturing and spalling of the cave walls, this process results in the deposition of thick accumulations of frost-shattered detritus clasts known as *éboulis*, (Turk & Turk, 2010, p. 3278) which can also sometimes themselves be cryoturbated (Karkanas & Goldberg, 2019, p. 81). In Upper and Middle Palaeolithic rock shelters in southwestern France occupational layers are often separated by sterile zones of *éboulis* detritus, which sometimes ends up including a few artefacts (Rowlett & Robbins, 1982, p. 73). These artefacts are quite fractured, due to being exposed to movement by cryoturbation. Such frost-shattered clast deposits characterise the uppermost layer from which artefacts yield at Quinçay. The number of artefacts in this layer are limited compared to the other layers and appear heavily damaged.

The processes of solifluction and cryoturbation can have a strong influence on the degree of damage and redistribution of artefacts when deposited in periglacial soils. Frost action can alter the way a site and its assemblages are interpreted, thus it is very important to be aware of these phenomena and the way they affect the degree of damage, disruption and the heaving of soil. Understanding the affect of these taphonomic processes on site formation is crucial when attempting to comprehend the CP assemblage at Quinçay. The mechanics of the abovementioned processes aid in providing an explanation for the degree of damage and distribution of the lithic artefacts yielding from the three layers. Furthermore, it sheds light on how these artefacts may have all yielded from a single layer but were redistributed and damaged over three separate layers by slow and random replacement (solifluction) and frost heaving (cryoturbation).

### **3. Materials**

The material studied in this thesis was excavated at the site of La-Grande-Roche-de-la-Plématrie, Quinçay, France of which all belong to the Châtelperronian lithic industry. First, a relay of the background information necessary for understanding the site will be presented. This information will contain the site's excavation history, geology and archaeological importance. Followed, by a detailed description of the section Sagittal 1 (SAG1) as interpreted by the original excavator. It is out of this section that the CP points forming the basis of this analysis yield.

#### **3.1 La-Grande-Roche-de-la-Plématrie, Quinçay, France.**

Material used for analysis in this thesis yield from the Palaeolithic cave site of La-Grande-Roche-de-la-Plématrie near Quinçay. The cave is situated at 110 metres above sea level (NGF) in a south-west oriented, small and dry valley slope in the Auxence region about 15 kilometres north of Poitiers (Fig. 4). The cave has been incised into the limestone wall where it now borders on the Vouillé-Saint-Hilaire national forest. Its formation originates in the Middle Bajocian time period during the Jurassic Period, ca. 169 million years ago (Soressi et al., 2023, p. 15; Soressi et al., 2023, p. 77).

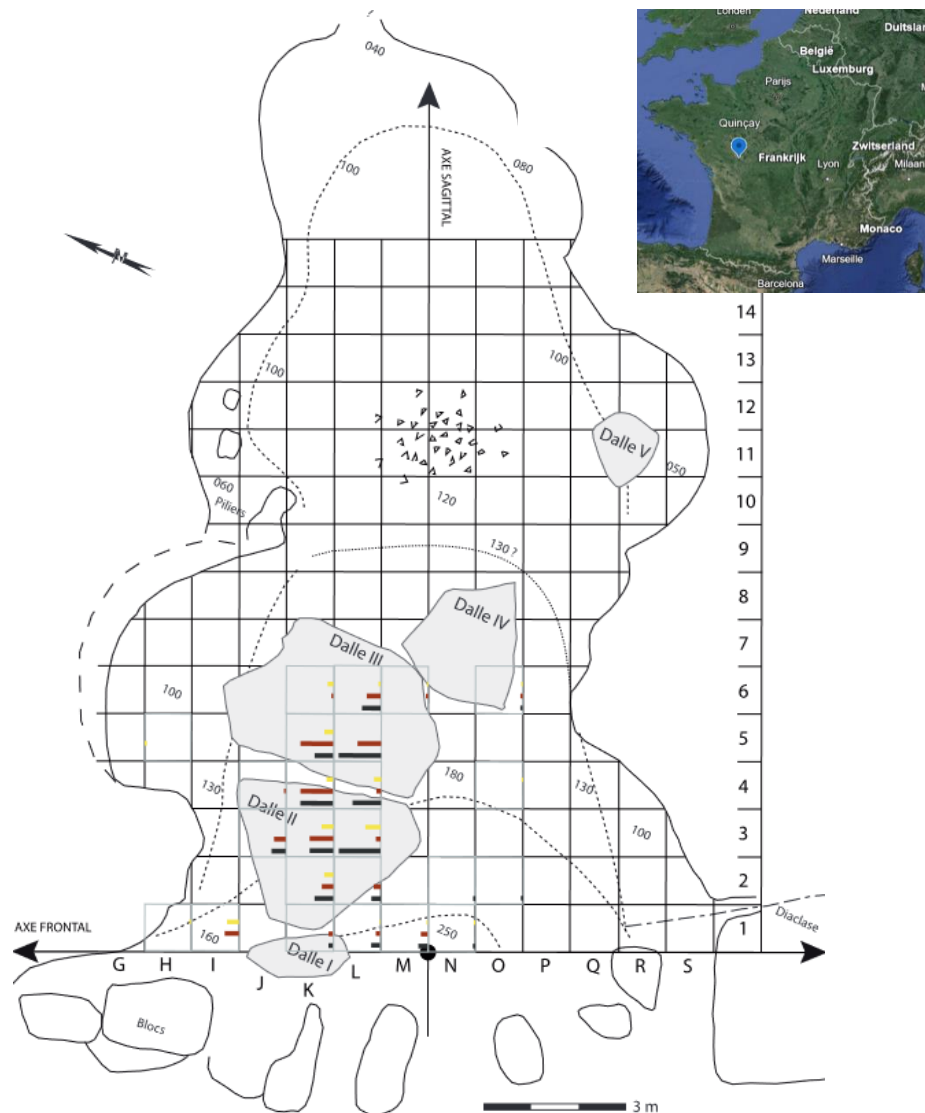

Figure 4. Location of the site in France and plan of Quinçay cave. The “Dalles” indicate the position of the fallen limestone slabs. The coloured bars indicate the number of finds per layer in a specific square in quantities. The black bar represents layer En, the brown bar represents layer Em and the yellow bar represents layer Ej. After Soressi & Roussel (2010, p. 205)

The cave consists of a single chamber which is about 20 metres long with an opening of ca. 14 metres wide. In the limestone formation there is an abundance of flint nodules, which are easily visible. The site was first recognised by Heily & Decron in 1952 (Heily & Decron, 1954, as cited in Soressi et al., 2023, p. 15) and was excavated by Francois Lévêque from 1968 to 1990. He divided the cave into two sections: the back section (partie postérieure), and the front section (partie antérieure). The front section is characterized by the fallen limestone slabs which ended further occupation of the site (Roussel et al., 2016, p. 14). New excavations were started in 2019, directed by Prof. Soressi. Lévêque’s interpretation of the layers have been re-evaluated since the new excavation campaign has started. He had interpreted the assemblages as containing a progression of the techno-complex,



moving from the bottom to the upper layers the industry developed from an early, to an evolved and finally to a regressive stage of the CP (Lévêque & Miskovsky, 1983, pp. 369-391) . Though the lithic artefacts are still considered as belonging to the CP industry, the interpretation of evolution of the techno-complex no longer applies after reinterpretations by M. Soressi and M. Roussel (Roussel & Soressi, 2010, p. 205). The artefacts from the bottom most layer, Eg, have been reclassified as belonging to the Mousterian of Acheulean tradition (Roussel & Soressi, 2010, p. 208). Layers En, Em and Ej are considered as being a technologically homogenous CP (Roussel & Soressi, 2010, p. 213). However, layer Ej has been subject to discussion. Several artefacts yielding from this layer are now interpreted as belonging to the Aurignacian tradition, instead of the CP (Soressi et al., 2023, p. 34).

### **3.2 Stratigraphy**

The limestone bedrock at the base of the stratigraphic sequences, underlying layer Er (Fig. 7), has clearly been altered by phosphatic processes. The state of the limestone clasts in the cave, and the presence of strong alteration and even destruction, indicates the post-depositional exposure of the bedrock to episodes of very high acidity. This acidity does not originate in paleoenvironmental modifications from outside the cave, exogenous run-off or a sulphur-rich geology (Soressi et al., 2023, p. 77) but seems to be something taking place inside of the cave. Bat remains have been found in these stratigraphic sequences, and bats still occupy the cave today. This indicates that the presence of bats have caused the high levels of acidity, and explain the large absence of faunal remains throughout the stratigraphy. Sedimentological analyses carried out by F. Lévêque has pointed out the presence of leucophosphite and goethite in the lower levels of the site. The former of these is shaped by a reaction between bat or bird guano and iron-bearing minerals. It seems that the alteration of the bedrock and sadly the absence of fauna can be explained by the acidity resulting from the accumulation of guano, and the presence of bats in general throughout the history of the site (Soressi et al., 2023, p. 77).

When Lévêque first started excavations at Quinçay he divided the stratigraphy in the cave based on notable differences in colour, texture and overall structure. He interpreted the layers as consisting of five main archaeological units, dividing them into more sublayers within the main units (Fig. 5). This section is known in the present day excavations as Sagittale 1 (SAG1).

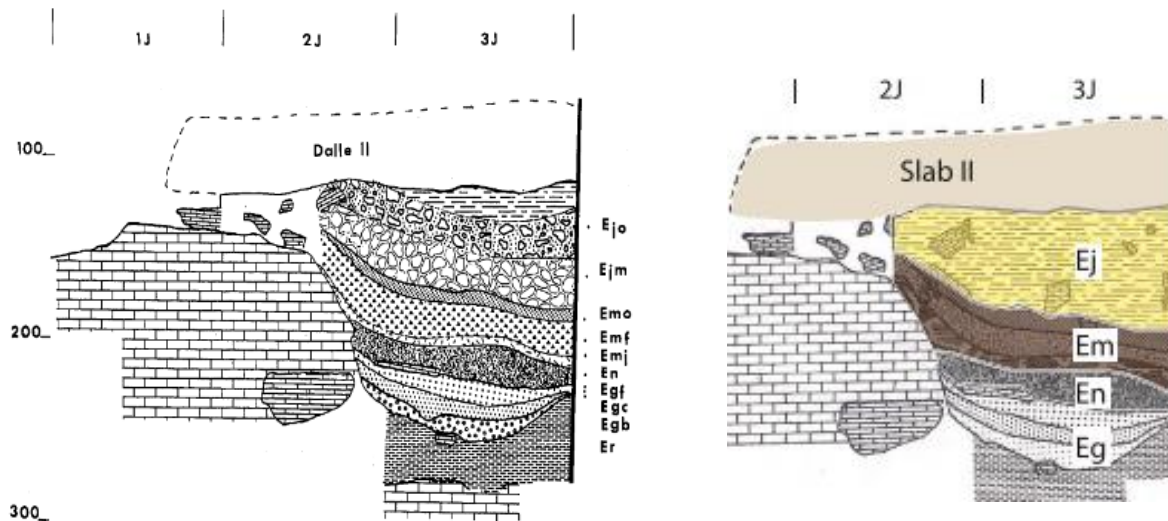

Figure 5. Stratigraphic sequence of Lévêque's Ensemble area (left) (Lévêque & Miskovsky, 1983, p. 372) with a simplified version (right) (Roussel et al., 2016, p. 15)

The oldest to youngest layers, as defined by Lévêque, are explained below (Lévêque & Miskovsky, 1983, pp. 369-391).

### Ensemble Rouge (Er)

The most underlying layer is quite sandy and red of colour. This deposition was interpreted as being mainly archaeologically sterile, with the presence of just a few flint nodules.

### Ensemble Gris (Eg)

This sandy-clayey layer is gray of colour and strongly corroded in general. The sediment is fine-grained, which was interpreted as the result of decomposing limestone clasts (Djakovic, 2021, p. 38). This layer has been sub-divided into three layers: Eg-f, Eg-c, Eg-b due to small changes in sedimentary texture and colour. Lévêque has interpreted this layer as containing an archaic version of the Châtelperronian industry, however recent interpretations, together with new excavations, have been reclassified as belonging to the Mousterian of Acheulean techno-complex (Roussel & Soressi, 2010, p. 208)

### Ensemble Noir (En)

This layer is very dark brown/black of colour, which is very different from the other layers. The colour is interpreted as being related to the presence of numerous hearths. A high density of lithics yield from this layer, of which 23% were backed points (Lévêque & Miskovsky, 1983, p. 373). It is not divided into sub-layers. Lévêque considered this layer as representing the "classic" Châtelperronian complex (Lévêque & Miskovsky, 1983, p. 373)

### **Ensemble Marron (Em)**

Powdery in appearance and sometimes very flaky this sandy-clay layer is darker of colour compared to layer Ej. At its base it is more yellow, with the colour passing successively to brown and orange. It has been sub-divided into three sub-layers. The most underlying sub-layer Em-j, consists of brownish-yellow clay with a low quantity of limestone clasts compared to the other sub-layers. On top of Em-j is Em-f, which is reddish of colour and has been interpreted as holding evidence of charcoal and hearths. The top sub-layer is Em-o, which has a brown-orange colour and limestone clasts of differing sizes.

### **Ensemble Jaune (Ej)**

This yellow sandy-clay layer, which appears as orange sometimes, has the presence of an abundance of limestone clasts. About 30%-40% of these have a diameter between 5 and 10 cm. The top of this deposition was located just underneath the large limestone slabs, covering the deposit. Lévêque sub-divided layer Ej into two sub-layers. A top one (Ej-o) and a bottom one (Ej-m). Layer Ej-m has a fairly high percentage of thin, frost-prone plates which are quite corroded. Layer Ej-o is more pale yellow of colour and also shows signs of influence of cold temperatures, according to observations by Lévêque (1983, p. 375). Lévêque notes on the fact that the artefacts in this layer have undergone 'degradation', with a low number of backed points found here. He considers this layer as representing a regressive type of the Châtelperronian industry.

### 3.3 Studied material

The Châtelperronian points used in the analysis of this thesis all yield from the old excavations fulfilled by Lévêque during 1968 to 1990. All points were found in layers En, Em or Ej, which are also considered the *true* Châtelperronian layers. Of these artefacts 97 yield from layer En, 35 from layer Em and 16 from layer Ej. A selection of only CP points was chosen, and not any other tool type, because these can be attributed to the industry with certainty and thus give insight into whether there has been a sequential CP occupation at the site or not. By only looking at CP points and their damage it will become clear whether the separate layers have been the victim of admixture, or whether they show much similarities and were actually deposited at the same moment in time. SAG1 is located at the front of the cave, almost directly on the left side (Fig. 6)

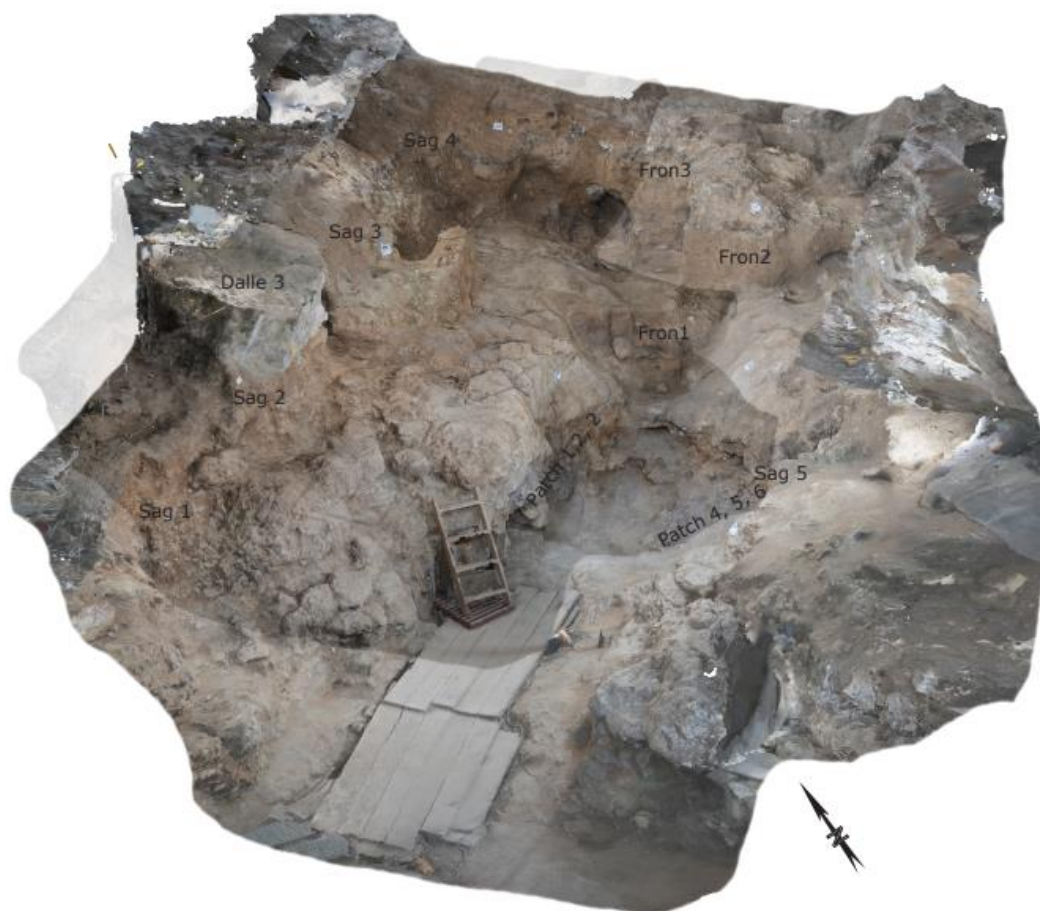

Figure 6. The different sections of Quinçay with the entrance on the 'bottom' before the planks, SAG1 in bottom left corner (Soressi et al., 2023, p. 31).

Lévêque's layers have been re-interpreted during recent excavations (Fig. 7, Fig. 8). SAG1 has also been micromorphologically sampled, which gives important insights into the composition of the sediment making up the layers, and which processes are altering them. Layers 5 to 2 all have

characteristics related to frost action: vertically oriented limestone clasts and sediment structure related to freezing action.

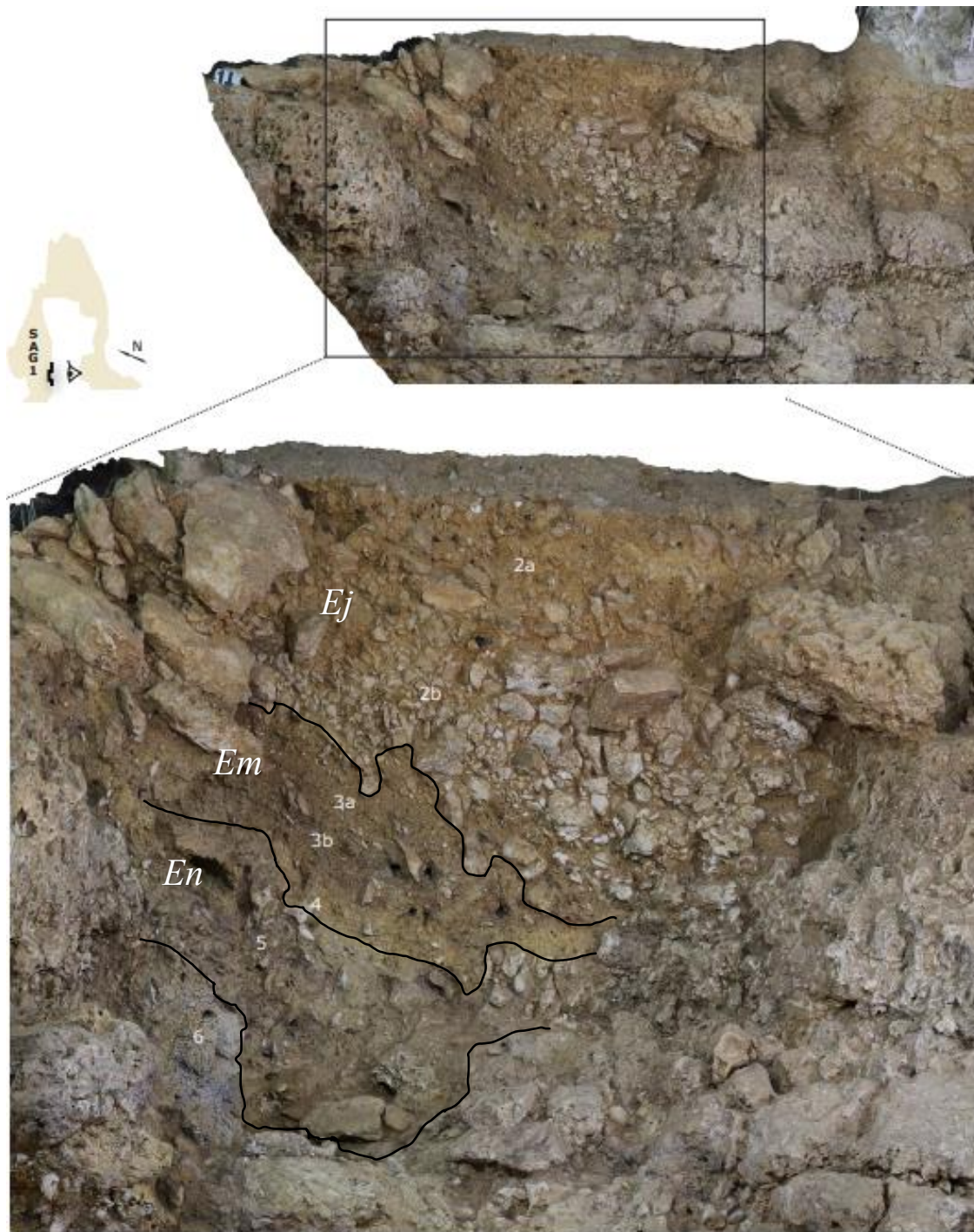

Figure 7. Section SAG1 with recently interpreted layers and how they correspond to Lévêque's layers. Layer En corresponds to layer 5, layer Em corresponds to layers 4, 3b and 3a and layer Ej corresponds to layers 2b and 2a. Modified from Soressi et al. (2023, p. 40)

## 4. Methodology

The goal for this analysis, as abovementioned, is to clarify whether the CP points found in the three overlying stratigraphic layers are in situ, or whether they might actually have been victim to post-depositional processes in the soil which caused them to move from their original spot of deposition. In order to get the answer to this question the degree of edge damage present on the points found in section SAG1 will be quantified. The different types and the degrees of specific edge damage found on the artefacts are described and compared (Villa & Soressi, 2000, p. 202) and edge angle analysis will be performed (McPherron et al., 2014, pp. 70-82; Dibble & Bernard, 1980, pp. 860-861). The former will aid in making classifications for the different types of edge damage that can be found in a single assemblage and the latter will illuminate the ways in which the angle of the edge can either promote or decrease the level of damage on a lithic artefact. In the research a macroscopic method is employed in which the scars that are visible to the naked eye are measured. In doing so arbitrary classes are constructed which will be explained below. These arbitrary classes are significant because it will clarify to any reader what is described, aiming for consistent observations that others would also make. This way a database is created aiming for a basis on objective observations. The limitations are in the sample size, which is not fully representative of the entire collection. A part of the excavated CP points reside in a depot in Liège.

### 4.1 Basic artefact description

While constructing the database all artefacts received their own arbitrary number in order to find specific artefacts more easily. In this section of the database the artefacts' unique ID is documented, as well as coordinates when available.

At Quinçay the lithic assemblage is represented for 80% by two raw materials: Bajocian/Bathonian gray flint and tertiary orange jasper (Roussel et al., 2016, p. 16) (Fig. 9). Both of these materials can be found in very close vicinity to the site. The artefacts produced using other, non-local, raw material can be traced back to the river valley beds of the Upper Turonian ca. 10-50 km northeast of the site (Roussel et al., 2016, p. 16). Since the gray flint and orange jasper are the most common material used, and show the highest levels of representation in the assemblage, the option for the raw material is one of the two, or simply the option 'other'. Under the class of 'other' we also see (heavily) patinated examples of lithics that could originally have been attributed to either the gray flint or orange jasper.

For all the artefacts, the fragmentation and dimensions are documented. Complete CP points can vary in length, but all show a clear backed side with a retouched proximal end (Roussel et al., 2016, p. 17). A complete CP point has a bulb of percussion or reworked platform and a complete distal tip, which is often quite thin. The proximal ends can be recognised by the reworked platform and general

roundness, whereas the distal tip is usually quite pointed and thin/fragile. Fragmentation type also records the artefacts as mesio-proximal when just a distal tip is missing. Length was measured on all artefacts, not just the complete ones. Whenever the artefact is complete it is measured from the platform to the distal end, in other cases it is measured by the maximum length. All of the measurements are taken using an electronic calliper, recorded in millimetres accurate to two decimals.

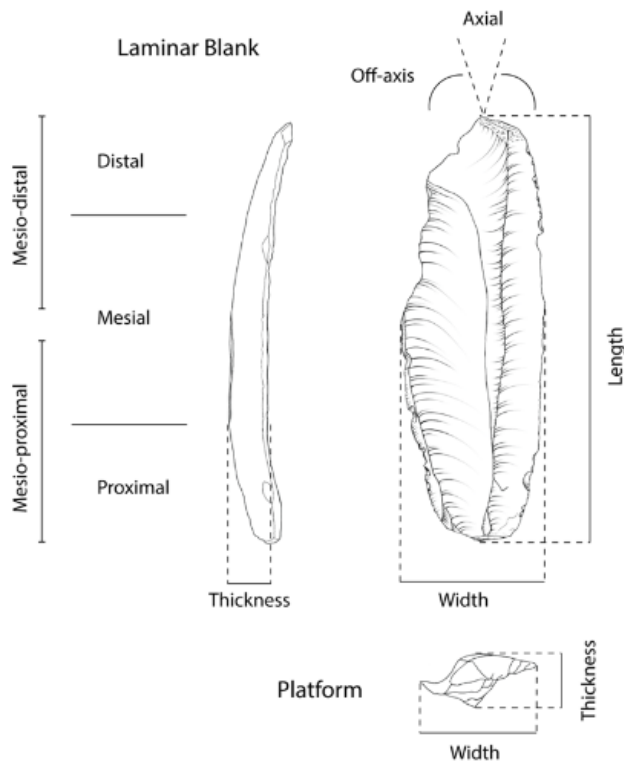

Figure 9. Recording protocol for fragmentation, size and orientation after Djakovic (2021, p. 47)

#### 4.2 Degrees of edge damage

Edge damage can be classified as scars and fractures on the outer ridges of a lithic artefacts which are generally smaller than 5 mm in maximum dimension (McBrearty et al., 1998, p. 114). All of the edge damage that is quantified is based on one of the lateral edges that was considered (part of) the cutting edge. All documentations yield from the same lateral side, which is the edge of the point that has not been modified by abrupt retouch. Besides the edge, also the degree of rounding present on the dorsal face of the CP points is described.

##### *Type of edge damage*

A good way to get a grip on the level of disturbance present in an assemblage is to document the type and degree of edge damages. This attribute focuses on measuring the presence and frequency of specific scars. They are classified based on macroscopic edge damage observable with the naked eye. Classes have been modified from Villa & Soressi (2000, p. 202).

The classifications distinguishes between marginal (scars between 1.0 and 1.5 mm in depth with bulbar scar), medium (scars between 1.5 and 4.5 mm in depth with bulbar scar), microfractures (small breakages of the edge without presence of bulbar scar up to 1.0 mm in depth) and invasive (breakages of the edge without presence of bulbar scar larger than 1.0 mm in depth). Only one of the abovementioned classifications is attributed to an artefact. This is decided based on the type of edge damage that is the most prevalent on one specific point. In this way it is noted which type of edge damages are the most common in a specific layer, and throughout the entire assemblage. Different types of taphonomic processes lead to different types of edge damage and therefore it is of significant importance to create this quantification to see which types of edge damage are represented.

#### *Position of taphonomic removals*

In this attribute it is documented whether the most amount of damage is represented on either the ventral or dorsal face of the artefact. Whenever an artefact is damaged on both faces, an option for 'both' becomes available. In recording this attribute it will become clear from which face the force originated from that caused the damage.

#### *Number of taphonomic removals*

When documenting the number of taphonomic removals all the different types of edge damages present are counted that had a depth measuring of at least 1.0 mm. The categorisations consist of 0, 1-2, 3-5, 6-10, 11-20 and 20+. These categories best represent the level of edge damage and amount of different fractures. It is important to note that when describing the number of taphonomic removals only the removals that measure at least 1.0 millimetre are counted. This means that when an artefact's damage is mainly represented by microfractures they will not be considered in the number of taphonomic removals.

#### *Size of largest removal*

To measure the size of the largest removal a digital calliper is used. Measured removals are rounded to a single decimal. This attribute relates to the type of edge damage and gives further insight into the severity of the damage. It can be hard to interpret whether the edge has an invasive break or whether a scar follows the intended shape of the lithic artefact, because of this I measure the maximum depth of a single scar in relation to the edge. All measurements have been rounded up to their nearest whole number or .5 decimal of that number.

#### *Rounding*

When documenting the rounding present on the lithic artefact, only the dorsal face of the point is taken into consideration. What is described is process of rounding an artefact has been subjected



during taphonomic processes. There are three classes: fresh, moderately abraded and abraded. The rounding tells whether the artefact was subjected to rolling motion (Bustoz-Pérez et al., 2019, p. 12)

#### *Percentage of lateral edge affected*

As mentioned above, the edge damage that gets described is all represented on the lateral edge of the point, which is the side on the opposite end of the side modified by abrupt retouch. The percentage of the lateral edge affected measures how much of this lateral side is relatively affected. These classes consist of 0%, 1%-20%, 21%-40%, 41%-60%, 61%-80%, 81%-99% and 100%. This will clarify the level of invasiveness present on a single point.

### **4.3 Edge angle analysis**

It has been determined that the angle of the edge has significant influence on the amount of edge damage present on a singular lithic artefact. Smaller edge angles show a larger amount of damage compared to larger edge angles (McPherron et al., 2014, p. 78). Thus it is important to measure the edge angle of all lithic artefacts present in my assemblage. To do this the method proposed as most reliable by Dibble and Bernard (1980, p. 860) is employed, which is measuring the edge angle with a calliper. Before measuring it is necessary to attach a vertical bar just behind the needle points of the calliper. This fixed point needs to be placed very precisely. For this research I chose to attach the vertical bar at 2 mm distance from the end of the needle points. It is against this vertical bar that the point of the edge angle will rest while the needle points hold on to the sides, creating a triangular shape. In this way the method allows the measurement of the thickness of the edge with a known fixed point. With the thickness measure and the known constant value from the vertical bar to the end of the needlepoints the edge angle can be calculated of this specific angle using a trigonometric equation (Fig. 10), in which  $\theta$  is the edge angle, D is the constant value (in my case 2 mm) and T is the measurement taken with the calliper (Dibble & Bernard, 1980, p. 861). I chose to take the mean of four edge angle measurements per lithic artefact: one at the most distal end, one at the most proximal end and two in the middle. Edge angle analysis is tricky, and it would be best to have the edge angle calculated by multiple individuals to ensure that your data is right. For this reason it was chosen to take four separate measurements, instead of just two.

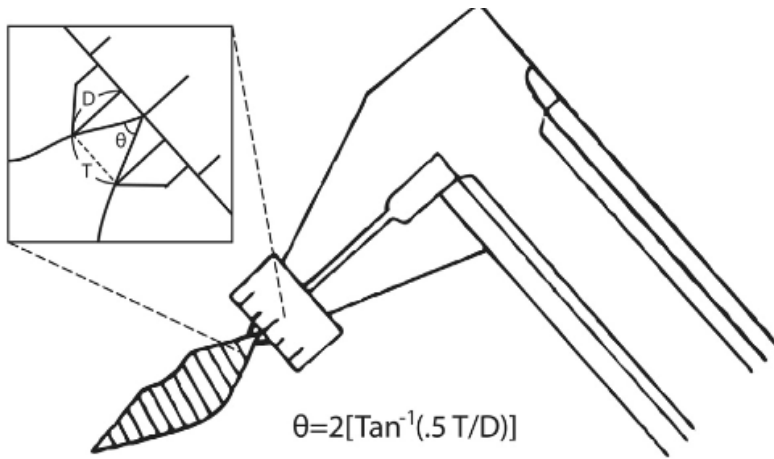

Figure 10. The calliper method (McPherron et al., 2014, p. 73, after Dibble and Bernard, 1980)

Furthermore, the degrees of the steepest affected angle are documented in a more generalised classification: 0-30, 30-60 and 60-90 degrees. This is because the steepest affected angle can differ from the mean taken from the four measurements for the edge angle and plays a crucial in finding the correlations between the level of edge damage compared to the degree of the angle, especially considering the steeper an edge is, the more prone to damage it becomes. Considering that the artefacts yield from three different layers I am expecting to find some clear differences between them. In the next chapter the results will be presented based on the observations and documentations made.

## 5. Results

In this chapter the results will be presented based on the attributes recorded in the database. The sample consists of 148 Châtelperronian points, of which 97 have yielded from layer En, 35 from layer Em and 16 from layer Ej. The goal is to find the similarities and differences between the degree and types of edge damage between the three layers. To achieve this, the layers will be analysed and compared with each other, in this any subsequent trends that have appeared will be explained so that it can become obvious whether there are interesting patterns visible throughout the different layers and how they are connected and influenced by any internal and external forces. It is important to keep in mind when interpreting the data that there is much more data available for layer En compared to layer Em and Ej.

### 5.1 Measurements

The length, width and thickness of all the artefacts have been analysed using box plots with whiskers to show the distributions of the mean, the outliers and the means of the most important values. This way there is a clear understanding of how these attributes compare to each other in the three layers and how they are similar or different to each other.

Layer En distinguishes itself by having multiple outliers throughout the documentation of the length, width and thickness. The N=23 complete pieces found in layer En can differ quite a lot from each other, with the longest point being over 8 cm and the shortest around 2,5 cm, with a distance of ca. 5,5 cm. Considering the length of the complete pieces of layer Em it is interesting to see that the first and fourth quartiles are not very far removed from each other, meaning the complete pieces are more consistent than those found in layer En. The average length found in the complete pieces in layer En is ca. 5,4 cm, with a standard deviation of 1,3 cm, compared to the average length of artefacts from layer Em at 6,0 cm and a standard deviation of 1 cm it becomes obvious that the artefacts found in layer Em are slightly larger in length. The complete pieces of layer Ej are close together in length (ca. 5 cm), but quite a bit shorter compared to the complete pieces from layers En and Em.

In general the fragmented pieces show a greater variety in size, which is logical considering all different types of fragmentations get grouped together. Nevertheless, the fragmented pieces in layer En show the highest variety compared to layer Em and layer Ej. The longest fragmented piece is ca. 10 cm, and the shortest around 1,5 cm, which can both be found in layer En. However, there does not seem to be much difference between the length of fragmentation between layer En and layer Em, with

the average length of layer En at 4,7 cm with a standard deviation of 1,5 cm and an average length of 4,2 cm with a standard deviation of 1,3 for layer Em. Moving to layer Ej the interquartile distance is the largest of all layers at ca. 2,4 cm. The average length of artefacts found in layer Ej is ca. 3,4 cm, with a standard deviation of 1,2 cm. In comparing the layers it becomes clear that layers En and Em have a higher variety in size, and artefacts with a higher length, whereas layer Ej has more consistent pieces, that are shorter in length.

The width of the complete pieces of layer En are quite close to one another in numbers, with a single outlier sporting the highest width: ca. 2,4 cm. The measurements of width in layer Em have a longer interquartile range, but a shorter distance from the first to the fourth quartile compared to layer En. Meaning the pieces found in layer Em have a higher width, and less outliers compared to layer En. The average width of complete pieces found in layer En is 1,6 cm and in layer Em 1,8 cm, both with a standard deviation of 0,2 cm. In the fragmented pieces one outlier is present in layer En: one artefact with a width of ca. 2,9 cm. Layer Em is again quite close in size to layer En. Their respective averages are both ca. 1,7 cm, where layer En shows a standard deviation of 0,3 cm and layer Em one of 0,4 cm. Layer Ej has the artefacts with the highest widths, also with the presence of one outlier which has a width of ca. 3,4 cm: the highest of all layers. The average width found in layer Ej is 1,9 cm with a standard deviation of 0,5 cm, meaning this layer has the largest variety in width sizes found compared to layers En and Em.

The thickness of the complete pieces in layer En have a larger distance between the different important values, compared to layer Em. The interquartile range is ca. 0,3 cm and the distance from the first to the fourth quartile is 0,7 cm. The average thickness found in this layer is 0,6 cm with a standard deviation of 0,2 cm. This is the only size attribute recorded for layer En where there is no outlier. Layer Em has an interquartile range of 0,1 cm, a distance between the first and fourth quartile of 0,3 cm and also an average of 0,6 cm, but with a standard deviation of 0,9 cm. The two complete pieces from layer Ej are a bit thicker compared to the averages for layers En and Em, at least one cm. In the fragmented pieces of layer En there are two outliers measuring at ca. 1,5 and 1,3 cm thickness. Here it is evident that all layers are quite similar regarding the median of thickness. The average for all layers regarding the thickness is ca. 0,6 cm with a standard deviation of ca. 0,2 cm, meaning that the thickness is very consistent throughout the entire assemblage present in the three layers.

Overall, the highest variety is found in the length of the artefacts throughout the three layers, which is logical since the length is the most fragile compared to the width and the thickness. In layer Ej the shortest artefacts are found, and in layer Em the longest are found. Furthermore, the width and thickness of the artefacts found throughout the three layers are all quite close to each other and thus support a consistent method in the manufacturing of Châtelperronian points. It is also interesting that

the only two complete pieces yielding from layer Ej are both quite thick and short. Thick angles are less likely to become damaged compared to thin and sharp angles.

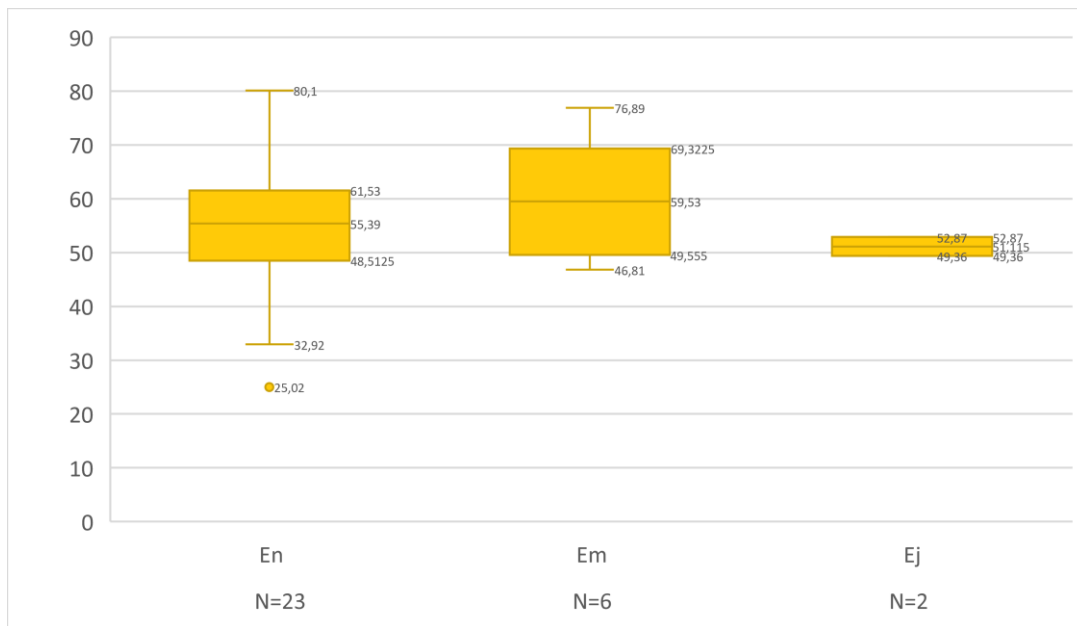

Figure 11. Length of the complete CP points in millimetres in the layers En Em and Ej

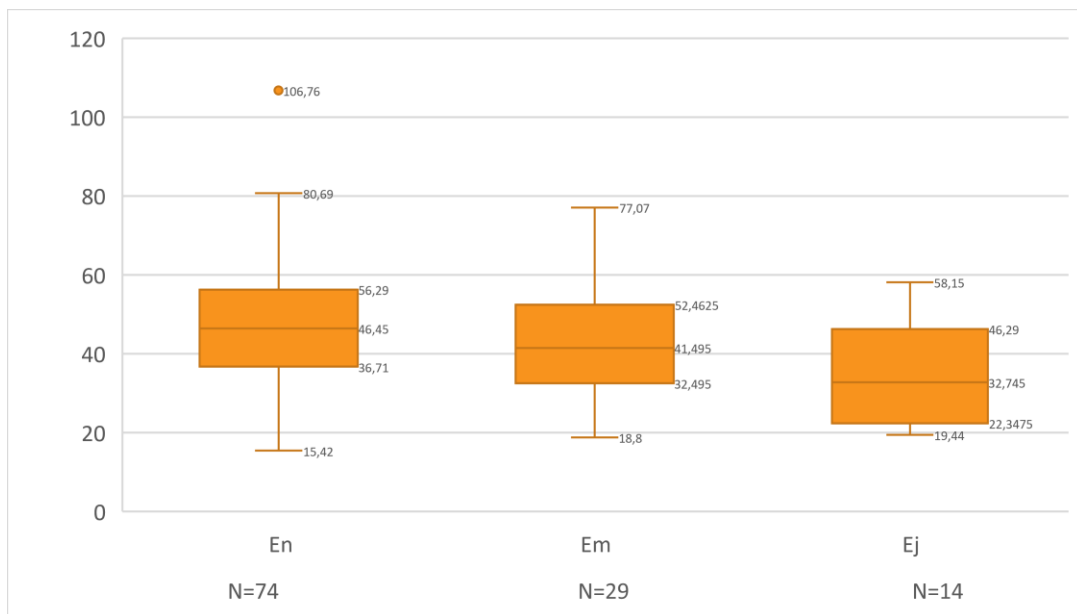

Figure 12. Length of the fragmented CP points in millimetres found in the layers En, Em and Ej

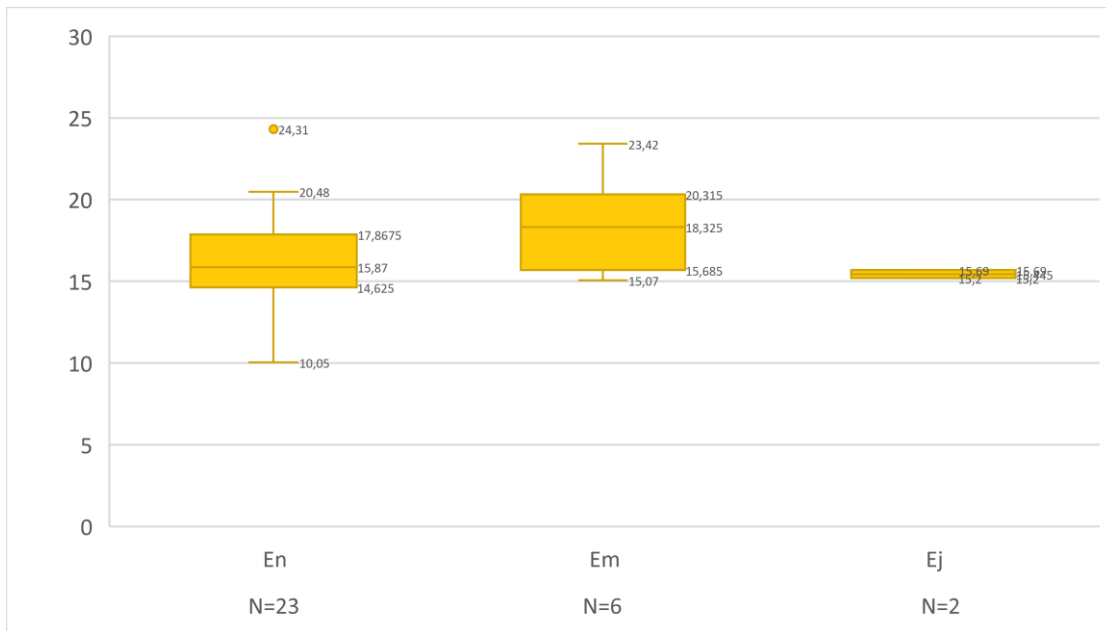

Figure 13. Width of the complete CP points in millimetres in the layers En, Em and Ej

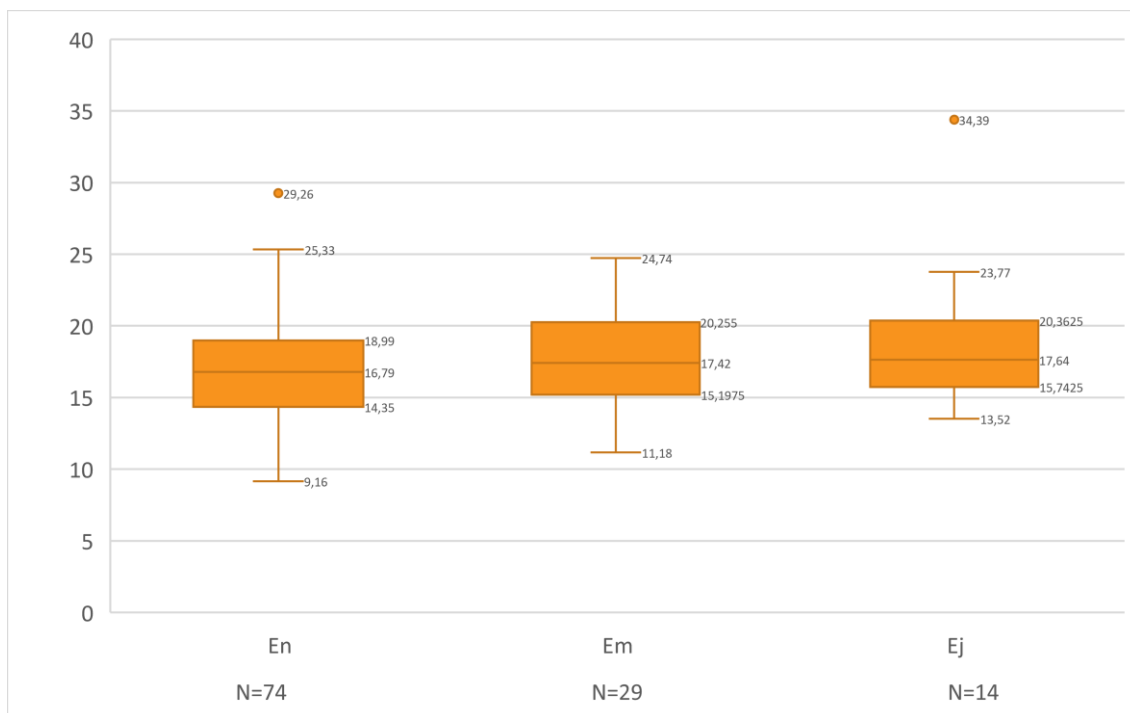

Figure 14. Width of the fragmented CP points in millimetres in the layers En, Em and Ej

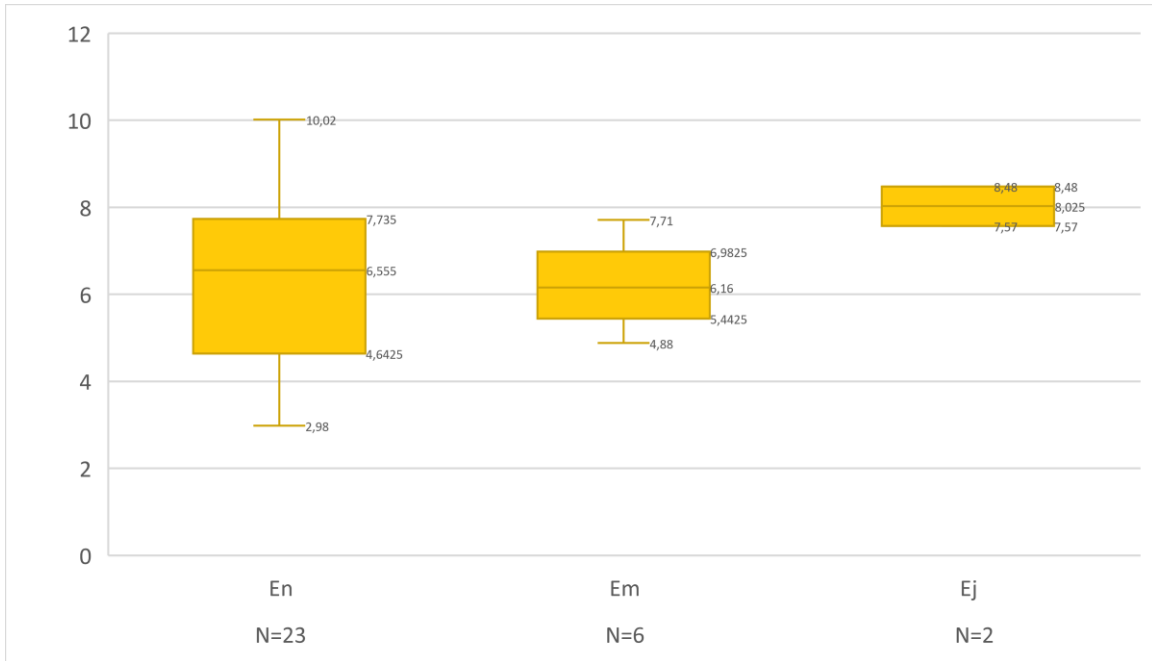

Figure 15. Thickness of the complete CP points in millimetres in the layers En, Em and Ej

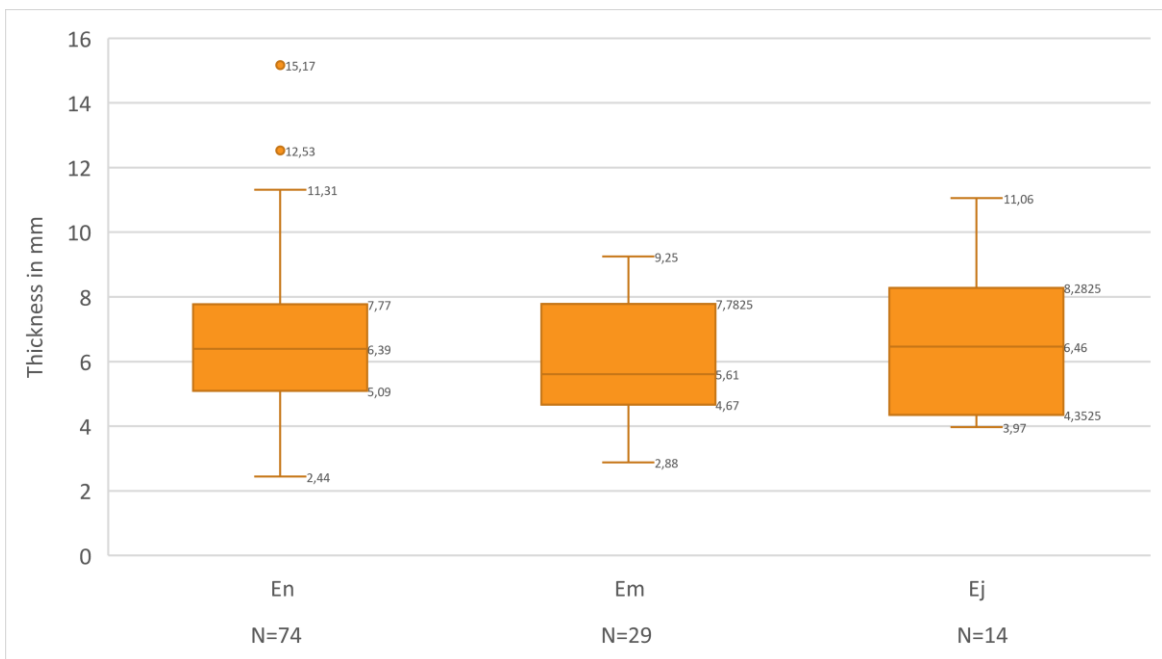

Figure 16. Width of the fragmented CP points in millimetres in the layers En, Em and Ej

## 5.2 Raw material

In total, and especially in layer En and layer Ej, the largest amount of the artefacts have been made from gray flint. This is interesting compared to layer Em where most of the artefacts are manufactured using ‘other’ raw material.

Count of raw material				
Row Labels	Grey Flint	Orange		Grand Total
		Jasper	Other	
Ej	7	6	3	16
Em	12	8	15	35
En	42	34	21	97
<b>Grand Total</b>	<b>61</b>	<b>48</b>	<b>39</b>	<b>148</b>

Table 1. Distribution of the different raw material of CP points found at Quinçay throughout layers En, Em and Ej

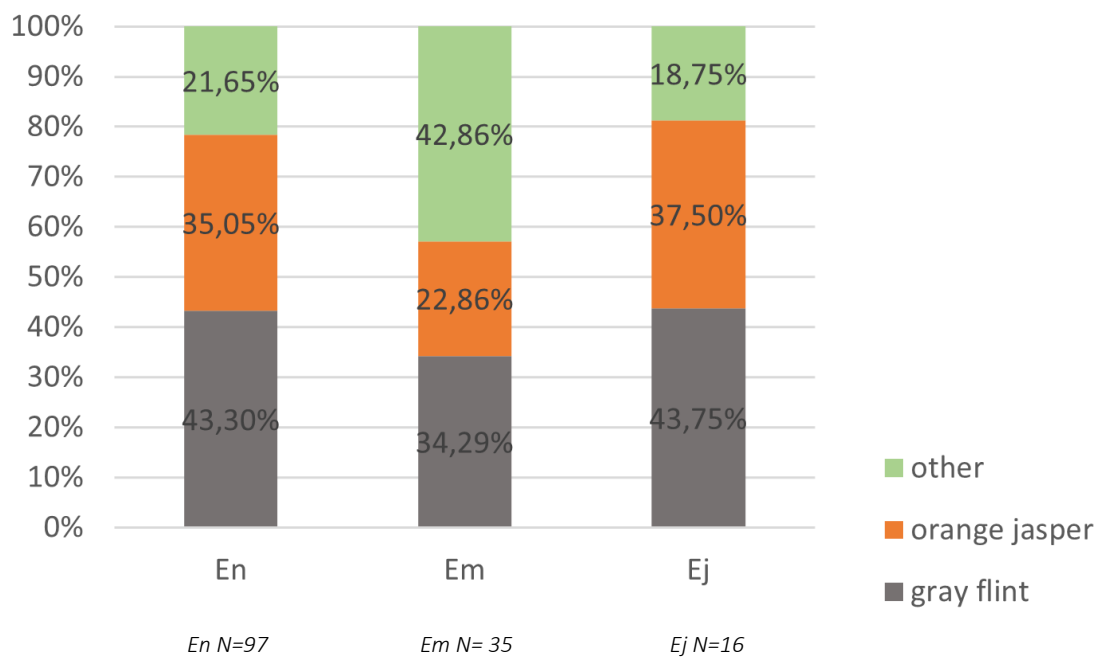

Figure 17. Distribution of the different raw material of CP points found at Quinçay throughout the layers En, Em and Ej in percentages



### 5.3 Fragment type

The percentage of complete artefacts throughout all three layers is 20,27%. Meaning the percentage of fragmented artefacts stands at 79,73%, of which most (26,35%) are mesio-proximal, followed by 20,27% mesial, 18,92% mesio-distal and 13,51% distal artefacts. Finally the lowest number of fragmentation is that of the proximal kind, of which only one was found (1,48%) in layer Ej. The most amount of complete CP points are found in layer En, the least in layer Ej. In layer En the highest percentage of an artefact found is that of the mesio-proximal fragmentation, which is also one of the fragmentation types mainly found in layer Ej. The other most found fragmentation type in layer Ej is the most distal part of an artefact, which is the most fragile part of a CP point since it is subsequently also the thinnest. In layer Em the parts that are mainly found are the mesial and mesio-distal fragments of the artefacts. A trend can be seen in which the amount of complete artefacts decreases from layer En to the overlying layers Em and Ej.

Count of fragment							
Row Labels	distal	mesio- distal	mesial	mesio- proximal	proximal	complete	Grand Total
Ej	5	1	2	5	1	2	16
Em	4	10	10	5		6	35
En	11	17	18	29		22	97
<b>Grand Total</b>	<b>20</b>	<b>28</b>	<b>30</b>	<b>39</b>	<b>1</b>	<b>30</b>	<b>148</b>

Table 2. Amount of fragmentation and complete CP points throughout the layers En, Em and Ej.

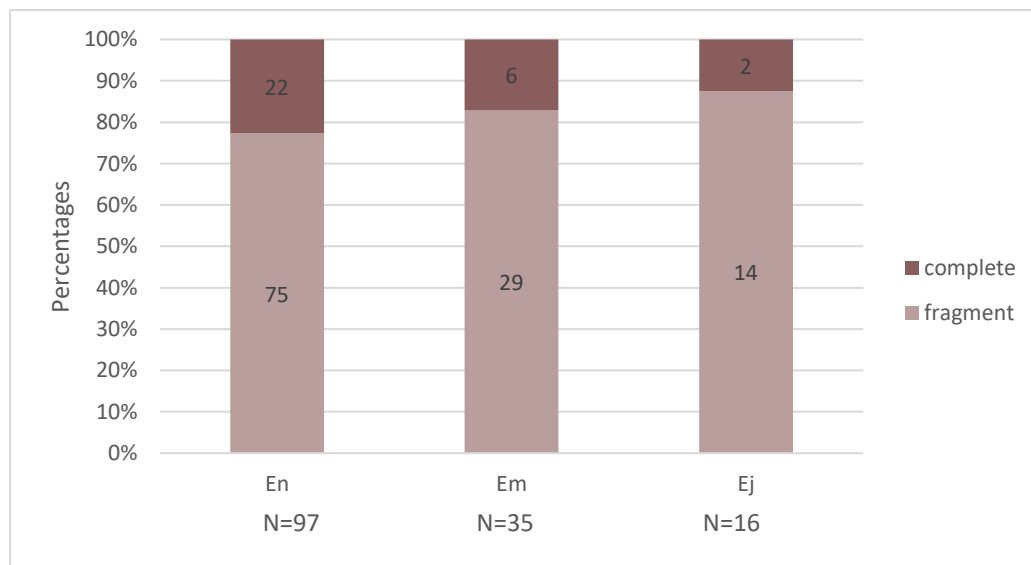

Figure 18. Amount of complete, in comparison to fragmented, CP points throughout layers En, Em and Ej.

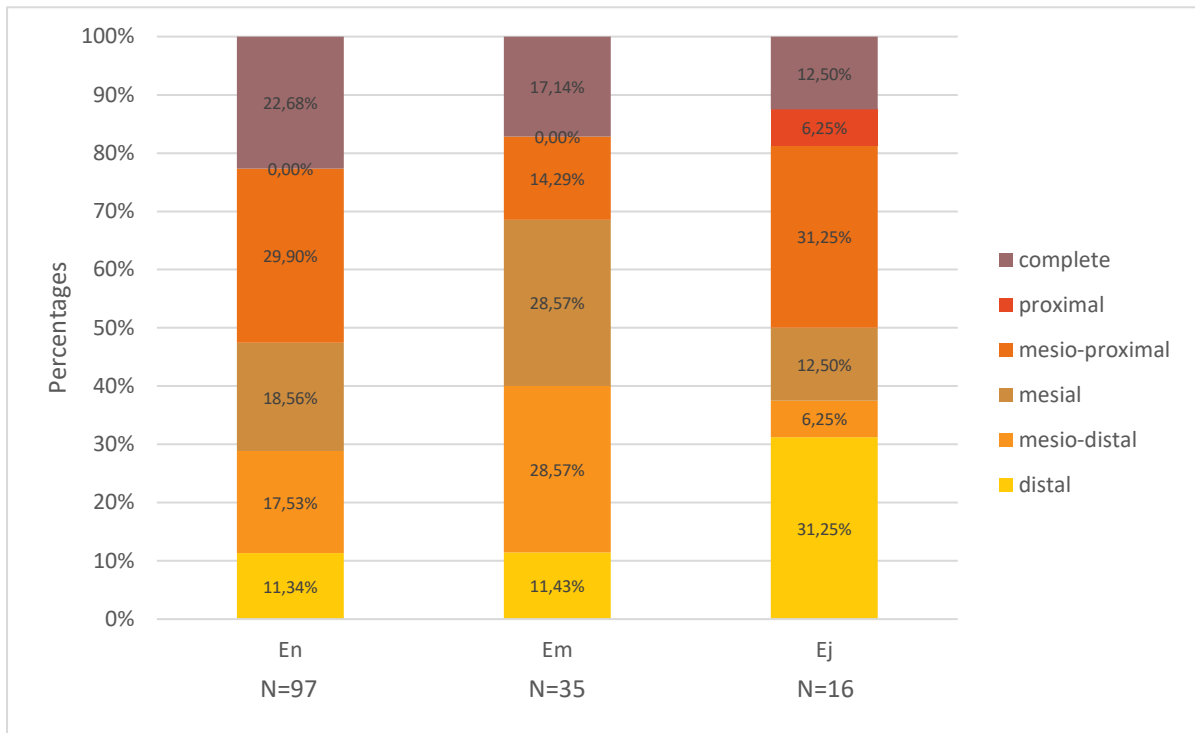

Figure 19. Amount of fragmented and complete CP points in percentage throughout layers En, Em and Ej.

## 5.4 Type of edge damage

When considering the results it is important to note that the ‘Marginal’ and ‘Microfracture’ damage types can be created with less external force on the artefacts than what is needed for the ‘Medium’ and ‘Invasive’ damage types

The ‘Marginal’ damage type is present on N=36 artefacts of the N=148 throughout the entire assemblage, and is, in comparison to the other layers, the most common in layer Em, where it takes up 31,43% of the layers’ assemblage. In none of the layers is it the most common type of edge damage, being the least represented in layer Ej. Secondly, the ‘Medium’ damage type is represented N=23 times, which is the absolute least compared to the other types of edge damage (See Table 3). However, it is the damage type that is second most common in layer Ej. The damage type of which the most is found throughout the three layers is that of the ‘Microfracture’ kind. N=59 pieces have been retrieved on which this type of damage has been found, of which the most in layer En and Em, in which the damage type represent more than 40% of the assemblage. In layer Ej it is one of the least found types. Finally, the ‘Invasive’ edge damage type. There are N=30 artefacts damaged by this type and is the most found in layer Ej, where it represents 43,60% of the assemblage. Interestingly, it is the damage type which is the least found in layer Em, even though it is represented for 22,68% in the assemblage of the underlying layer.

In layer En the assemblage is represented for 43,60% by artefacts with the ‘Microfracture’ damage type. The second most common type is the ‘Marginal’ damage type, represented for 23,71%, which is very close to the ‘Invasive’ damage type which is present for 22,68% in the assemblage. The least common type is that of the ‘Medium’ damage, which only occurs for 10,31%. It is interesting, and unexpected to see that the ‘Invasive’ type is quite common in this layer, as there was a trend expected related to an increase in the invasiveness of damage when moving from layer En to Ej. Of the assemblage yielding from layer Em 42,86% is represented by the ‘Microfracture’ damage type, subsequently also being the damage type the most found in this layer. Secondly, similar to layer En, the second most found damage type is that of the ‘Marginal’ type at 31,43%, followed by the ‘Medium’ damage type at 22,68%. Far out the least number of edge damage found in this layer, as well as in any layer, is that of the ‘Invasive’ type, of which only 2,68% is represented in layer Em. Finally, layer Ej its most common types of edge damage are quite different compared to layers En and Em. The two types of damage that are the least common in those two layers, are actually the ones that are most found in layer Ej. The most common edge damage found in this assemblage is the ‘Invasive’ type at 43,75%, followed by the ‘Medium’ type at 31,25%. The ‘Marginal’ and ‘Microfracture’ damages are both represented by 12,50% in this layer

Multiple important things becomes obvious by these numbers. There is a peak of the ‘Marginal’ damage type present in layer Em, although this is one of the least represented types of damage in layer Ej. On the other hand, the ‘Invasive’ damage type peaks in layer Ej while this is the least represented in layer Em. The ‘Medium’ type increases steadily by ca. 10% moving from layer En to Em, and again when moving from layer Em to Ej. When considering the ‘Microfracture’ damage type however a sudden drop in percentages becomes clear when moving from layer En and Em to layer Ej.

<b>Count of type of edge damage</b>					
<b>Row Labels</b>	<b>Marginal</b>	<b>Medium</b>	<b>Microfractures</b>	<b>Invasive</b>	<b>Grand Total</b>
Ej	2	5	2	7	16
Em	11	8	15	1	35
En	23	10	42	22	97
<b>Grand Total</b>	<b>36</b>	<b>23</b>	<b>59</b>	<b>30</b>	<b>148</b>

*Table 3. Distribution of the types of damage present on CP points in layers En, Em and Ej*

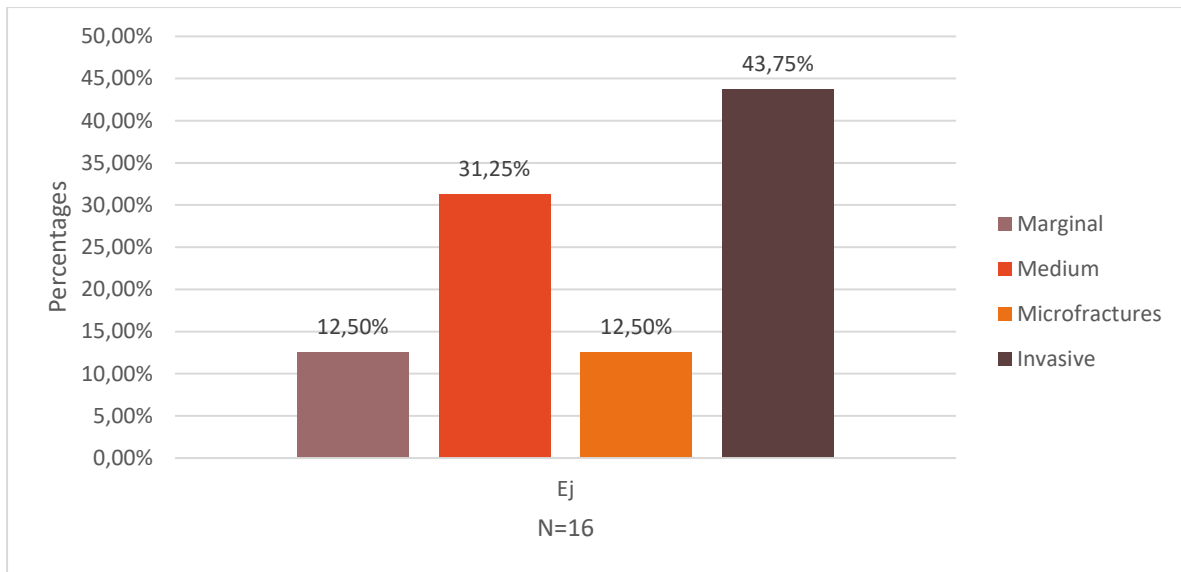

Figure 20. Percentage of the types of damage present on CP points in layer Ej

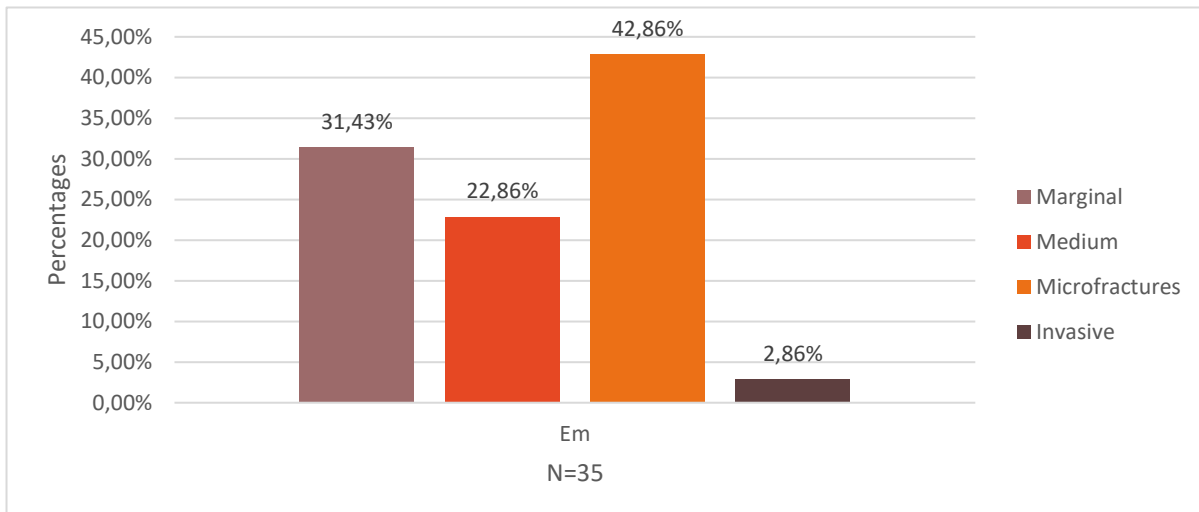

Figure 21. Percentage of the types of damage present on CP points in layer Em

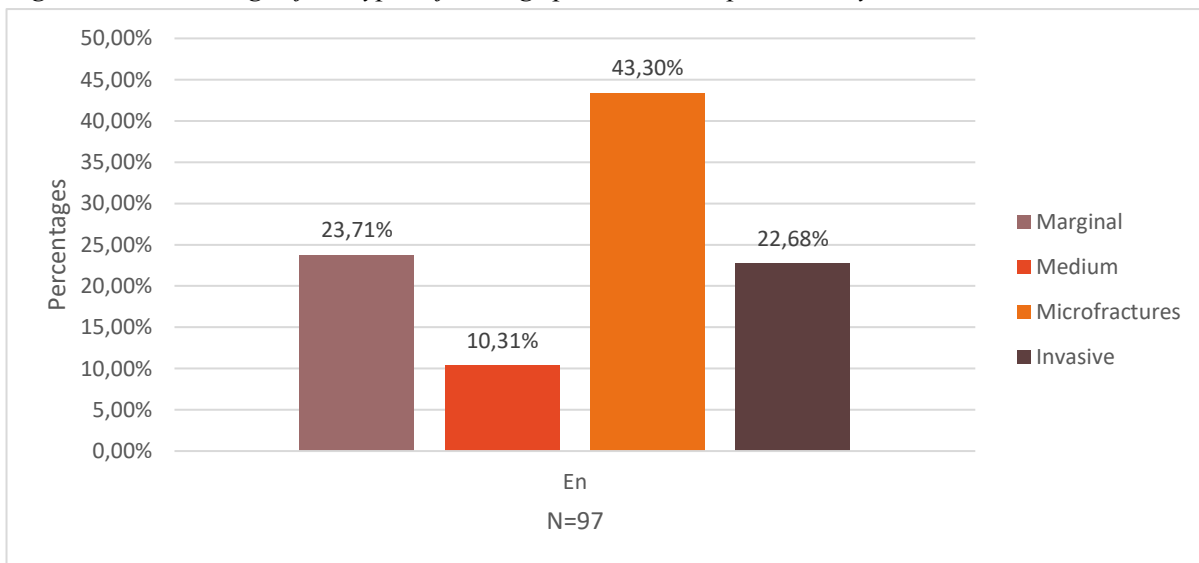

Figure 22. Percentage of the types of damage present on CP points in layer En

### 5.5 Position of taphonomic removals

All layers are represented most by artefacts that show damage on both their faces. Especially layer Ej has artefacts mainly affected by forces coming from multiple sides. Besides this, layers En and Em are very similar considering the percentages of which faces of the artefact were affected most by damage, with layer Em only having a bit higher representation. The ventral face of an artefact is the second most affected In layers En and Em, with both of their percentages being around 29%, closely followed by the dorsal face of an artefact, which damaged face is represented by at least 20%. However in layer Ej the ventral face is actually the face that is the least affected by damage, at only 6,25%, and the dorsal face is damaged a lot more often: 31,25%. In this case we can see an increase from layer En to layer Ej in the amount of artefacts found damaged on both sides and on the dorsal side. However, there is also a decrease in the amount of artefacts suffering damage on just the ventral side

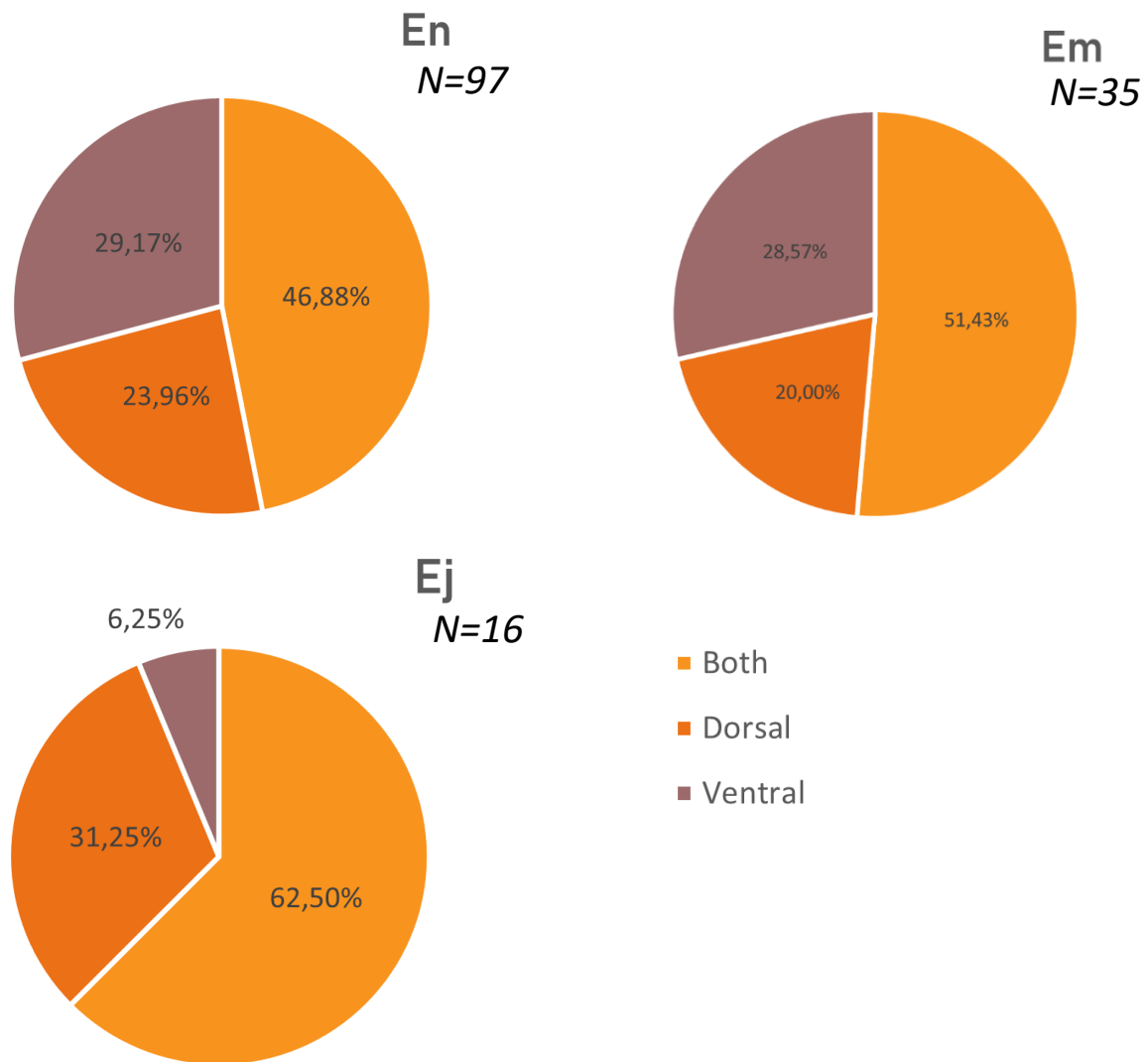

Figure 23. Percentage of affected face of CP points in layers En, Em and Ej

## 5.6 Number of taphonomic removals

The number of taphonomic removals varies between the three layers. There is a low number of artefacts with 0 removals throughout all layers. The 1-2 amount of removals are the greatest in layer En, and the least in layer Em, whereas the 3-5 amount of removals are the most common in layer Em. Layer Ej has the highest amount of taphonomic removals represented in their assemblage with 68,75% of artefacts having 6, or more than 6 removals. Lastly, considering the 11-20 removals and the 20+ removals we see the lowest amount of these represented in layer En, followed by layer Em and finally layer Ej, which has the most. When looking at the generalised classes in Fig. ... there is a clear trend visible in which there is a decrease in the amount of artefacts having 0 to 5 removals, and an increase in the amount of artefacts with 6 to 20+ removals moving from layer En to the overlying layers, with the highest number of removals present in layer Ej.

Taphonomic removals							
Row Labels	0	1-2	3-5	6-10	11-20	20+	Grand Total
Ej		2	3	6	4	1	16
Em	1	1	14	12	5	2	35
En	5	29	37	14	12		97
<b>Grand Total</b>	<b>6</b>	<b>32</b>	<b>54</b>	<b>32</b>	<b>21</b>	<b>3</b>	<b>148</b>

Table 3. The number of taphonomic removals on CP points throughout layers En, Em and Ej.

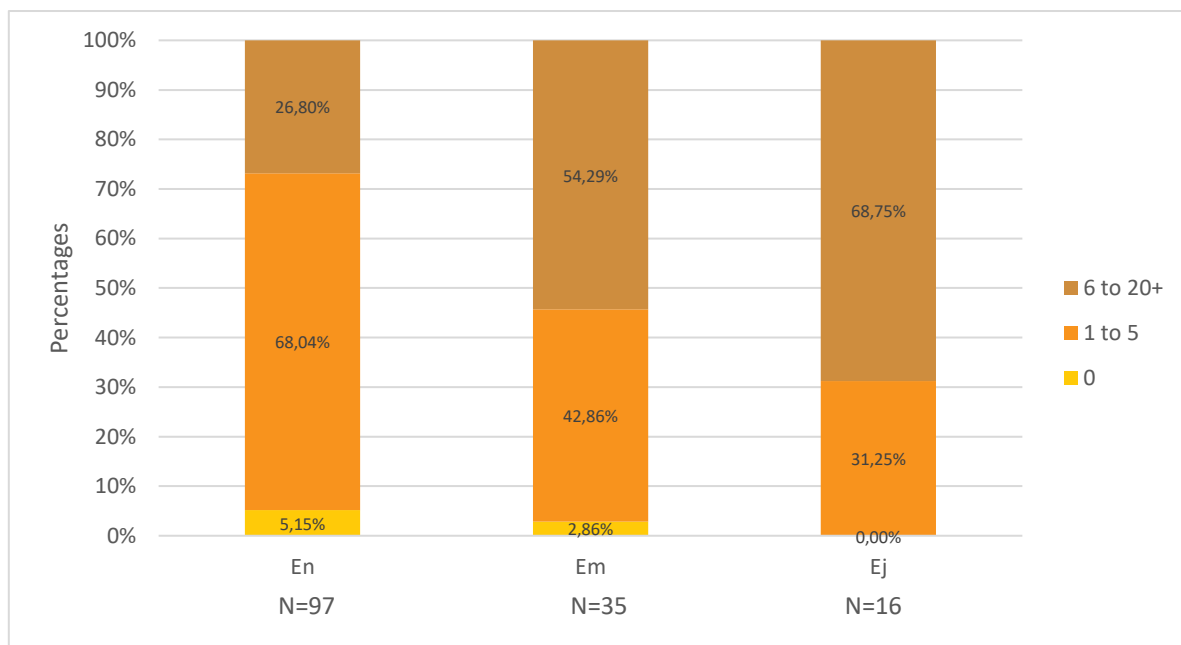

Figure 24. Amount of removals on CP points in generalised classes in percentages per layers En, Em and Ej.

## 5.7 Size of largest removal

Only layer En has the presence of artefacts of which the size of their largest removal is the size of 0 to 1 mm. Even in this layer it is not very common. The amount of artefacts affected by a removal the size of 1-2 mm is the most common however throughout all three layers. In layers En and Em it is far out the largest measured removal throughout the assemblages. In layer Ej the 1-2 mm largest removals are found in same frequency as the size of 2-3 mm for the largest removal. The 2-3 mm largest removal are also the second most common size found in layer En and Em. The 3-4 mm is the third most common largest removal size found in layer En, which differs from the other two layers, in which the 4-5 mm size of largest removal is the third most common. Finally, there is an overall low number of size of largest removal larger than 5 mm.

There is quite some variation in the size of the largest removal in layers En, Em and Ej. Besides this, the artefacts present in layer En and layer Em are mainly damaged by removals the size of 1 mm. The artefacts in layer Ej most commonly suffer from removals the size of 2 mm, after this removals the size of 4,5 mm. Layers En and Em have a higher frequency on the ‘low’ side of removals, whereas layer Ej has a higher frequency on the ‘high’ side of removals. For layer En the average stands at 1,8 mm with a standard deviation of 1 mm. In layer Em this number is higher: the average size of largest removal found in this layer is ca. 2 mm, with a standard deviation of 1,4 mm. Again the number increases when moving to layer Ej, here the average size of largest removal stands at 2,3 mm, with a standard deviation of 1,2 mm. The average size of the largest removal for all N=148 pieces in the assemblage is 1,90 mm, with a standard deviation of 1,19 mm. A trend become obvious in which there is an increase in the size of the largest removal moving from layer En to the overlying layers.

Size of largest removal in mm	Column Labels							
	until 1	1 to 2	2 to 3	3 to 4	4 to 5	5 to 6	6 +	Grand Total
Ej		6	6	1	2	1		16
Em		21	6	2	3	2	1	35
En	9	45	22	17	2	1	1	97
<b>Grand Total</b>	<b>9</b>	<b>72</b>	<b>34</b>	<b>20</b>	<b>7</b>	<b>4</b>	<b>2</b>	<b>148</b>

Table 4. Amount of removals on CP points and their sizes in millimetres throughout layers En, Em and Ej



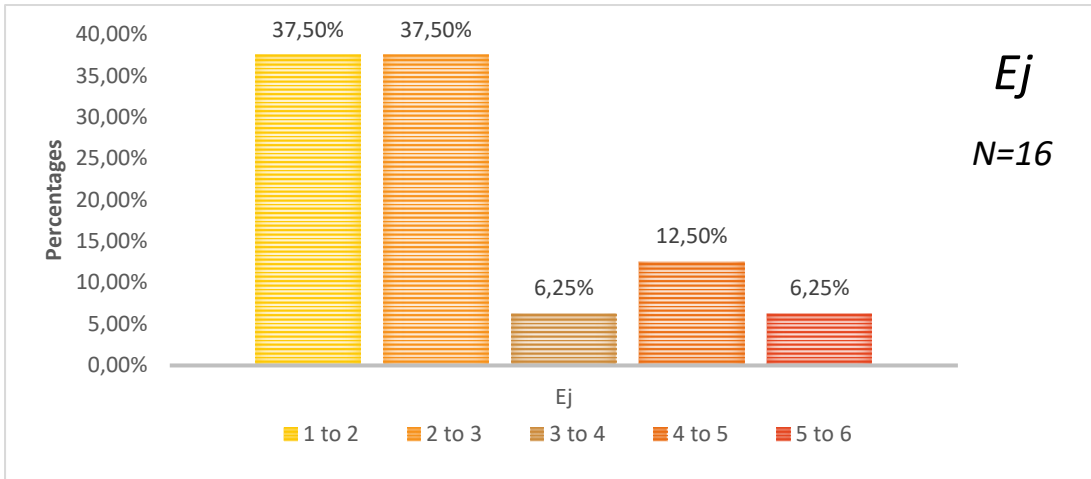

Figure 25. Percentage of size of largest removal on CP points found in millimetres

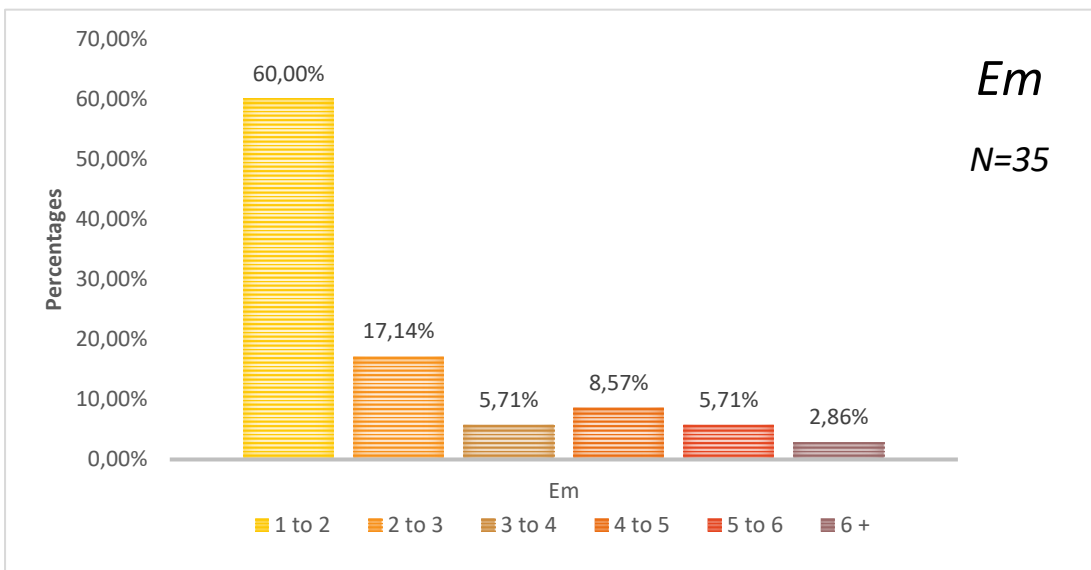

Figure 26. Percentage of size of largest removal on CP points found in millimetres

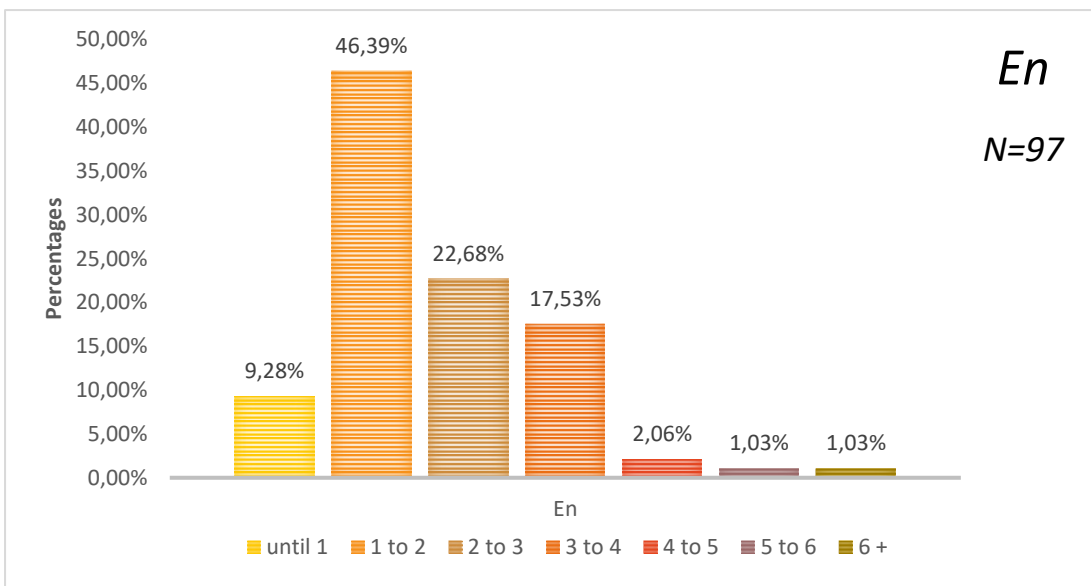

Figure 27. Percentage of size of largest removal on CP points found in millimetres

## 5.8 Rounding

The degree of rounding of the dorsal face of a singular artefact gives information on whether the artefact had been subjected to a rolling motion. When analysing the artefacts it became apparent that almost all artefacts, however laterally damaged, did not have any sort of abrasion on their dorsal face. The only examples of moderately abraded artefacts were discovered in layer Ej, of which none heavily abraded.

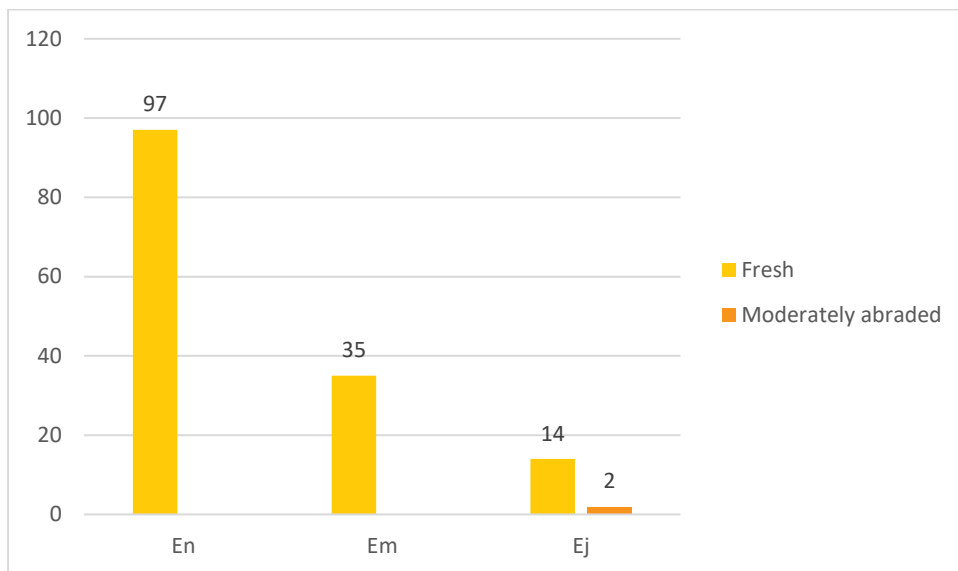

Figure 28. Degree of rounding present on the CP points in layers En, Em and Ej

## 5.9 Percentage of lateral edge affected

In all layers the highest relative percentage of the artefacts' lateral edges were for 80 to 100% affected by post-depositional processes. This means that most of the artefacts throughout the three layers (N=61) show some sort of damage on their outer ridge, larger than 0,5 mm, that is not part of the original cutting edge or retouch. Layer En has the widest variety in percentage of lateral edge affected, almost 50% of the artefacts have a lateral edge that is affected for 80 to 100%, followed by a 40% to 80% lateral edge affected. Layer En is the only layer with the presence of artefacts that are affected for less than 40%, represented by 19,79% artefacts of the assemblage. In layer Em the variety in percentage of the lateral edge affected starts to be more skewed toward the higher percentages, with no artefacts showing damage on only less than 40% of their lateral edge. The artefacts in layer Ej are mainly affected for 80 to 100% or, less commonly, 61% to 80%. In layer Em the variety in percentage of the lateral edge affected is skewed toward the higher percentages, with no artefacts showing damage on only <40% of their lateral edge. Considering figure 29 a trend becomes obvious in the percentage of the lateral edges affected. There is an increase in the amount of artefacts affected for 80% to 100% from layer En to layer Ej. As well as, subsequently, a decrease in the artefacts affected for less than 40% to 80%.

Percentage of lateral edge affected							
Layers	1% - 20%	21% - 40%	41% - 60%	61% - 80%	81% - 99%	100%	Grand Total
Ej				2		14	16
Em			7	3	7	18	35
En	8	11	16	15	18	29	97
<b>Grand Total</b>	<b>8</b>	<b>11</b>	<b>23</b>	<b>20</b>	<b>25</b>	<b>61</b>	<b>148</b>

Table 5. Degree of rounding present on the artefacts in layers En, Em and Ej.

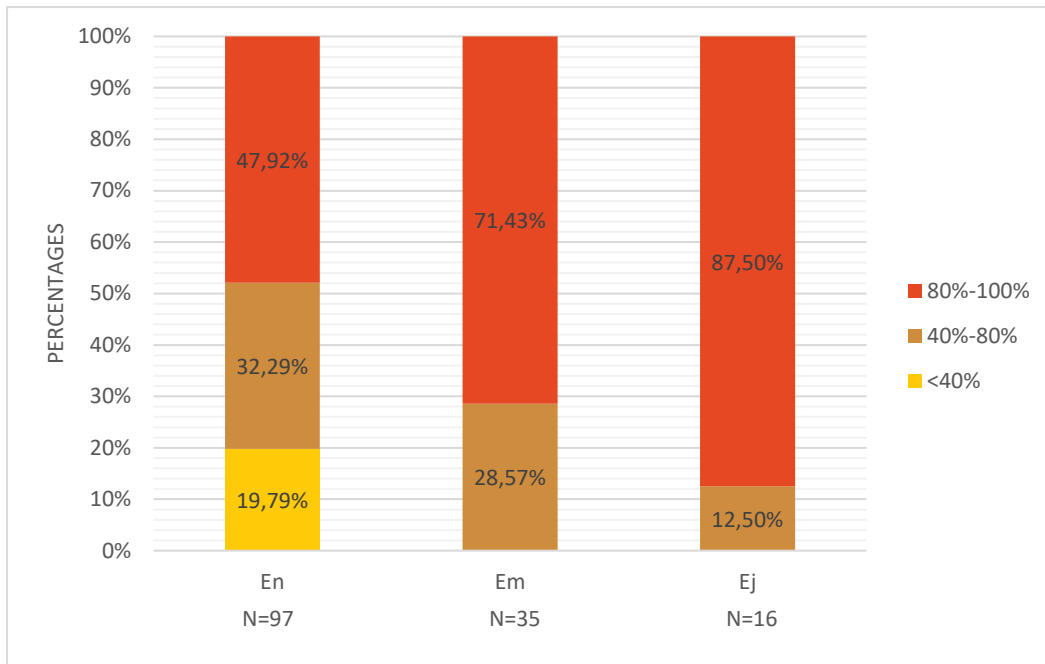

Figure 29. The percentage of CP points' lateral edge affected by damage for layer En, Em and Ej

### 5.10 Edge angle analysis

The edge angle in degrees has been calculated to numbers with two decimal precision. These have been grouped in small classes to give a broad overview of which edge angles degrees are the most prevalent. In this case it can be noted that in layer En and layer Em the edge angles that are the most common are between 31-40 degrees, followed by 41-50 degrees. In layer Ej the degrees of edge angle mainly found is that of 31-40 degrees, secondly 51-60 degrees. Considering the three layers together it can be stated that most artefacts have an edge angle which is between 30 and 60 degrees (84,46%). A very thin edge angle, between 11-20 degrees, is not very well represented in the assemblage (2,70%), and only appears in layer En. Furthermore, a thick edge angle is also very rare: there are only three examples of artefacts that have an edge angle above 60 degrees (2,03%). The average degree of edge angle found in layer En is 38,45 degrees, with a standard deviation of 9,42 degrees. In layer Em this number is 41,69 degrees with a standard deviation of 9,34 degrees. Finally in layer Ej an average edge angle is found of 49,27 degrees and standard deviation of 11,88 degrees. An increase becomes obvious in which the steepness of the edge angle decreases when moving from layer En to the overlying layers. The average edge angle in degrees of all the artefacts throughout the three layers is 40,39 degrees, with a standard deviation of 10,31 degrees.

Edge angle Layers	Degrees							Grand Total
	11-20	21-30	31-40	41-50	51-60	61-70	71-80	
Ej		1	2	6	4	2	1	16
Em		3	14	10	8			35
En	4	12	36	35	10			97
<b>Grand Total</b>	<b>4</b>	<b>16</b>	<b>52</b>	<b>51</b>	<b>22</b>	<b>2</b>	<b>1</b>	<b>148</b>

Table 5. Edge angle of CP points in degrees throughout layers En, Em and Ej

Edge angle Layers	Degrees							Grand Total
	11-20	21-30	31-40	41-50	51-60	61-70	71-80	
Ej	0,00%	6,25%	12,50%	37,50%	25,00%	12,50%	6,25%	100,00%
Em	0,00%	8,57%	40,00%	28,57%	22,86%	0,00%	0,00%	100,00%
En	4,12%	12,37%	37,11%	36,08%	10,31%	0,00%	0,00%	100,00%
<b>Grand Total</b>	<b>2,70%</b>	<b>10,81%</b>	<b>35,14%</b>	<b>34,46%</b>	<b>14,86%</b>	<b>1,35%</b>	<b>0,68%</b>	<b>100,00%</b>

Table 6. Edge angles of CP points in degrees in percentages throughout layers En, Em and Ej.

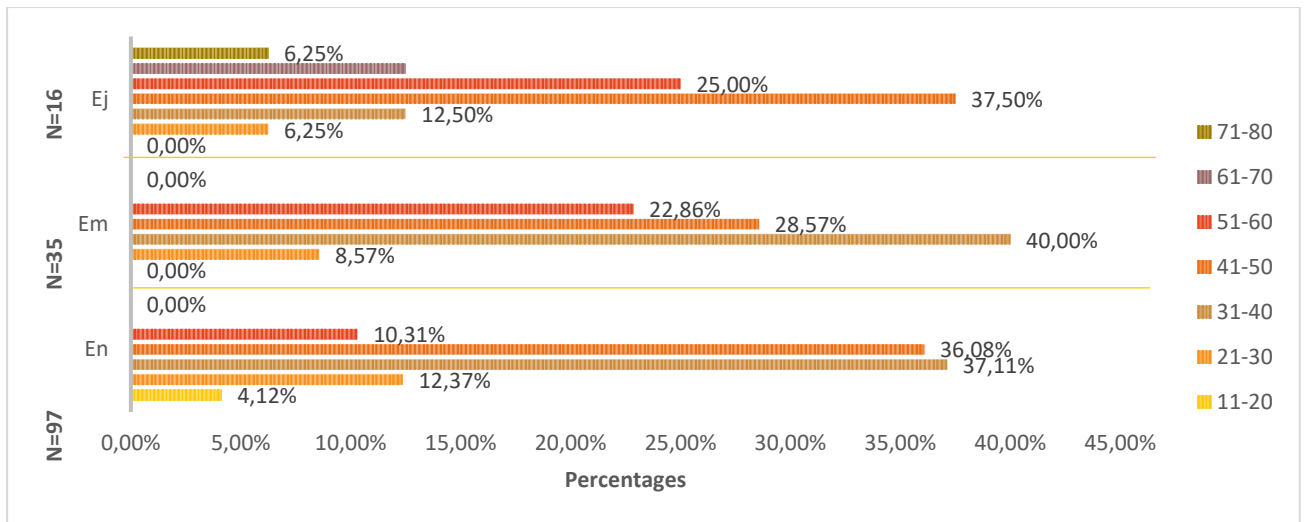

Figure 30. Edge angle in degrees of CP points in percentages per layer.

## 5.10 Steepest affected angle

The steepest affected angle gives important information about the edge angle, and the original steepness a fragmented artefact may have had. Differing from the former edge angle analysis, this attribute is only measured at the steepest point on the edge of the artefact. Analysing the three different layers we find a decrease of artefacts with their steepest affected angle at 0-30 degrees moving from layer En (61,86%), to Em (42,86%) and Ej (31,25%). While the 0-30 degrees decreases, subsequently there is an increase in the artefacts that have their steepest affected angle at 30-60 degrees, with layer Ej being the only layer with the presence of an artefact that has their steepest affected angle at 60-90 degrees.

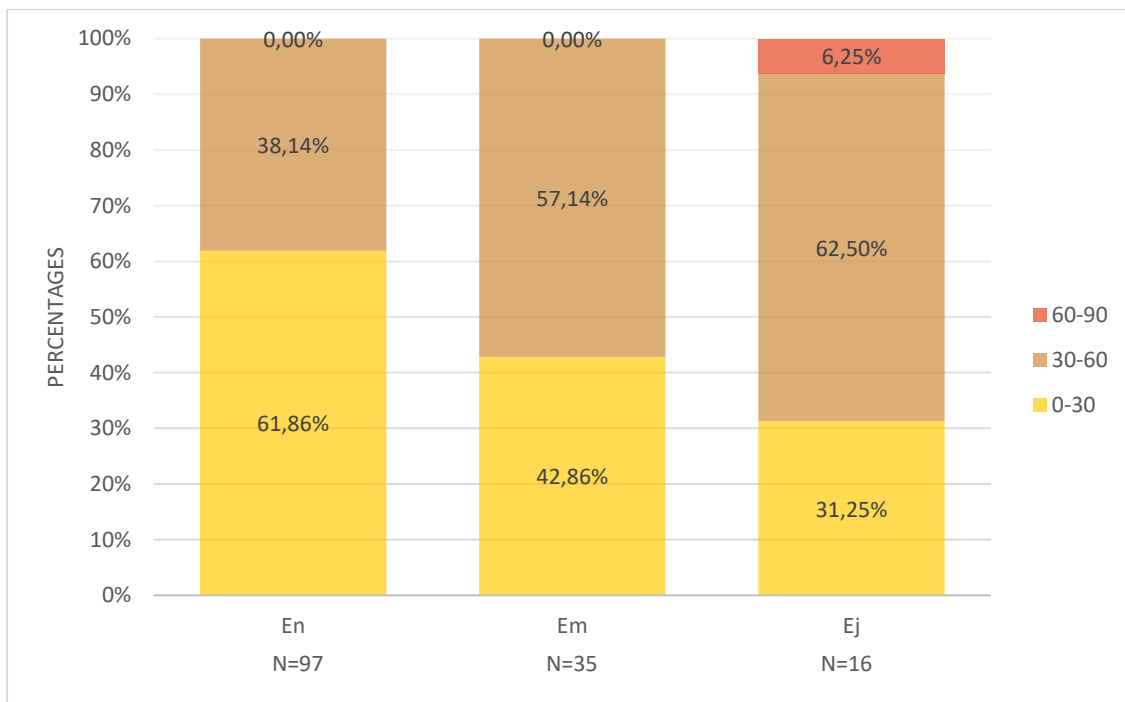

Figure 31. Percentages of steepest affected angle present in layers En, Em and Ej.

When considering the results it becomes clear that layer Ej distinguishes itself from the underlying layers, whereas there is a less significant damage obvious between layers En and Em. Layer En has more of the ‘Invasive’ type damage compared to layer Em. Layer Em however, has a higher percentage of lateral edge affected, higher amount of removals and less steep edges. In most attributes the difference in damage between these two layers is too insignificant to be noteworthy. Layer Ej does show significantly more damage than either of these two layers. The results, and their implications, will be reviewed more thoroughly in the discussion.

## 6. Discussion

### 6.1 Comparing the layers

When considering the data and comparing the layers to each other it becomes clear that layer En and Em are less affected and more similar compared to layer Ej, which is much more damaged. Layers En and Em have similar degrees of edge angles and both have 'Microfracture' as most common damage type, followed by 'Marginal'. In comparison, layer En has the lowest percentage of edge affected (19,8% <40 percent affected), least amount of removals (73,2% <5) and its artefacts have the steepest angles (61,9% 0-30 degrees). On the other hand the CP points from layer Em have less artefacts damaged by the 'Invasive' type. Layer En has ca. 20% more pieces displaying 'Invasive' damage, whereas layer Em has ca. 10% more pieces with the 'Medium' damage type. Layer Em also has a larger number of the 'Marginal' type edge damage. There are also attributes in which these two layers show very similar degrees. For example, layer En only has 5% more complete artefacts, and 5% less artefacts damaged on both faces. Furthermore, the calculated average edge angle is very similar to each other. The data indicates that in most cases layer Em is more heavily damaged, but in some cases layer En appears more damaged, especially in the larger presence of the 'Invasive' damage type. The location and degree of invasiveness of the CP points found in layer En mirrors the location and invasiveness found on the CP points of layer Ej.

The amount of damage found in layer Ej sets it apart from the underlying layers. Only 16 CP points have yielded from this layer, with a very low presence of complete artefacts (N=2). The 'Invasive' type edge damage is the most common, followed by the 'Medium' type. The CP points from layer Ej also have the highest amount of removals, with almost 70% of the artefacts having between 6 to 20+ removals. Furthermore, almost 90% of the pieces have a lateral edge that is affected for 80 to 100% by damage, with no pieces having lateral edge damage less than 40%. When considering the edge angle it is interesting to see that this layer represents the only pieces with an edge angle higher than 60 degrees. Since the thinner edges are the most fragile they are the first to break. This could indicate, since edge angles over 60 degrees are absent in layers En and Em, that these artefacts from layer Ej were more exposed to movement, leading to the removal of the thinner edges. These attributes, together with the high amount of damage on both faces (over 60%) suggests the exposure of the artefacts to an elevated degree of contact with, and movement within, the surrounding matrix.

The degree of edge angle, surrounding substrate and raw material have been suggested as being highly influential on the degree of edge damage present on an artefact (McPherron et al., 2014, pp. 70-82). All artefacts are made up of the same raw material, namely flint. Flint is quite a stiff material, McPherron et al. (2014, p. 76) found that flint is more likely to be damaged, compared to hornfels, due to a lower edge toughness (higher brittleness). This means flint is very likely to become damaged in the archaeological record. The higher the degree of an edge angle, the more fragile and the more



prone to damage it becomes. The points with the highest edge angles are found in layer En, which could indicate a lower exposure to movement which left the thin edges intact. The opposite can be said for the artefacts in layer Ej. As for the substrate: the coarser it is, the higher the presence of damage. The best soil condition for the formation of ice lenses consists of easily permeable, and coarse grained, sediment . (Burroni et al. 2002, p. 1280). Layer En and Em are characterised by a silty sand matrix and layer Ej has a more silty matrix (Soressi et al., 2023, pp. 98-100). The composition of the soil found in layers En and Em are perfect for the vertical upheaval, and damaging, of artefacts. For trampling it counts that the damage will increase with less penetrable substrates and damage rates are higher where artefacts are in high density (McBrearty et al., 1998, p. 110). The high density of artefacts present in layer En could explain the high level of the 'Invasive' damage type, as compared to layer Em.

To summarise, the lithic assemblage from layer En appears the most complete and the lithic assemblage from layer Ej appears the most fragmented. This layer has the artefacts with the highest degree of edge damage, with the largest percentage of lateral edge affected and with the most invasive damage present on its artefacts. The differences in edge damage between layer En and Em are however relatively small.

## **6.2 The hypotheses**

The layers En, Em and Ej have all been regarded as sequential layers representing separate occupations of makers of the Châtelperronian lithic industry. In this scenario, the lithic assemblages of the three layers have all been deposited at separate intervals and damaged soon after deposition. The severity of damage in layer Ej could be explained by the interaction of the artefacts with the high number of limestone clast inclusions.

However, the above presented results suggest these occupations might not separate. The differences in the degree of damage, and severity of artefacts found in layer Ej, indicate that the artefacts were actually deposited at one moment, or two moments, in time and space, but got redistributed over separate layers and damaged and dispersed due to the formation of ice lenses and vertical upheaval. One scenario suggests that the artefacts from layer Ej, which are the most severely damaged, were not originally deposited in that layer, but are the result of frost heave from layer Em. By extensive interaction with the poorly sorted sediment of layer Ej the artefacts became heavily damaged. Furthermore, the redistribution of the artefacts could also imply that the artefacts found in layer Em and Ej are both the result of upward frost heaving, indicating that all CP points were deposited in layer En but got displaced over three separately interpreted layers. These two scenarios are explained in more detail below.

### 6.2.1 Mixing and dispersal

The least amount of artefacts are produced by layer E<sub>j</sub>, with the ones that do yield from this layer all being severely damaged and found at the base where it meets with layer E<sub>m</sub>. Recent studies of the layer have described the presence of an abundance of angular to sub-rounded tabular limestone clasts of varying sizes. The most dominant size are those of 5 to 10 cm in diameter, but large clasts reaching 20 to 25 cm in diameter are also common (Soressi et al., 2023, p. 100). These deposits are typical of a periglacial climate, and can be defined by an accumulation of debris through disintegration, poor sorting and coarse bedding as the result of frost action (Karkanas & Goldberg, 2019, p. 81). Rowlett & Robbins (1982, p. 73) have noted on the commonness for the separation of occupational levels in rock shelter sites in the Upper and Middle Palaeolithic of southwestern France by sterile zones of poorly sorted and coarse bedded deposits. These sterile zones can end up including a couple of artefacts due to taphonomic processes induced by the periglacial climate. The composition of layer E<sub>j</sub> fits this description and suggests that it was formed post-occupationally through the accumulation of large limestone clasts by the effects of frost action in the cave (Karkanas & Goldberg, 2019, p. 81) and was meant to be sterile (Rowlett & Robbins, 1982, p. 73). The original excavators already noted on the high percentage of frost-prone plates present on the clasts (Lévêque & Miskovsky, 1983, p. 375), and the recent excavators have documented cryo-expulsion features within this layer, which shows the strong influence of frost action on the site formation of Quinçay (Soressi et al., 2023, p. 100).

Buried artefacts in soils affected by cyclic freezing and thawing, have been experimentally shown to periodically move upward (Johnson & Hansen, 1974, p. 84). The more an artefact is exposed to movement, while being in constant contact with the surrounding matrix, the more damaged it will become (Viklander, 1998, p. 145). Interestingly, Johnson & Hansen (1974, p. 85) have also indicated that the more shallow an artefact has been buried, the greater its upward movement will be. With the artefacts that are buried the deepest moving the least, respectively. It is important to be wary when comparing their experiment to compact Pleistocene sediment which has been subject to thousands of years of freeze-thaw cycles. However, it still shines an interesting light on the degree of redistribution and accumulation of damage that has taken place in SAG1 before the thousands of years of frost action.

One hypothetical scenario that aims to explain the degree of damage and distribution of the CP points is that all the artefacts in SAG1 have originated in one layer: Layer E<sub>n</sub>. Recent studies of layer E<sub>n</sub> have taken note of the developed frost-induced microstructures in the sediment, which indicate frost action. The artefacts retrieved from this layer represent edge damage caused by the effects of cryoturbation. However, compared to the other layers, the artefacts from layer E<sub>n</sub> show the least amount of edge affected by damage and least amount of removals (See chapter 5. Results). With this,

it could be suggested that the artefacts now distributed throughout SAG1 were initially all deposited around the same time and space in layer En, but got displaced by the formation of ice lenses and vertical upheaving, which disturbed the original distribution and caused damage to the artefacts. The artefacts deposited close to, or directly on, the surface of layer En could have moved periodically upward into layer Em, considering that the shallower an artefact is buried the more prone to movement towards the surface it becomes by cryoturbation (Johnson & Hansen, 1974, p. 85). This explains the small number of artefacts, larger edge affected and more removals found in layer Em in comparison to layer En. Due to their shallow position in the coarse grained and saturated matrix, these artefacts were again exposed to cryoturbation. After many years of freeze-thaw cycles the artefacts became randomly distributed throughout SAG1. Recurring freeze-thaw cycles made for multiple occasions of vertical upheaval and dispersal of the artefacts from layer En into layer Em and Ej. The ones exposed the longest finishing in layer Ej, which subsequently were also damaged the heaviest due to the constant interaction with and movement through the substratum. The similarity in edge damage found in layers En and Em, compared to layer Ej, is due to the limited distance and less inclusions of large stones or limestone clasts exceeding 10 cm in between layer En and Em (Fig. 7 in chapter 3). Evidence of frost action has been described in the recent interpretations of layer Em, with a presence of frequent vertically oriented subangular to subrounded limestone clasts up to 10 cm in diameter, with their orientation most likely related to frost heave (Soressi et al., 2023, p. 99). In this scenario, all artefacts had the same origin and were redistributed from layer En

Nevertheless, the distribution of the artefacts in layer Em is not very random, which would be expected (Lenoble et al. 2008, pp. 99-110). The base and upper 5 cm of layer Em yield less stones and artefacts, compared to the middle part of the layer in which an abundance of faunal and lithic artefacts are found (Soressi et al., 2023, p. 99). Also, a steady increase in damage would be expected if all artefacts originated from the same layer, however this is not observed. The non-random distribution, as well as the small differences in damage between layers En and Em, suggest that there may not have been movement from single occupational layer En, into Em and Ej.

A different theory can be posed which regards the deposition of the artefacts found in layers En and Em at separate occupational intervals. In this scenario layer En and Em are acknowledged as being separately deposited representatives of the Châtelperronian industry, as is suggested by their small difference in degree of damage. Due to the formation of ice lenses the artefacts that were originally deposited in layer Em were heaved upwards, and were displaced onto the surface, or into the overlying layer Ej, if it had already been formed that is. During this upwards movement the artefacts would become increasingly damaged due to the constant exposure to the surrounding poorly sorted, coarse-bedded, saturated substrate with large limestone clast inclusions (Burrioni et al. 2002, p. 1280). The low presence of artefacts in the top part of layer Em (Soressi et al., 2023, p. 99) could be explained by their original shallow location in the soil before being exposed to cryoturbation, as

indicated by Johnson & Hansen (1974, p. 85), which caused them to be moved upwards the most into layer Ej. This factor, considered together with the poorly sorted, coarse bedded matrix the artefacts are exposed to in layer Ej, would explain the severity of the damage found in this layer. It would also explain why there is not much difference between layers En and Em. Indicating their deposition not long after each other, relatively. Layer En has the least amount of damage due to being buried the deepest and by having the least amount of large inclusions with which the CP points can interact (See Fig. 7 in chapter 3) (Johnson & Hansen, 1974, p. 84). That the artefacts from this layer show more of the 'Invasive' type damage could be due to more invasive trampling post-depositionally, compared to layer Em. That the artefacts from layer Em has more of its lateral edge affected and more removals is due to a higher exposure, compared to layer En, to the effects of cryoturbation. The periodic upheaval of the soil and artefacts of the artefacts caused the CP points originating in layer Em to be dispersed to layer Ej. The invasiveness of damage and small presence of CP points in layer Ej could also be due to other processes besides frost induced ones. Due to cryoturbation the artefacts from layer Em could have been pushed to the surface, where they could have been exposed to severe trampling. Cultural processes, like recycling, could also be contemplated, but this needs to be researched further.

### **6.2.2 Separate occupations**

When regarding the amount of damage present on all artefacts throughout the three layers, and considering the effect frost action can have on the preservation and distribution of lithic assemblages, it becomes hard to deem any of the artefacts to be in their original context. The differences in the degrees of damage, especially when comparing layers En and Em to layer Ej, suggest that they may not all represent separate occupations of makers of the Châtelperronian industry, as was originally interpreted (Lévêque & Miskovsky, 1983, p. 375; Roussel et al., 2016, p. 14; Soressi et al., 2023, p. 15). A concentration of artefacts and their location in the archaeological matrix cannot be seen as clearcut evidence for lack of site distortion. Lenoble et al (2008, p. 108) argue that even though a site might present itself as easily understood, or not affected by perturbation, another interpretation could still become available with closer inspection. This indicates that none of the assemblages found in the three layers are in the location of their original deposition, and have all been exposed to site formation processes.

## 7.0 Conclusion

This thesis has aimed at making a quantification of the degree of edge damage found on the CP points yielding from three separate layers at the front of the cave at Quinçay. The most common edge damage found in layers En and Em is the ‘Marginal’ and ‘Microfracture’ types. However, in layer Ej the most common are the ‘Invasive’ and ‘Medium’ damage types. Considering the degree of damage it becomes clear that layer Ej shows a higher severity in the degree of damage compared to the underlying layers. This difference is less notable between layers En and Em. Layer En has a higher percentage of the ‘Invasive’ type damage and bigger removals, but layer Em has a larger percentage of the lateral edge affected and more removals overall. Layer En shows the least amount of removals, least amount of lateral edge affected and has the steepest angles (Research Question 1). Overall this layer is characterised by being the most complete. However, it is difficult to conclude that this layer is also the least damaged since the observations do not differ much from those made on layer Em. Furthermore, the ‘Invasive’ type damage and is more common in layer En than in layer Em. Layer Em does show a higher degree of edge damage more commonly, with an increase in percentage of lateral edge affected, steepest angle affected, amount of removals and fragmentation when moving from layers En, to Em and Ej. Nonetheless, the damage present on the artefacts in layer Ej is the most severe compared to the damage in the underlying layers (Research Question 2). The damage present on all artefacts has been mainly the cause of frost action in the soil. Solifluction and cryoturbation are common in cave systems in which the layers were formed during a periglacial climate (Karkanas & Goldberg, 2019, p. 81). The action of frost heaving has influenced the preservation and distribution of the lithic assemblage present throughout the layers, with layer Ej being affected the most due to its proximity to the surface (Johnson & Hansen, 1974, p. 85) (Research Question 3).

Two possible scenarios have been proposed, challenging the notion of the presence of an occupational sequence of makers of the Châtelperronian techno-complex. Different scenarios are discussed for the difference in damage, especially considering the severity of damage present in layer Ej. Further research should be aimed at attempting to rule out, or test, the likelihood for the occurrence of (one of) the scenarios. For this clear radiocarbon and Optically Stimulated Luminescence (OSL) dates yielding from these three layers could prove to be useful. With absolute dates a better understanding could be gained on the chronology and formation processes of the different layers. OSL and radiocarbon samples have been taken before, but nothing conclusive has been published (Soressi et al., 2023, p. 66). Furthermore, it would be valuable to do quantitative microscopic analysis and a documentation in QGIS of the assemblage to gain a more detailed insight into which other processes could have caused the damage on the CP points. Using this method it could become clear why layer En has a high degree of the ‘Invasive’ type damage, compared to layer Em, for example. It is important to also consider the effects that trampling could have had on the assemblages, or the degree of rounding on the lateral edges, which this research did not focus on much. The presence of these

processes can become obvious by conducting a microscopic analysis. Finding out in which ways layers En and Em are different from each other will also be very useful for understanding the formation of the layers. Studying the artefact density in the layers and the density of inclusions that increase damage will be interesting to gain knowledge on. Future research should be focused on answering the new questions this thesis has raised, and should aim at getting a step closer to comprehending what exactly happened in the soil during the site formation of Quinçay during the last thirty thousand years or so.

## 8. Abstract

The Châtelperronian is a technological industry dating to the crucial time period in which Neanderthal populations got replaced by early modern human populations during the Middle to the Upper Palaeolithic transition. The industry has been subject to much debate due to the uncertainty regarding its makers. La-Grande-Roche-de-la-Plématrie, Quinçay, France, is an important site because of the rare preservation of the Châtelperronian throughout multiple layers. These deposits have been protected for ca. 25,000 years due to the collapse of large limestone slabs, which has stopped the layers from mixing with later occupations. The Châtelperronian points (CP points) yielding from these layers show significant edge damage, which questions whether they can be considered as *in situ* or whether the assemblage has been redistributed by site formation processes. This thesis aims at gaining a better insight into whether the Châtelperronian points have been deposited at separate occupational periods, or whether they have been subjected to movement by site formation processes disturbing the original position of deposition. Quantitative analysis is conducted which describes and documents the degree of edge damage present on the artefacts from three layers in the front of the cave.

## 9. Bibliography

- Alhusban, Z., & Valyrakis, M. (2021). Assessing and Modelling the Interactions of Instrumented Particles with Bed Surface at Low Transport Conditions. *Applied Sciences*, 11(16), Article 16. <https://doi.org/10.3390/app11167306>
- Banks, W. E., d'Errico, F., & Zilhão, J. (2013). Revisiting the chronology of the Proto-Aurignacian and the Early Aurignacian in Europe: A reply to Higham et al.'s comments on Banks et al. (2013). *Journal of Human Evolution*, 65(6), 810–817. <https://doi.org/10.1016/j.jhevol.2013.08.004>
- Barshay-Szmidt, C., Normand, C., Flas, D., & Soulier, M.-C. (2018). Radiocarbon dating the Aurignacian sequence at Isturitz (France): Implications for the timing and development of the Protoaurignacian and Early Aurignacian in western Europe. *Journal of Archaeological Science: Reports*, 17, 809–838. <https://doi.org/10.1016/j.jasrep.2017.09.003>
- Bocek, B. (1986). Rodent Ecology and Burrowing Behavior: Predicted Effects on Archaeological Site Formation. *American Antiquity*, 51(3), 589–603. <https://doi.org/10.2307/281754>
- Bustos-Pérez, G., & Ollé, A. (2023). The quantification of surface abrasion on flint stone tools. *Archaeometry*, 66(2), 247–265. <https://doi.org/10.1111/arcm.12913>
- Burroni, D., Donahue, R. E., Pollard, A. M., & Mussi, M. (2002). The Surface Alteration Features of Flint Artefacts as a Record of Environmental Processes. *Journal Of Archaeological Science*, 29(11), 1277–1287. <https://doi.org/10.1006/jasc.2001.0771>
- Dibble, H. L., & Bernard, M. C. (1980). A Comparative Study of Basic Edge Angle Measurement Techniques. *American Antiquity*, 45(4), 857–865. <https://doi.org/10.2307/280156>
- Dibble, H. L., McPherron, S. P., Chase, P. G., Farrand, W. R., & Debénath, A. (2006). Taphonomy and the concept of Paleolithic Cultures : the case of the Tayacian from Fontéchevade (Charente, France). *Palaeoanthropology Society*, 1–21. <http://pubman.mpdl.mpg.de/pubman/item/escidoc:1555177>
- Djakovic, I. (2021). *Squeezing Blood From Stone? The Châtelperronian laminar technology from Quinçay, France and the (initial) Upper Palaeolithic phenomenon*. [Master thesis]. Leiden Universiteit.
- Djakovic, I., Key, A., & Soressi, M. (2022). Optimal linear estimation models predict 1400–2900 years of overlap between Homo sapiens and Neandertals prior to their disappearance from France and northern Spain. *Scientific Reports*, 12(1), 15000. <https://doi.org/10.1038/s41598-022-19162-z>
- Fewlass, H., Talamo, S., Wacker, L., Kromer, B., Tuna, T., Fagault, Y., Bard, E., McPherron, S. P., Aldeias, V., Maria, R., Martisius, N. L., Paskulin, L., Rezek, Z., Sinet-Mathiot, V., Sirakova, S., Smith, G. M., Spasov, R., Welker, F., Sirakov, N., ... Hublin, J.-J. (2020). A 14C chronology for the



Middle to Upper Palaeolithic transition at Bacho Kiro Cave, Bulgaria. *Nature Ecology & Evolution*, 4(6), 794–801. <https://doi.org/10.1038/s41559-020-1136-3>

Gifford, D. P. (1981). Taphonomy and Paleocology: A Critical Review of Archaeology's Sister Disciplines. *Advances in Archaeological Method and Theory*, 4, 365–438.

Gifford-Gonzalez, D. P., Damrosch, D. B., Damrosch, D. R., Pryor, J., & Thunen, R. L. (1985). The Third Dimension in Site Structure: An Experiment in Trampling and Vertical Dispersal. *American Antiquity*, 50(4), 803–818. <https://doi.org/10.2307/280169>

Gravina, B., Bachellerie, F., Caux, S., Discamps, E., Faivre, J.-P., Galland, A., Michel, A., Teyssandier, N., & Bordes, J.-G. (2018). No Reliable Evidence for a Neanderthal-Châtelperronian Association at La Roche-à-Pierrot, Saint-Césaire. *Scientific Reports*, 8(1), 15134. <https://doi.org/10.1038/s41598-018-33084-9>

Green, R. E., Krause, J., Briggs, A. W., Maricic, T., Stenzel, U., Kircher, M., Patterson, N., Li, H., Zhai, W., Fritz, M. H.-Y., Hansen, N. F., Durand, E. Y., Malaspinas, A.-S., Jensen, J. D., Marques-Bonet, T., Alkan, C., Prüfer, K., Meyer, M., Burbano, H. A., ... Pääbo, S. (2010). A Draft Sequence of the Neandertal Genome. *Science*, 328(5979), 710–722. <https://doi.org/10.1126/science.1188021>

Harris, C., Davies, M. C. R., & Coutard, J. (1997). Rates and processes of periglacial solifluction: an experimental approach. *Earth Surface Processes And Landforms*, 22(9), 849–868. [https://doi.org/10.1002/\(sici\)1096-9837\(199709\)22:9](https://doi.org/10.1002/(sici)1096-9837(199709)22:9)

Higham, T., Jacobi, R., Julien, M., David, F., Basell, L., Wood, R., Davies, W., & Ramsey, C. B. (2010). Chronology of the Grotte du Renne (France) and implications for the context of ornaments and human remains within the Châtelperronian. *Proceedings Of The National Academy Of Sciences Of The United States Of America*, 107(47), 20234–20239. <https://doi.org/10.1073/pnas.1007963107>

Hublin, J.-J., Spoor, F., Braun, M., Zonneveld, F., & Condemi, S. (1996). A late Neanderthal associated with Upper Palaeolithic artefacts. *Nature*, 381(6579), 224–226. <https://doi.org/10.1038/381224a0>

Hublin, J.-J., Talamo, S., Julien, M., David, F., Connet, N., Bodu, P., Vandermeersch, B., & Richards, M. P. (2012). Radiocarbon dates from the Grotte du Renne and Saint-Césaire support a Neandertal origin for the Châtelperronian. *Proceedings of the National Academy of Sciences*, 109(46), 18743–18748. <https://doi.org/10.1073/pnas.1212924109>

Hublin, J.-J. (2015). The modern human colonization of western Eurasia: When and where? *Quaternary Science Reviews*, 118, 194–210. <https://doi.org/10.1016/j.quascirev.2014.08.011>

Hublin, J.-J., Sirakov, N., Aldeias, V., Bailey, S., Bard, E., Delvigne, V., Endarova, E., Fagault, Y., Fewlass, H., Hajdinjak, M., Kromer, B., Krumov, I., Marreiros, J., Martisius, N. L., Paskulin, L., Sinet-Mathiot, V., Meyer, M., Pääbo, S., Popov, V., ... Tsanova, T. (2020). Initial Upper Palaeolithic

Homo sapiens from Bacho Kiro Cave, Bulgaria. *Nature*, 581(7808), 299–302.

<https://doi.org/10.1038/s41586-020-2259-z>

Karkanas, P., & Goldberg, P. (2019). *Reconstructing Archaeological Sites: Understanding the Geoarchaeological Matrix*.

Johnson, D. L., & Hansen, K. L. (1974). The Effects of Frost-Heaving on Objects in Soils. *Plains Anthropologist*, 19(64), 81–98.

Lenoble, A., Bertrán, P., & Lacrampe, F. (2008). Solifluction-induced modifications of archaeological levels: simulation based on experimental data from a modern periglacial slope and application to French Palaeolithic sites. *Journal Of Archaeological Science*, 35(1), 99–110.

<https://doi.org/10.1016/j.jas.2007.02.011>

Lévêque, F., Miskovski, J.C., 1983. Le Castelperronien dans son environnement géologique. Essai de synthèse à partir de l'étude lithostratigraphique du remplissage de la grotte de la Grande Roche de la Plématrie (Quinçay, Vienne) et d'autres dépôts actuellement mis au jour. *L'Anthropologie*. 87, 369–391.

McBrearty, S., Bishop, L. C., Plummer, T. W., Dewar, R. E., & Conard, N. J. (1998). Tools Underfoot: Human Trampling as an Agent of Lithic Artifact Edge Modification. *American Antiquity*, 63(1), 108–129. <https://doi.org/10.2307/2694779>

McPherron, S. P., Braun, D. R., Dogandžić, T., Archer, W., Desta, D., & Lin, S. C. (2014b). An experimental assessment of the influences on edge damage to lithic artifacts: a consideration of edge angle, substrate grain size, raw material properties, and exposed face. *Journal of Archaeological Science*, 49, 70–82. <https://doi.org/10.1016/j.jas.2014.04.003>

O'Brien, M. (n.d.). *Cryoturbation effects of upheaving on vertical deposition of lithic artifacts* [M.A., University of Wyoming]. Retrieved 26 April 2024, from

<https://www.proquest.com/docview/304974762/abstract/32CB2CC873C64831PQ/1>

Prüfer, K., Posth, C., Yu, H., Stoessel, A., Spyrou, M. A., Deviese, T., Mattonai, M., Ribechini, E., Higham, T., Velemínský, P., Brůžek, J., & Krause, J. (2021). A genome sequence from a modern human skull over 45,000 years old from Zlatý kůň in Czechia. *Nature Ecology & Evolution*, 5(6), 820–825. <https://doi.org/10.1038/s41559-021-01443-x>

Ruebens, K., McPherron, S. J. P., & Hublin, J.-J. (2015). On the local Mousterian origin of the Châtelperronian: Integrating typo-technological, chronostratigraphic and contextual data. *Journal of Human Evolution*, 86, 55–91. <https://doi.org/10.1016/j.jhevol.2015.06.011>

Roussel, M., Soressi, M., & Hublin, J.-J. (2016). The Châtelperronian conundrum: Blade and bladelet lithic technologies from Quinçay, France. *Journal of Human Evolution*, 95, 13–32.

<https://doi.org/10.1016/j.jhevol.2016.02.003>

- Rowlett, R. M., & Robbins, M. C. (1982). Estimating Original Assemblage Content to Adjust for Post-Depositional Vertical Artifact Movement. *World Archaeology*, 14(1), 73–83.
- Schiffer, M. B. (1972). Archaeological Context and Systemic Context. *American Antiquity*, 37(2), 156–165. <https://doi.org/10.2307/278203>
- Soressi, M., & Roussel, M. (2010). La Grande Roche de la Plématrie à Quinçay (Vienne). L'évolution du Châtelperronien revisitée. In: *Préhistoire Entre Vienne et Charente - Hommes et Sociétés Du Paléolithique*, J. Buisson-Catil & J. Primault (Dir.), Association Des Publications Chauvinoises (Ed.), *Mémoire 38* : 203-219.
- Soressi, M., & Roussel, M. (2014). European Middle to Upper Paleolithic Transitional Industries: Châtelperronian. In C. Smith (Ed.), *Encyclopedia of Global Archaeology* (pp. 2679–2693). Springer. [https://doi.org/10.1007/978-1-4419-0465-2\\_1852](https://doi.org/10.1007/978-1-4419-0465-2_1852)
- Soressi, M., Aldeias, V., Djakovic, I., Murphree, W., & Soullier, M.C., Dandurand, G., Sorensen, A., Kroon, E. (2023). *La Grande Roche de la Plématrie Quinçay (Vienne) Rapport de fouille programmée 2022 Tri-annuelle 1 année 3/3*.
- Tringham, R., Cooper, G. E., Odell, G. H., Voytek, B., & Whitman, A. (1974). Experimentation in the Formation of Edge Damage: A New Approach to Lithic Analysis. *Journal of Field Archaeology*, 1(1–2), 171–196. <https://doi.org/10.1179/jfa.1974.1.1-2.171>
- Turk, J., & Turk, M. (2010). Paleotemperature record in late pleistocene clastic sediments at Divje babe 1 cave (Slovenia). *Journal of Archaeological Science*, 37(12), 3269–3280. <https://doi.org/10.1016/j.jas.2010.07.030>
- Vandermeersch, B. (1984). A propos de la découverte du squelette néandertalien. *Bulletins et Mémoires de la Société d'Anthropologie de Paris*, 1(3), 191–196. <https://doi.org/10.3406/bmsap.1984.3932>
- Van Vliet-Lanoë, B. (1985). Frost effects in soils. In J. Boardman (Ed.), *Soil and Quaternary Landscape Evolution* (pp. 115-156) J. WILEY Publ.
- Van Vliet-Lanoë, B. (1998). Frost and soils: implications for paleosols, paleoclimates and stratigraphy. *Catena*, 34(1–2), 157–183. [https://doi.org/10.1016/s0341-8162\(98\)00087-3](https://doi.org/10.1016/s0341-8162(98)00087-3)
- Viklander, P. (1998). Laboratory study of stone heave in till exposed to freezing and thawing. *Cold Regions Science And Technology*, 27(2), 141–152. [https://doi.org/10.1016/s0165-232x\(98\)00004-4](https://doi.org/10.1016/s0165-232x(98)00004-4)
- Villa, P. (1982). Conjoinable Pieces and Site Formation Processes. *American Antiquity*, 47(2), 276–290. <https://doi.org/10.2307/279901>
- Villa, P., & Soressi, M. (2000). Stone tools in carnivore sites: the case of Bois Roche. *Journal of Anthropological Research*, 56(2), 187–215. <https://doi.org/10.1086/jar.56.2.3631362>